

REV.	ECN. NO.	APPD.
A	BC-14-0026756	L. C. WU

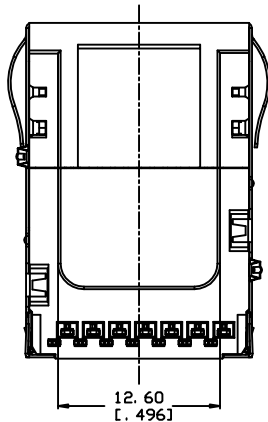

VIEW T

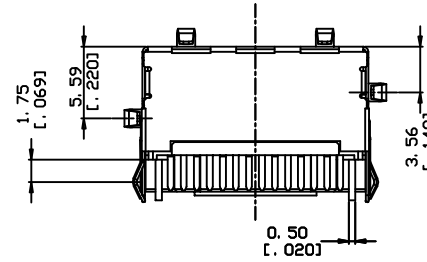
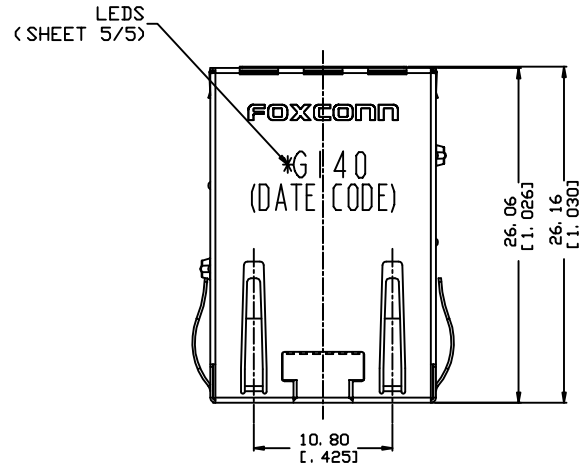

VIEW S

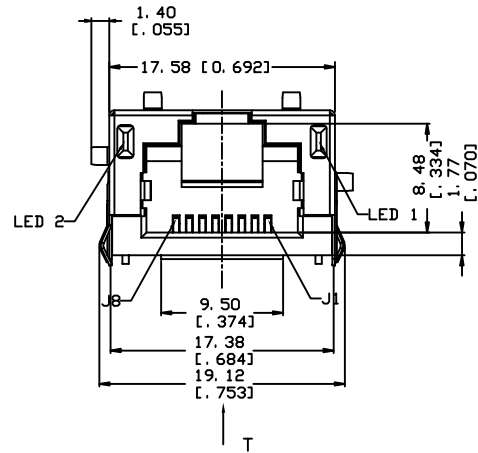
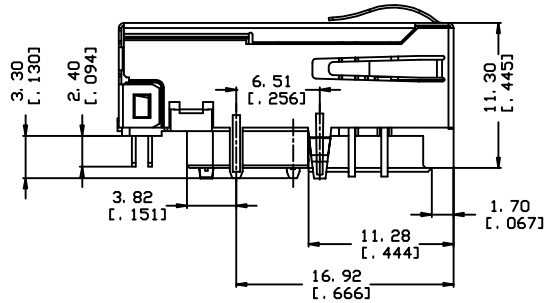

T

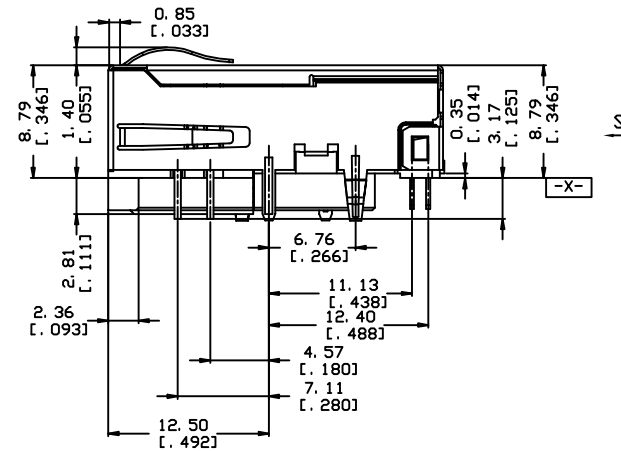

S

NOTES: UNLESS OTHERWISE SPECIFIED

- RJ45 TO BE BASED UPON FCC 68.5.
- RECOMMENDED PCB THICKNESS TO BE 1.57[.062]
- PCB STANDOFF SURFACE TO BE DATUM -X-
- HARMFUL MATERIAL CONTROL COMPLIANT ROHS.
- LASER PRINT MARK:

JFM3811 G140-4F

① *G140

② ***** LEDS+EXTENSION CODE

DATE CODE

X± /	X* ± /	UNITS MM[INCH]	NAME (INTENDED USE) CUSTOMER	FOXCONN FOXCONN INTERCONNECT TECHNOLOGY LIMITED.
. X± 0.30 [0.012]	. X* ± /	MAT' L	PART NO. (INTENDED USE)	
. XX± 0.25 [0.010]	. XX* ± /	FINISH	JFM3811*-G140-*F	CLASS: <input type="checkbox"/> CONFIDENTIAL <input type="checkbox"/> SECRET <input checked="" type="checkbox"/> GENERAL
. XXX± 0.25 [0.010]	. XXX* ± /		Q' TY	APPD: L. C. WU 05/29' 14
THESE DRAWINGS AND SPECIFICATIONS ARE THE PROPERTY OF FOXCONN INTERCONNECT TECHNOLOGY LIMITED, AND SHALL NOT BE REPRODUCED, COPIED OR USED IN ANY MANNER WITHOUT THE PRIOR WRITTEN CONSENT OF FOXCONN INTERCONNECT TECHNOLOGY LIMITED.			CHKD: J. H. HU 05/29' 14	DWG NO. : 305-0000-4768
			DR: D. K. LIU 05/29' 14	SCALE SHEET REV. N/A 1/5 A

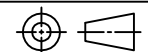

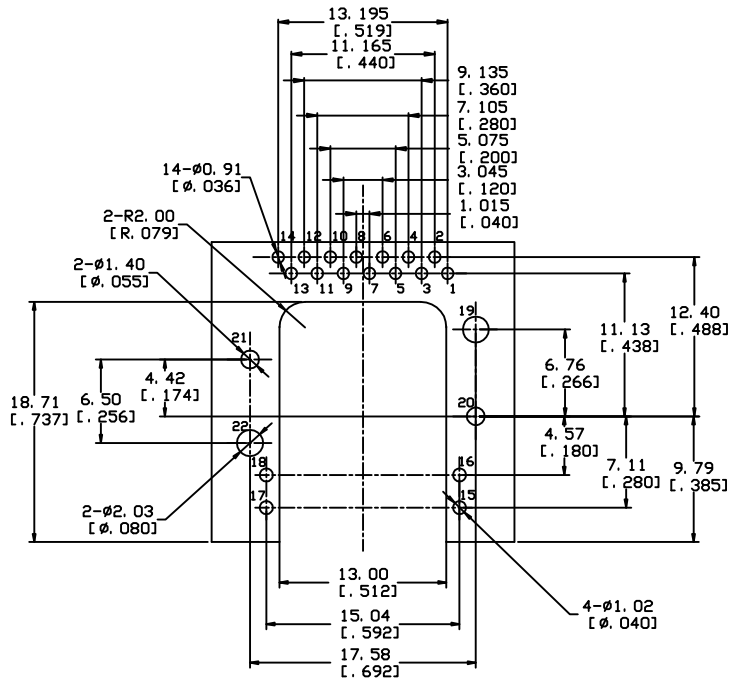

RECOMMENDED PCB FOOTPRINT
TOP VIEW (COMPONENT SIDE)

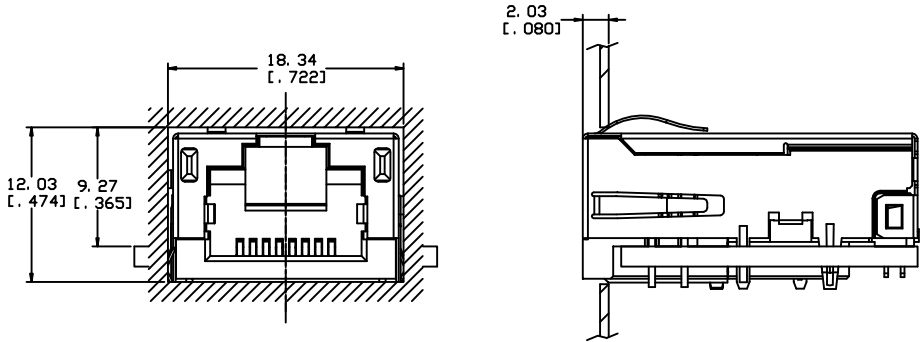

RECOMMENDED PANEL CUTOUT

JFM3811B-G140-*F		
JFM3811A-G140-*F		
JFM3811J-G140-*F		
PART NO.	LED2 (LEFT)	LED1 (RIGHT)

X± /	X* ± /	UNITS MM [INCH]	NAME (INTENDED USE) CUSTOMER	FOXCONN FOXCONN INTERCONNECT TECHNOLOGY LIMITED.
. X±	. X* ± /	MAT' L	PART NO. (INTENDED USE) JFM3811*-G140-*F	CLASS: <input type="checkbox"/> CONFIDENTIAL <input type="checkbox"/> SECRET <input checked="" type="checkbox"/> GENERAL
. XX± [0.05 [0.002]	. XX* ± /	FINISH	APPD: L. C. WU 05/29' 14	TITLE: RJ45 , 1X1, T/U, T/H, 10/1000
. XXX±	. XXX* ± /	Q' TY	CHKD: J. H. HU 05/29' 14	DWG NO. : 305-0000-4768
THESE DRAWINGS AND SPECIFICATIONS ARE THE PROPERTY OF FOXCONN INTERCONNECT TECHNOLOGY LIMITED, AND SHALL NOT BE REPRODUCED, COPIED OR USED IN ANY MANNER WITHOUT THE PRIOR WRITTEN CONSENT OF FOXCONN INTERCONNECT TECHNOLOGY LIMITED.			DR: D. K. LIU 05/29' 14	SCALE SHEET REV. N/A 2/5 A

NOTES : UNLESS OTHERWISE SPECIFIED

- 6. ALL SHIELDING PINS TO BE CONNECTED TO SHELL GROUNDING.
- 7. ELECTRICAL SPECIFICATIONS @ 25C:

INSERTION LOSS -1.0dB MAX. @ 1-100MHz;
 RETURN LOSS -16dB Min. @ 1-40MHz;
 -10dB Min. @ 40-100MHz;

 CMRR -30dB MIN. @ 1-100MHz;
 DCMR -30dB MIN. @ 1-100MHz;
 CROSSTALK -27.1+16.8Log(f/100)dB MIN. @ 1-100MHz;
 HI-POT<ISOLATION VOLTAGE> 1500VAC
 TURNS RATIO:
 PRIMARY <PHY> VS SECONDARY <CABLE> 1CT : 1CT ±3%
 PRIMARY INDUCTANCE<QCL>: 350 uH MIN. @100KHz/100mVRMS, 8mA DC BIAS

SCHMATIC



X± /	X* ± /	UNITS dB	NAME< INTENDED USE> CUSTOMER	FOXCONN FOXCONN INTERCONNECT TECHNOLOGY LIMITED.		
. X± /	. X* ± /	MAT' L	PART NO. < INTENDED USE>	CLASS: <input type="checkbox"/> CONFIDENTIAL <input type="checkbox"/> SECRET <input checked="" type="checkbox"/> GENERAL		
. XX± /	. XX* ± /	FINISH	JFM3811*-G140-*F	TITLE: RJ45 , 1X1, T/U, T/H, 10/1000		
. XXX± /	. XXX* ± /		APPD: L. C. WU 05/29' 14	DWG NO. : 305-0000-4768		
THESE DRAWINGS AND SPECIFICATIONS ARE THE PROPERTY OF FOXCONN INTERCONNECT TECHNOLOGY LIMITED, AND SHALL NOT BE REPRODUCED, COPIED OR USED IN ANY MANNER WITHOUT THE PRIOR WRITTEN CONSENT OF FOXCONN INTERCONNECT TECHNOLOGY LIMITED.			Q' TY	CHKD: J. H. HU 05/29' 14		SCALE
			DR: D. K. LIU 05/29' 14			SHEET

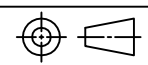

N/A	3/5	A
-----	-----	---

SPECIFICATIONS:

1. ELECTRICAL:

- 1.1 CURRENT RATING: 1.5 AMPERES MAX.
- 1.2 CONTACT RESISTANCE: 60 mΩ MAX INITIAL.

2. MECHANICAL:

- 2.1 MATING FORCE: 4.5 LBS MAX. WITH LATCH DEPRESSED AT AN ADVANTAGEDOUS ANGLE.
- 2.2 DURABILITY (MATING/UNMATING): 5000 CYCLES
- 2.3 OPERATING TEMPERATURE: -40°C TO +85°C
- 2.4 FLAMMABILITY: UL 94V-0

3. LED'S CHARACTERISTICS:

FORWARD VOLTAGE IF=20mA GREEN 1.80~2.60V
 DOMINANT WAVELENGTH IF=20mA GREEN 562~568nm

FORWARD VOLTAGE IF=20mA YELLOW 1.80~2.40V
 DOMINANT WAVELENGTH IF=20mA YELLOW 575~581nm

FORWARD VOLTAGE IF=20mA ORANGE 1.80~2.40V
 DOMINANT WAVELENGTH IF=20mA ORANGE 600~612nm

PROFILE OF WAVE SOLDER:

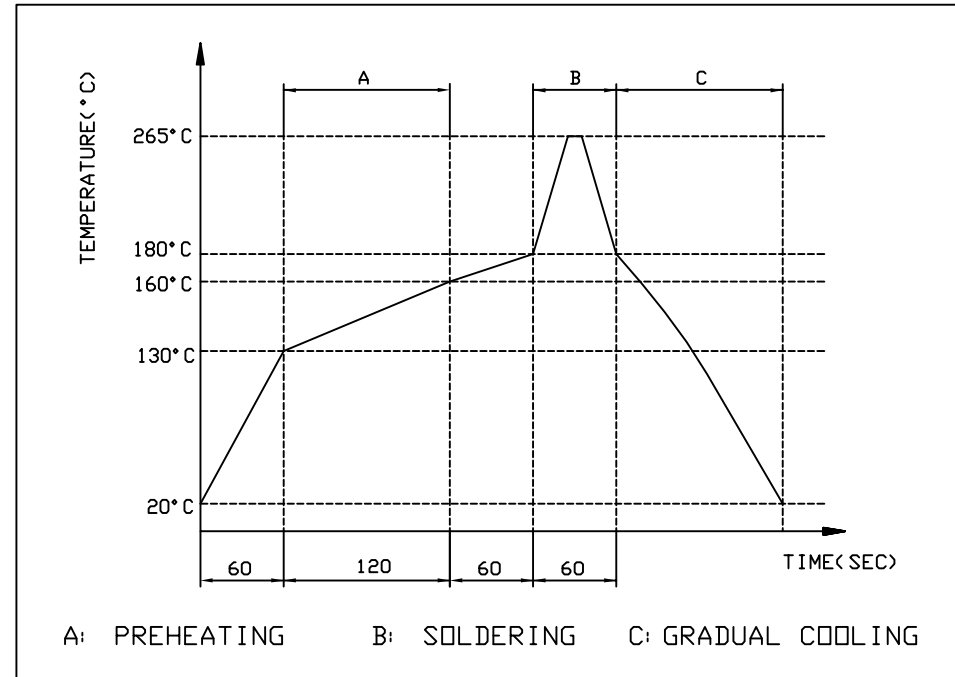

RECOMMENDED WAVE SOLDER CURVE

- (1) TIP TEMPERATURE: 265°C
- (2) TIP TEMPERATURE TIME: 10 SEC MAX.

X± /	X°. ± /	UNITS	NAME< INTENDED USE> CUSTOMER	FOXCONN FOXCONN INTERCONNECT TECHNOLOGY LIMITED.
. X± /	. X° ± /	MAT' L	PART NO. < INTENDED USE> JFM3811*-G140-*F	
. XX± /	. XX° ± /	FINISH	APPD: L. C. WU 05/29' 14	CLASS: <input type="checkbox"/> CONFIDENTIAL <input type="checkbox"/> SECRET <input checked="" type="checkbox"/> GENERAL
. XXX± /	. XXX° ± /		Q' TY	CHKD: J. H. HU 05/29' 14
THESE DRAWINGS AND SPECIFICATIONS ARE THE PROPERTY OF FOXCONN INTERCONNECT TECHNOLOGY LIMITED, AND SHALL NOT BE REPRODUCED, COPIED OR USED IN ANY MANNER WITHOUT THE PRIOR WRITTEN CONSENT OF FOXCONN INTERCONNECT TECHNOLOGY LIMITED.			DR: D. K. LIU 05/29' 14	DWG NO. : 305-0000-4768
				SCALE SHEET REV. N/A 4/5 A

8	LEDS	2		LED1/LED2	
7	MAGNETIC	1		NONE	
6	SHELL	1	METAL ALLOY	30~100u' NICKEL UNDERPLATING GROUNDING TAIL 50~200 u' MAT TIN ALLOY SELECT PLATING	
5	SOLDERTAILS	14	COPPER ALLOY	100u' MIN MAT TIN ALLOY AT SOLDERING AREA 50~200 u' NICKEL UNDERPLATING	
4	RJ45 CONTACT	8	PHOSPHOR BRONZE	30u' MIN GOLD AT CONTACT AREA 50~200 u' NICKEL UNDERPLATING	
3	RJ45 INSERT	1	THERMOPLASTIC UL 94V-0	BLACK	
2	SPACER	1	THERMOPLASTIC UL 94V-0	BLACK	
1	HOUSING	1	THERMOPLASTIC UL 94V-0	BLACK	
ITEM	DESCRIPTION	QUANTITY	MATERIAL	TREATMENT	REMARK

REMARK:

JFM 3 8 1 1 * - G 1 4 0 - * F

SERIES PREFIX:
JFM =RJ WITH
MAGNETIC,

CORE COUNT:
8 = 8 CORE,

PROTOCOL TYPE:
3 =10/100/1000

LEDS
SEE SHEET 2/5

PCB ATTACHMENT METHOD:
1 = SOLDER TAIL

CONFIGURATION:
1 = 1X1 T/U w/GROUNDING

FINISH:
F=LEAD FREE

PACKAGE TYPE:
4= SOFT TRAY
7= TAPE & REEL

FOXCONN EXTENSION CODE

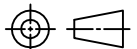
X± /	X° ± /	UNITS	NAME< INTENDED USE> CUSTOMER	FOXCONN FOXCONN INTERCONNECT TECHNOLOGY LIMITED.						
. X± /	. X° ± /	MAT' L	PART NO. < INTENDED USE>	CLASS: <input type="checkbox"/> CONFIDENTIAL <input type="checkbox"/> SECRET <input checked="" type="checkbox"/> GENERAL						
. XX± /	. XX° ± /	FINISH	JFM3811*-G140-*F	TITLE: RJ45 , 1X1, T/U, T/H, 10/1000						
. XXX± /	. XXX° ± /		APPD: L. C. WU 05/29' 14	DWG NO. : 305-0000-4768						
THESE DRAWINGS AND SPECIFICATIONS ARE THE PROPERTY OF FOXCONN INTERCONNECT TECHNOLOGY LIMITED, AND SHALL NOT BE REPRODUCED, COPIED OR USED IN ANY MANNER WITHOUT THE PRIOR WRITTEN CONSENT OF FOXCONN INTERCONNECT TECHNOLOGY LIMITED.		Q' TY	CHKD: J. H. HU 05/29' 14	 <table border="1"> <tr> <td>SCALE</td> <td>SHEET</td> <td>REV.</td> </tr> <tr> <td>N/A</td> <td>5/5</td> <td>A</td> </tr> </table>	SCALE	SHEET	REV.	N/A	5/5	A
SCALE	SHEET	REV.								
N/A	5/5	A								
			DR: D. K. LIU 05/29' 14							