

Conductive Plastic Motion Transducer Elements (KIT), up to 1000 mm

FEATURES

- Measurement range 25 mm to 1000 mm
- High accuracy $\pm 1\%$ down to $\pm 0.025\%$
- Good repeatability
- Simple and flexible mounting
- Essentially infinite resolution
Made in two separate parts:
 - the sensing element
 - the wiper
 Special designs available on request
- Material categorization: for definitions of compliance please see www.vishay.com/doc?99912

**RoHS
COMPLIANT**

The LMF is a reduced bulk, precision motion transducer, designed for easy integration into equipment.

QUICK REFERENCE DATA

Sensor type	LINEAR, conductive plastic
Output type	Solder pads
Market appliance	Industrial
Dimensions	L x 15 mm x 1.6 mm (with L = TET + 18 mm)

ELECTRICAL SPECIFICATIONS

Theoretical electrical angle (TEA = E)	From 25 mm to 1000 mm in increments of 25 mm	
Independent linearity (over TET)	$\leq \pm 1\%$; $\leq \pm 0.1\%$	
On request	$\leq \pm 0.05\%$ for $E \geq 100$ mm	$\leq \pm 0.025\%$ for $E \geq 200$ mm
Actual electrical travel (AET)	AET = TET + 2 mm	
Ohmic value	From 400 Ω /cm to 2 k Ω /cm	
Resistance tolerance at 20 °C	$\pm 20\%$	
Repeatability	$\leq 0.01\%$	
Maximum power rating	0.05 W/cm at 40 °C	0 W at 85 °C
Wiper current	Recommended: a few μ A - 1 mA max. (continuous)	
Load resistance	Minimum $10^3 \times R_T$	
Insulation resistance	≥ 1000 M Ω , 500 V _{DC}	
Dielectric strength	≥ 750 V _{RMS} , 50 Hz	

MECHANICAL SPECIFICATIONS

Support of element	Fiberglass epoxy
On request	Plastic moulding
Wiper (non insulated)	Precious metal multifinger
On request	Insulated
Terminals	Soldering pads
On request	By wires
Fixing	Glued: Double face Isotac
On request	Screwed: Holes in the support

PERFORMANCE

Operating life	25 million cycles typical/1 Hz/T° = 20 °C \pm 5 °C/80 % TET
Temperature range	-55 °C to +125 °C

Note

- Nothing stated herein shall be construed as a guarantee of quality or durability.

DIMENSIONS in millimeters, general tolerance ± 0.2 mm

STANDARD MODEL: LMF...W02851

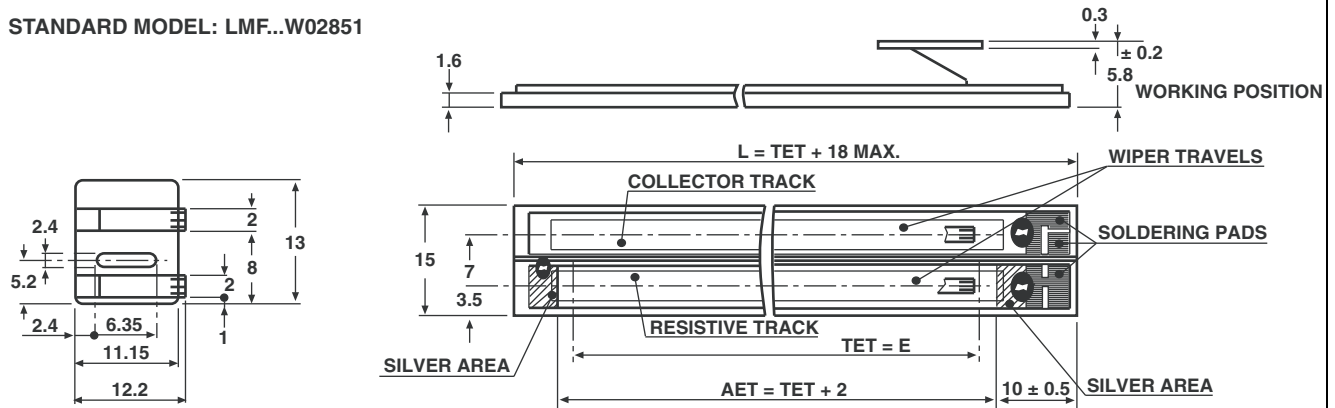
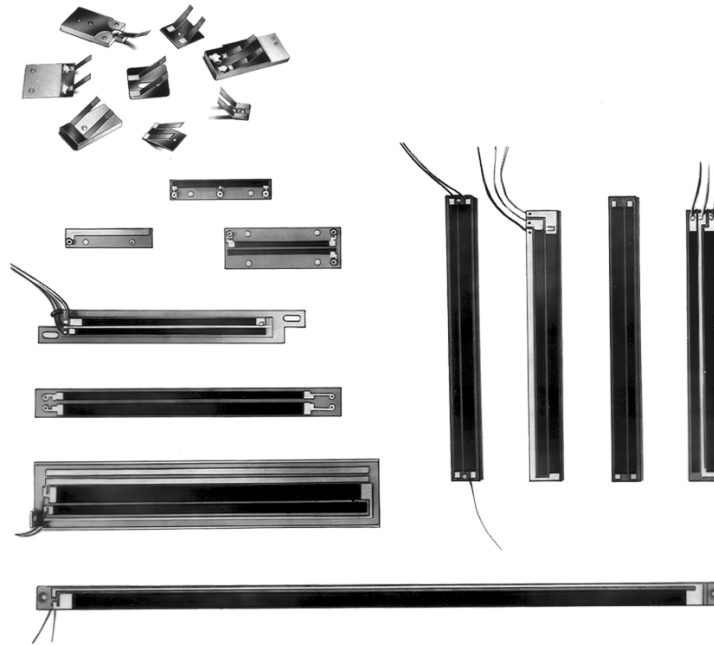
EXAMPLES OF SPECIAL DESIGNS

ORDERING INFORMATION/DESCRIPTION

KIT SERIES	LM MODEL	F CONDUCTOR	3 THEORETICAL ELECTRICAL TRAVEL	D LINEARITY	103 OHMIC VALUE	W... MODIFICATIONS	e. LEAD FINISH
		F: Plastic S: Serigraphy	Times 25 mm	A: $\pm 1\%$ D: $\pm 0.1\%$ E: $\pm 0.05\%$ F: $\pm 0.025\%$	First 2 digits are significant numbers 3rd digit indicates number of zeros	Special feature code number	

SAP PART NUMBERING GUIDELINES

LMF MODEL	3 TET	D LINEARITY	103 OHMIC VALUE	W... SPECIAL FEATURES
-----------	-------	-------------	-----------------	-----------------------



Disclaimer

ALL PRODUCT, PRODUCT SPECIFICATIONS AND DATA ARE SUBJECT TO CHANGE WITHOUT NOTICE TO IMPROVE RELIABILITY, FUNCTION OR DESIGN OR OTHERWISE.

Vishay Intertechnology, Inc., its affiliates, agents, and employees, and all persons acting on its or their behalf (collectively, "Vishay"), disclaim any and all liability for any errors, inaccuracies or incompleteness contained in any datasheet or in any other disclosure relating to any product.

Vishay makes no warranty, representation or guarantee regarding the suitability of the products for any particular purpose or the continuing production of any product. To the maximum extent permitted by applicable law, Vishay disclaims (i) any and all liability arising out of the application or use of any product, (ii) any and all liability, including without limitation special, consequential or incidental damages, and (iii) any and all implied warranties, including warranties of fitness for particular purpose, non-infringement and merchantability.

Statements regarding the suitability of products for certain types of applications are based on Vishay's knowledge of typical requirements that are often placed on Vishay products in generic applications. Such statements are not binding statements about the suitability of products for a particular application. It is the customer's responsibility to validate that a particular product with the properties described in the product specification is suitable for use in a particular application. Parameters provided in datasheets and / or specifications may vary in different applications and performance may vary over time. All operating parameters, including typical parameters, must be validated for each customer application by the customer's technical experts. Product specifications do not expand or otherwise modify Vishay's terms and conditions of purchase, including but not limited to the warranty expressed therein.

Except as expressly indicated in writing, Vishay products are not designed for use in medical, life-saving, or life-sustaining applications or for any other application in which the failure of the Vishay product could result in personal injury or death. Customers using or selling Vishay products not expressly indicated for use in such applications do so at their own risk. Please contact authorized Vishay personnel to obtain written terms and conditions regarding products designed for such applications.

No license, express or implied, by estoppel or otherwise, to any intellectual property rights is granted by this document or by any conduct of Vishay. Product names and markings noted herein may be trademarks of their respective owners.