

## HFB60HF20

### FRED

### Ultrafast, Soft Recovery Diode

#### Features

- Reduced RFI and EMI
- Reduced Snubbing
- Extensive Characterization of Recovery Parameters
- Hermetic
- Surface Mount

$V_R = 200V$
$I_{F(AV)} = 60A$
$t_{rr} = 50ns$

#### Description

These Ultrafast, soft recovery diodes are optimized to reduce losses and EMI/RFI in high frequency power conditioning systems. An extensive characterization of the recovery behavior for different values of current, temperature and di/dt simplifies the calculations of losses in the operating conditions. The softness of the recovery eliminates the need for a snubber in most applications. These devices are ideally suited for power converters, motors drives and other applications where switching losses are significant portion of the total losses.

#### Absolute Maximum Ratings

	Parameter	Max.	Units
$V_R$	Cathode to Anode Voltage	200	V
$I_{F(AV)}$	Continuous Forward Current, ① $T_C = 55^\circ C$	60	A
$I_{FSM}$	Single Pulse Forward Current, ② $T_C = 25^\circ C$	500	
$P_D @ T_C = 25^\circ C$	Maximum Power Dissipation	70	W
$T_J, T_{STG}$	Operating Junction and Storage Temperature Range	-55 to +150	$^\circ C$

**Note:** ① D.C. = 50% rect. wave  
 ② 1/2 sine wave, 60 Hz, P.W. = 8.33 ms

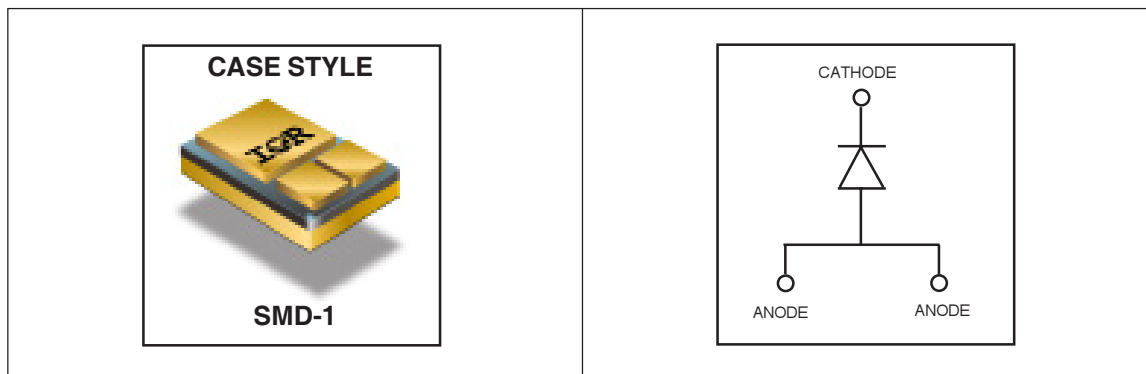

**Electrical Characteristics @  $T_J = 25^\circ\text{C}$  (unless otherwise specified)**

	Parameter	Min.	Typ.	Max.	Units	Test Conditions
$V_{BR}$	Cathode Anode Breakdown Voltage	200	—	—	V	$I_R = 100\mu\text{A}$
$V_F$	Forward Voltage See Fig. 1	—	—	1.15	V	$I_F = 30\text{A}$ , $T_J = -55^\circ\text{C}$
		—	—	0.97		$I_F = 30\text{A}$ , $T_J = 25^\circ\text{C}$
		—	—	1.08		$I_F = 60\text{A}$ , $T_J = 25^\circ\text{C}$
		—	—	1.30		$I_F = 120\text{A}$ , $T_J = 25^\circ\text{C}$
		—	—	0.8		$I_F = 30\text{A}$ , $T_J = 125^\circ\text{C}$
$I_R$	Reverse Leakage Current See Fig. 2	—	—	50	$\mu\text{A}$	$V_R = V_R$ Rated
		—	—	1.0	$\text{mA}$	$V_R = V_R$ Rated, $T_J = 125^\circ\text{C}$
$C_T$	Junction Capacitance, See Fig. 3	—	—	190	$\text{pF}$	$V_R = 200\text{V}$
$L_S$	Series Inductance	—	5.9	—	$\text{nH}$	Measured from center of cathode pad to center of anode pad

**Dynamic Recovery Characteristics @  $T_J = 25^\circ\text{C}$  (unless otherwise specified)**

	Parameter	Min.	Typ.	Max.	Units	Test Conditions
$t_{rr1}$	Reverse Recovery Time	—	45	50	ns	$T_J = 25^\circ\text{C}$ See Fig.
$t_{rr2}$		—	71	—		$T_J = 125^\circ\text{C}$ 5
$I_{RRM1}$	Peak Recovery Current	—	5.3	—	A	$T_J = 25^\circ\text{C}$ See Fig.
$I_{RRM2}$		—	10.3	—		$T_J = 125^\circ\text{C}$ 6
$Q_{rr1}$	Reverse Recovery Charge	—	120	—	nC	$T_J = 25^\circ\text{C}$ See Fig.
$Q_{rr2}$		—	366	—		$T_J = 125^\circ\text{C}$ 7
$di_{(rec)M}/dt1$	Peak Rate of Fall of Recovery Current	—	590	—	$\text{A}/\mu\text{s}$	$T_J = 25^\circ\text{C}$ See Fig.
$di_{(rec)M}/dt2$	During $t_b$	—	1290	—		$T_J = 125^\circ\text{C}$ 8

**Thermal - Mechanical Characteristics**

	Parameter	Typ.	Max.	Units
$R_{thJC}$	Junction-to-Case	—	1.76	$^\circ\text{C}/\text{W}$
Wt	Weight	2.6	—	g

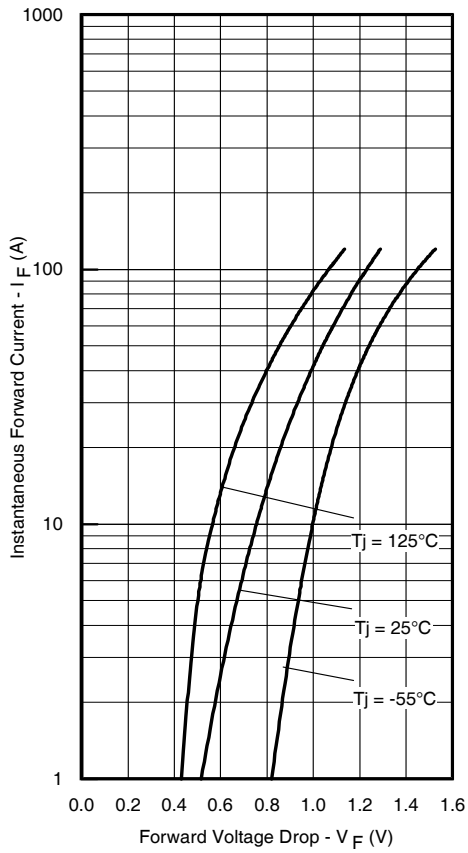

**Fig. 1** - Maximum Forward Voltage Drop Vs. Instantaneous Forward Current

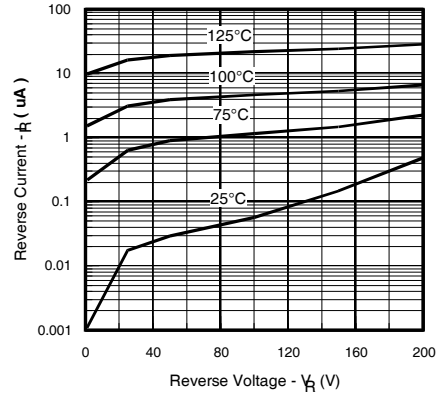

**Fig. 2** - Typical Reverse Current Vs. Reverse Voltage

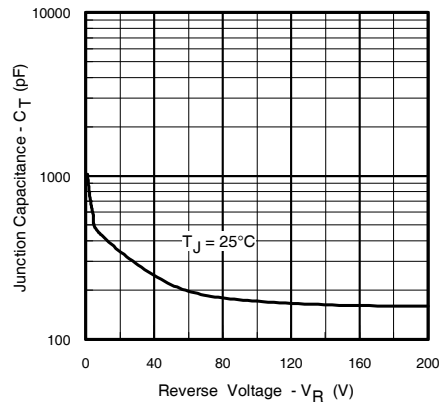

**Fig. 3** - Typical Junction Capacitance Vs. Reverse Voltage

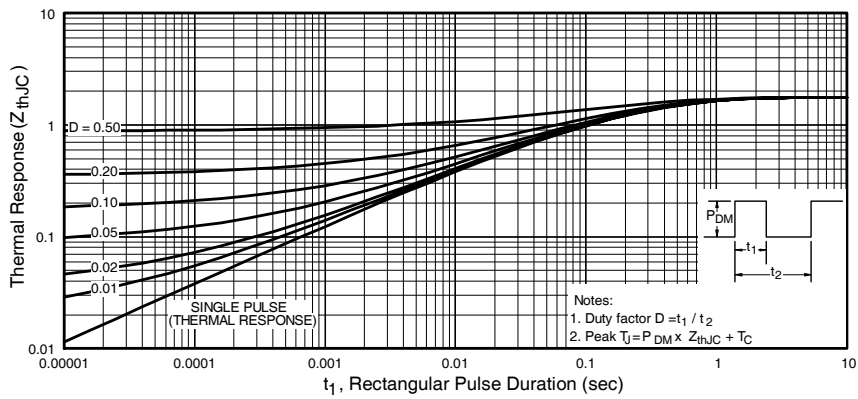

**Fig. 4** - Maximum Thermal Impedance  $Z_{thjC}$  Characteristics

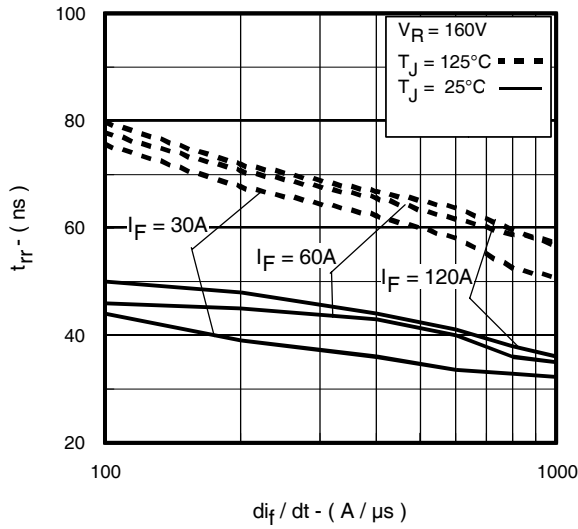

Fig. 5 - Typical Reverse Recovery Vs.  $di_f/dt$ ,

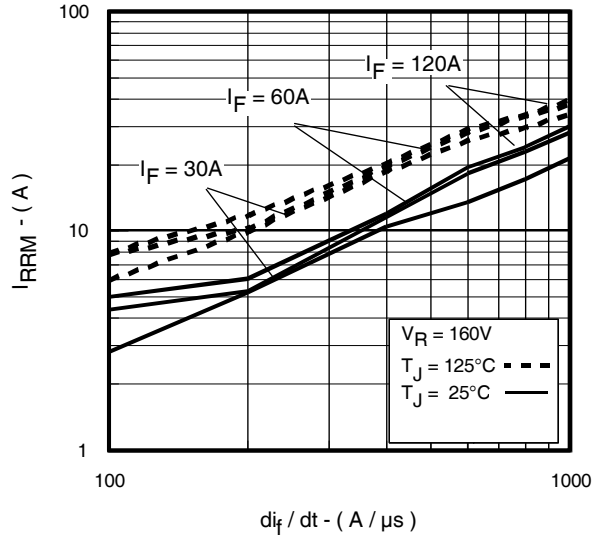

Fig. 6 - Typical Recovery Current Vs.  $di_f/dt$ ,

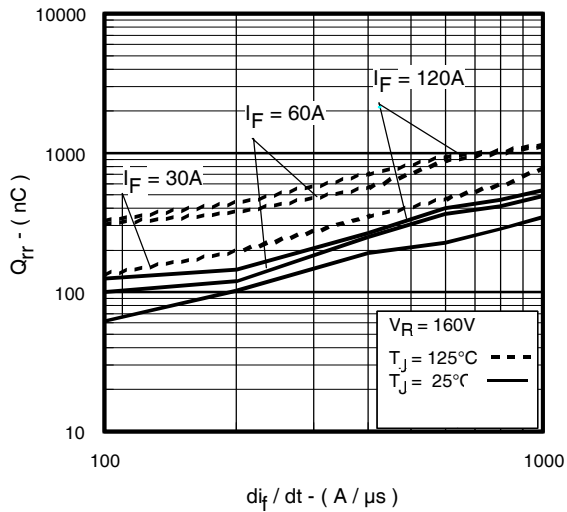

Fig. 7 - Typical Stored Charge Vs.  $di_f/dt$

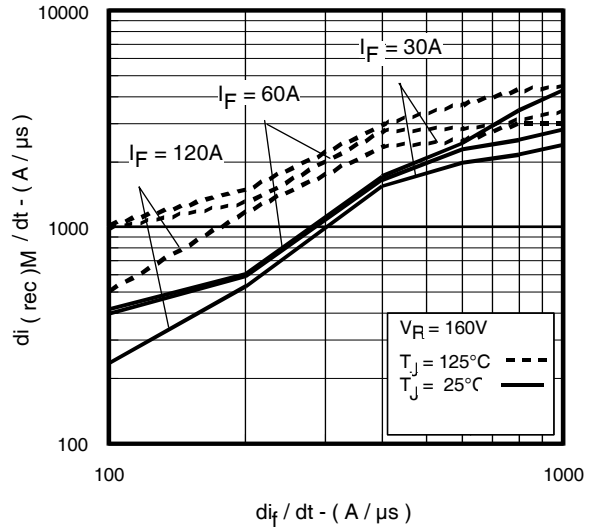
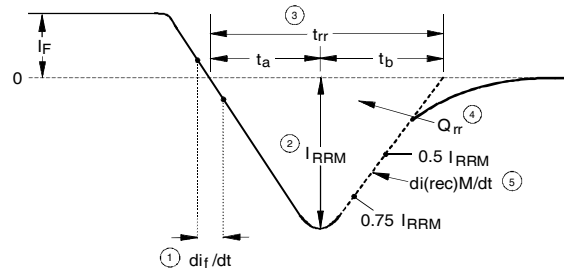
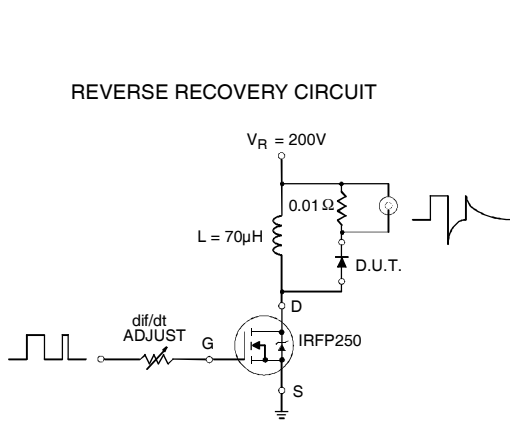

Fig. 8 - Typical  $di_{(rec)M}/dt$  Vs.  $di_f/dt$



1.  $di/dt$  - Rate of change of current through zero crossing
2.  $I_{RRM}$  - Peak reverse recovery current
3.  $t_{rr}$  - Reverse recovery time measured from zero crossing point of negative going  $I_F$  to point where a line passing through  $0.75 I_{RRM}$  and  $0.5 I_{RRM}$  extrapolated to zero current
4.  $Q_{rr}$  - Area under curve defined by  $t_{rr}$  and  $I_{RRM}$   

$$Q_{rr} = \frac{t_{rr} \times I_{RRM}}{2}$$
5.  $di_{(rec)M}/dt$  - Peak rate of change of current during  $t_b$  portion of  $t_{rr}$

Fig. 9 - Reverse Recovery Parameter Test Circuit

Fig. 10 - Reverse Recovery Waveform and Definitions

**Case Outline and Dimensions — SMD-1**

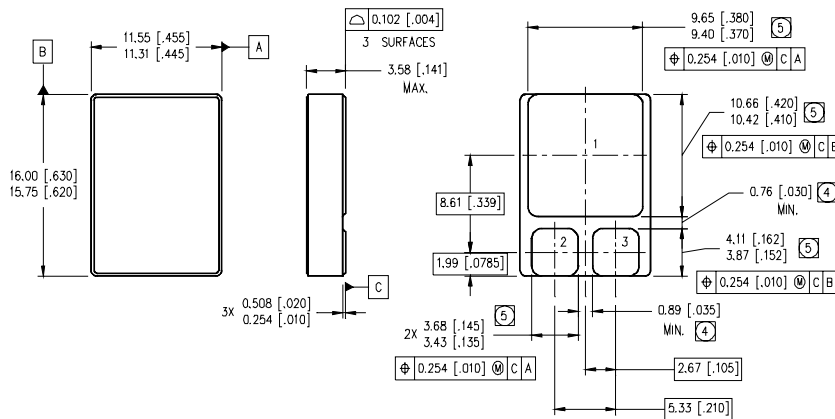

NOTES:

1. DIMENSIONING & TOLERANCING PER ASME Y14.5M-1994.
2. CONTROLLING DIMENSION: INCH.
3. DIMENSIONS ARE SHOWN IN MILLIMETERS [INCHES].
4. DIMENSION INCLUDES METALLIZATION FLASH.
5. DIMENSION DOES NOT INCLUDE METALLIZATION FLASH.

PAD ASSIGNMENTS

- 1 = CATHODE
- 2 = COMMON ANODE
- 3 = COMMON ANODE