

*開關產品未經SWITRONIC同意，請勿拆解，否則無法負品質及安全責任。
Please do not decompose the switch without any permission from SWITRONIC, otherwise the quality and safety responsibility could not be guaranteed.

*本圖面若與目錄之規格尺寸不符，以本圖面規格尺寸為主。
Below is our main specification if different from catalog.

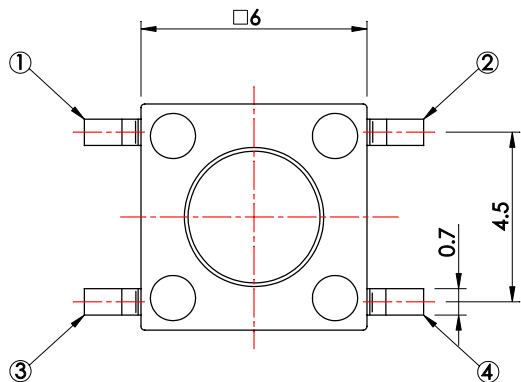

P.C.B. LAYOUT

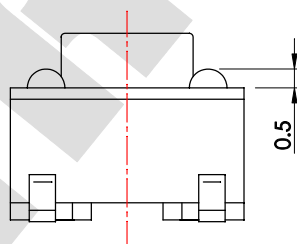
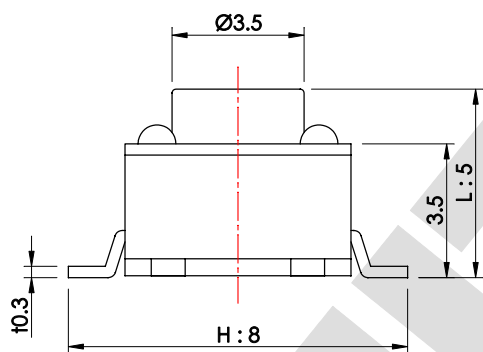
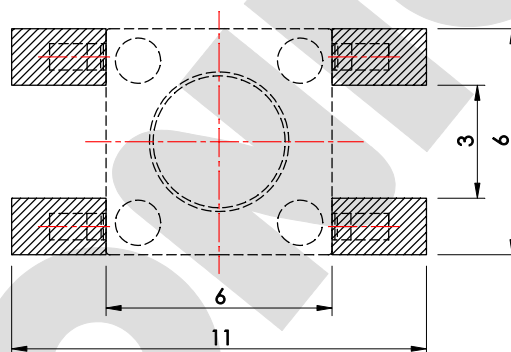

SCHEMATIC

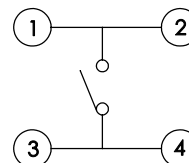

TERMINAL LENGTH (H)
8 or 9

OPERATING FORCE
100, 130, 160, 250

RoHS compliant

IT-1102WXXX-XXXG-G

MODEL NO.	L (mm)
□	4.3
A	5

STEM COLOR	□ Black
W White	
R Red	



SPECIFICATION

Rating: 50mA 12V DC.
Circuit: SPST.
Function: OFF-(ON).
Travel: 0.25±0.1 mm.
Contact resistance: 100mΩ Max.
Operating force: 100±50g.
Minimum load: 10mA 3.3V DC.(reference only)
Life: 100,000 Cycles.
Soldering temperature: 250°C Max. for 3 sec.
Soldering time: 1 time only.
Note1: Unwashable, don't be immersed by epoxy and organic solvent.
Note2: Please check the actual size, do not scale the drawing page.

EV2.1	△		
EV2.0	無	新繪製	2015.07.03
版本 VER.	符號 SYMBOL	修改內容 ALTERATION	更新日期 DATE

產品 PRODUCT		Tact Switch		型號 MODEL NO.		IT-1102WA8-100G-G	
比例 SCALE	5 : 1	單位 UNIT	mm				
公差 TOLERANCE	±0.3mm						
製圖 DRAWN BY	核圖 CHECKED BY	主管 APPROVED BY					
Allen Liao	Chuck Young	Margaret Lee					

SWITRONIC
INDUSTRIAL CORP.
Switches



一綺電子企業股份有限公司

總公司：110 台北市信義路四段415號13樓之3
13F-3 NO. 415, SEC. 4, HSIN YI ROAD, TAIPEI, TAIWAN
TEL : 886-2-27290229(Rep.) FAX : 886-2-27582086
URL : http://www.switronic.com.tw
E-MAIL : switches@ms36.hinet.net

一綺電子企業股份有限公司

SWITRONIC INDUSTRIAL CORP.

MODEL NO:IT-1102W Series

EV2.0

V.DATE: 2015/06/24

1. General

- 1.1 Application This specification is applied to TACT switches which have no keytop.
- 1.2 Operating temperature range
 : -10 ~ 60 °C (normal humidity,normal air pressure)
- 1.3 Storage temperature range
 : -5 ~ 40 °C (normal humidity,normal air pressure)
- 1.4 Test conditions Unless otherwise specified, the atmospheric conditions for marking measurements and tests are as follows.
- Normal temperature : (Temperature 5 ~ 35°C)
- Normal humidity : (Relative humidity 25 ~ 85%)
- Normal air pressure : (Air pressure 86 ~ 106kPa)
- If any doubt arise from judgement, tests shall be conducted at the following conditions.
- Ambient temperature : 20 ±2°C
- Relative humidity : 60 ~ 70%
- Air pressure : 86 ~ 106kPa

2. Appearance,style and dimensions

- 2.1 Appearance There shall be no defects that affect the service ability of the product.
- 2.2 Style & dimensions Refer to the assembly drawings.

3. Type of actuating Tactile feedback

4. Contact arrangement 1 pole 1 throw (Details of contact arrangement are given in the assembly drawings)

5. Rating

- 5.1 Maximum ratings 12 V DC 50 mA
- 5.2 Minimum ratings 3.3 V DC 10 mA

6. Electrical specification

	Items	Test conditions	Criteria
6.1	Contact resistance	Applying a blow static load to the center of the stem, measurements shall be made. (1) Depression : <u>520 gf</u> (5.096 N) (2) Measuring method : 1kHz small-current contact resistance meter or voltage drop method at 5V DC 10mA.	<u>100 mΩ</u> Max.
6.2	Insulation resistance	Measurements shall be made following the test set forth below : (1)Test voltage : <u>100</u> V DC for 1 min (2)Applied position : Between all terminals.And if there is a metal frame,between terminals and ground(frame)	<u>100 MΩ</u> Min.
6.3	Voltage proof	Measurements shall be made following the test set forth below : (1)Test voltage : <u>100</u> V AC (50 ~ 60 Hz) (2)Duration : 1 min (3)Applied position : Between all terminals.And if there is a metal frame,between terminals and ground(frame)	There shall be no breakdown.

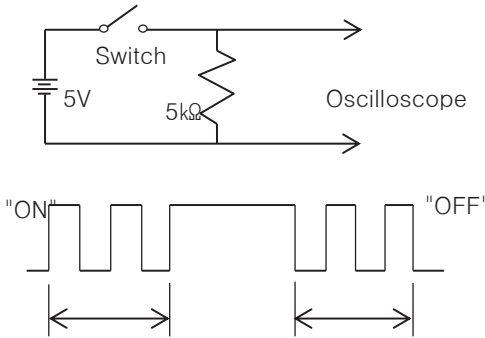

	Items	Test conditions	Criteria
6.4	Bounce	<p>Lightly striking the center of the stem at a rate encountered in normal use (3 to 4 operations per sec.) bounce shall be tested at "ON" and "OFF".</p> 	<p>ON bounce : <u>10</u> ms Max. OFF bounce : <u>10</u> ms Max.</p>

7. Mechanical specification

	Items	Test conditions	Criteria
7.1	Operating force	Placing the switch such that the direction of switch operation is vertical and then gradually increasing the load applied to the center of the stem, the maximum load required for the switch to come to a stop shall be measured.	<u>100</u> ± 50 gf
7.2	Travel	Placing the switch such that the direction of switch operation is vertical and then applying static load to the center of the stem, the travel distance for the switch to come to a make "ON" shall be measured.	<u>0.25</u> ± 0.1 mm
7.3	Return force	The sample switch is installed such that the direction of switch operation is vertical and, upon depression of the stem in its center the travel distance, the force of the stem to return to its free position shall be measured.	<u>40</u> gf Min. (0.39 N Min.)
7.4	Stop strength	Placing the switch such that the direction of switch operation is vertical and then a below static load shall be applied in the direction of stem operation. (1) Depression : <u>3</u> Kgf (29.4 N) (2) Duration : <u>3</u> s	There shall be no sign of damage mechanically and electrically.

8. Environmental specification

	Items	Test conditions	Criteria
8.1	Resistance to low temperatures	Following the test set forth below the sample shall be left in normal temp' and humidity conditions for 1 hour before measurements are made: (1) Temperature : <u>-30</u> ± 2 °C (2) Time : <u>96</u> h (3) Waterdrops shall be removed.	Item 6. Item 7.1 Item 7.2

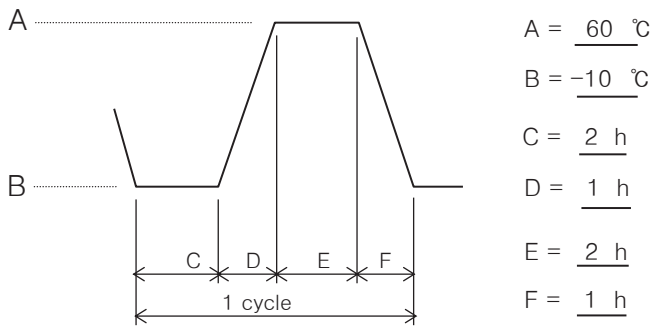

Items	Test conditions	Criteria
Heat resistance	Following the test set forth below the sample shall be left in normal temperature and humidity conditions for 1 hour before measurements are made: (1) Temperature : <u>80</u> ± 2 °C (2) Time : <u>96</u> h	Item 6. Item 7.1 Item 7.2
Moisture resistance	Following the test set forth below the sample shall be left in normal temperature and humidity condition for 1 hour before measurements are made: (1) Temperature : <u>60</u> ± 2 °C (2) Time : <u>96</u> h (3) Relative humidity : <u>90</u> ~ <u>95</u> % (4) Waterdrops shall be removed.	Contact resistance (Item 6.1) : <u>200</u> mΩMax. Insulation resistance (Item 6.2) : <u>10</u> MΩ Min. Bounce (Item6.4) : ON bounce <u>20</u> ms Max. : OFF bounce <u>20</u> ms Max. Item 6.3, 7.2, 7.1
Change of temperature	After the test by following conditions, the switch shall be allowed to stand under normal room temperature and humidity conditions for 1 hour, and measurement shall be made. Water drops shall be removed. (1) Times of cycles : <u>5</u> times  <p style="text-align: right;"> A = <u>60</u> °C B = <u>-10</u> °C C = <u>2</u> h D = <u>1</u> h E = <u>2</u> h F = <u>1</u> h </p>	Item 6. Item 7.1 Item 7.2

9. Endurance specification

	Items	Test conditions	Criteria
9.1	Operating life Measurements shall be made following the test set forth below : (1) <u>12</u> V DC <u>50</u> mA resistive load (2) Rate of operation : <u>2</u> to <u>3</u> operations per sec. (3) Depression : The maximum load of a specification of the operating force. (4) Cycles of operation : <u>100,000</u> cycles	Contact resistance (Item 6.1) : <u>200</u> mΩMax. Insulation resistance (Item 6.2) : <u>10</u> MΩ Min. Bounce (Item6.4) : ON bounce <u>20</u> ms Max. : OFF bounce <u>20</u> ms Max. Operating force (Item7.1) : <u>±30</u> % of initial force Item 6.3, 7.2	



Items	Test conditions	Criteria
9.2 Vibration resistance	Measurements shall be made following the test set forth below : (1) Vibration frequency range : <u>10</u> ~ 55 Hz (2) Total amplitude : <u>1.5</u> mm (3) Sweep ration : <u>10-55-10</u> Hz Approx. 1 min (4) Method of changing the sweep vibration frequency : Logarithmic or uniform (5) Duration : <u>2</u> h each	Item 6. Item 7.1 Item 7.2
9.3 Shock	Measurements shall be made following the test set forth below: (1) Acceleration : <u>784</u> m/s ² (2) Test direction : 6 directions (3) Number of shocks : <u>3</u> times per direction (<u>18</u> times in total)	Item 6. Item 7.1 Item 7.2

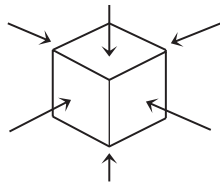

10. Soldering conditions

Items	Recommended conditions
10.1 Hand soldering	Please practice according to below conditions. (1) Soldering temperature : <u>350</u> °C Max. (2) Continuous soldering time : <u>3</u> seconds Max. (3) Excessive pressure shall not be applied to the terminal.
10.2 Reflow soldering	Please practice according to below conditions. (1) Preheat : Temperature on the copper foil surface should reach 180°C, <u>2 ± 0.3</u> minutes after the PCB entered into the soldering equipment (2) Soldering heat : Temperature on the copper foil surface should reach the peak temperature of <u>250</u> °C within <u>30</u> seconds after the PCB entered into soldering heat zone. (3) Soldering time : 1 time only.

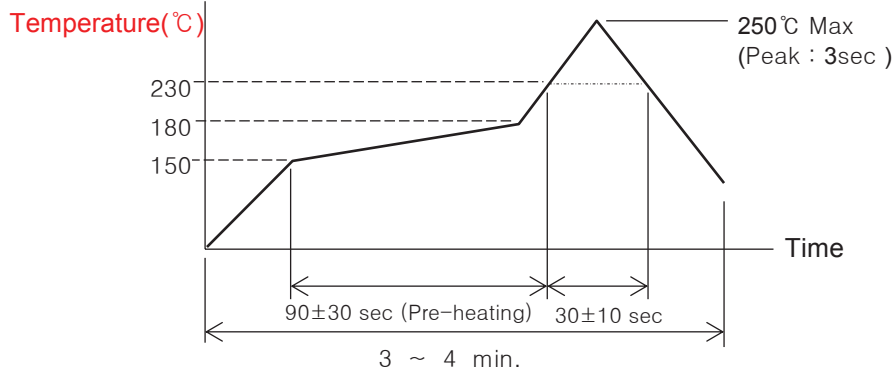

Time inside soldering equipment

一綺電子企業股份有限公司 SWITRONIC INDUSTRIAL CORP.

入料包裝方式 Packing for Products

管裝方式 Packing for tube

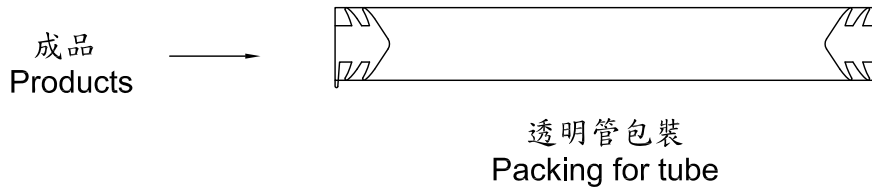

Packing for tube : _____ pcs / tube.

捲裝方式 Packing for reel

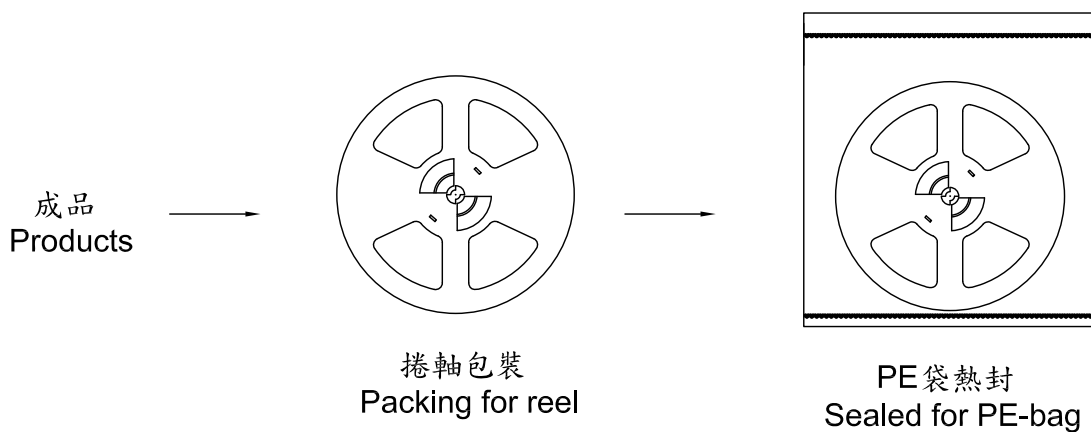

Packing for reel : 1,000 pcs / reel , 1 reel / polybag.

Quantity thickness for polybag : 0.08 mm , Quantity desiccating agent : 1 pcs.

一綺電子企業股份有限公司 SWITRONIC INDUSTRIAL CORP.

產品綠色環保標章

"G" Mark for All RoHS Compliant Products

環保標章式樣

Initial "G": Standing for Green Label



外箱標示

Marked on The Outside of Carton As:

