

Current Mode PWM Power Switch

Features

- Current mode PWM
- Very low startup current
- Under-voltage lockout (UVLO)
- Non-audible-noise green-mode control
- Fixed switching frequency of 65KHz
- Cycle-by-cycle peak current limiting
- Internal leading-edge blanking
- Internal slope compensation
- Less than 0.1w of power saving
- Over-voltage protection (OVP) on VCC Pin
- Over-load protection (OLP)

Applications

- Switching AC/DC power battery charger
- Digital camera
- Open-frame SMPS
- PDA power supply

Description

GR8937L integrates a PWM controller and high voltage power MOSFET of 650V. GR8937L has the features of very low startup current and current mode PWM control with green-mode function at light load. These features enable the power supply to easily meet even the strictest power conservation requirements. The integrated functions of GR8937L also include the leading-edge blanking of the current sensing, internal slope compensation, cycle-by-cycle peak current limiting and soft start. OCP, OVP and OLP provide protection performance for fault conditions. To protect the power MOSFET from being damaged by supply over voltage, the internal gate voltage of GR8937L is clamped at 15V. GR8937L improves the performance and reduces the cost of power supplies.

Ordering and Marking Information

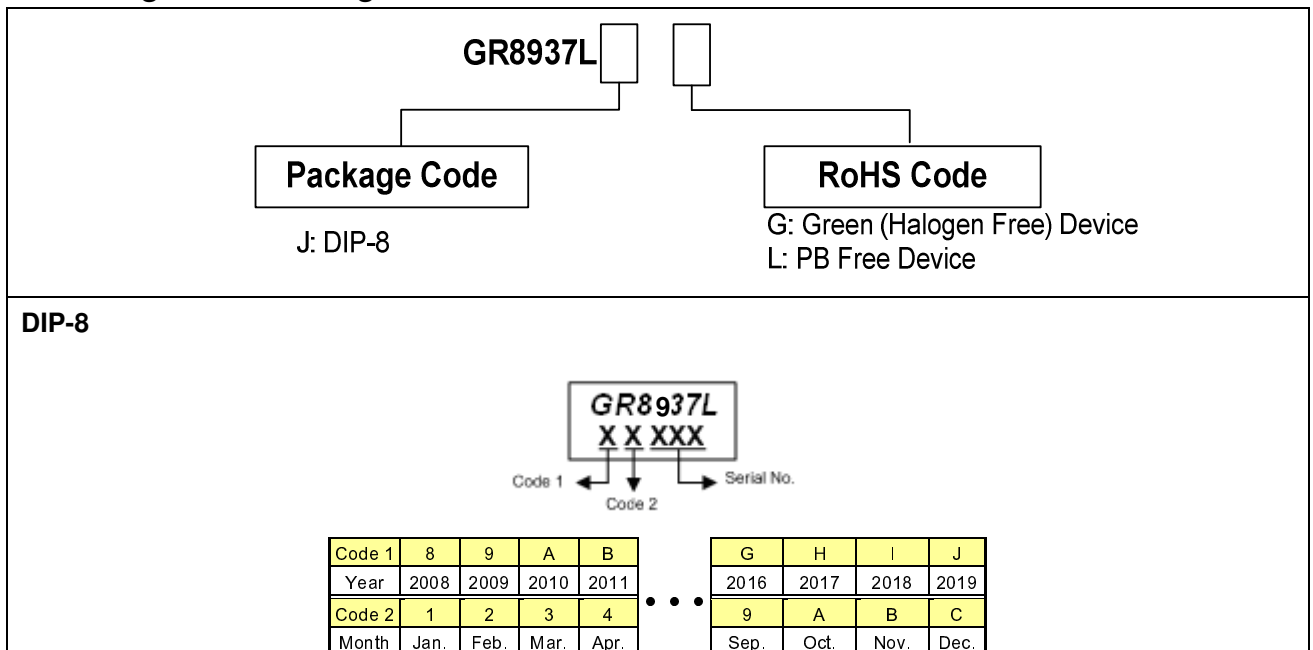

Greenergy OPTO Inc. reserves the right to make changes to improve reliability or manufacture ability without notice, and advise customers to obtain the latest version of relevant information to verify before placing orders.

Pin Configuration

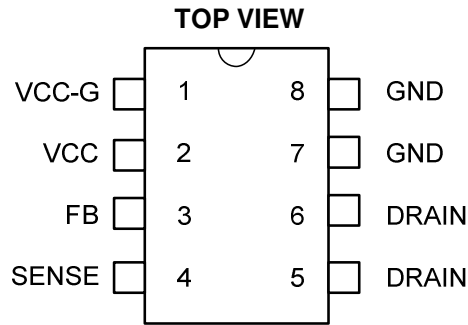

Pin Description

Pin No.	Symbol	Description
1	VCC-G	Power supply input for internal gate driver
2	VCC	Power supply input for IC
3	FB	Voltage feedback pin, by connecting a photo-coupler to control the duty cycle
4	SENSE	Current sense pin
5, 6	DRAIN	Drain of internal HV MOS
7, 8	GND	Ground

Recommended Operating Conditions

Item	Min.	Max.	Unit
Supply voltage VCC	11	25	V
VCC-G pin series resistor	51	510	Ohm
VCC pin series resistor	10	75	Ohm
FB pin capacitor	1	100	nF

Note: 1. FB pin parallel one 6.5V Zener diode for Safety Regulation on abnormal test.

2. Sense pin resistor recommended to use SMD type for avoiding stray inductor interference issue.

Recommended Output Power Range

Part No.	90~264Vac	
	Open frame	Adaptor
GR8937L	15W	12W

Absolute Maximum Ratings

Drain voltage	-----	-0.3V ~ 650V
Supply voltage VCC	-----	30V
VCC-G	-----	30V
FB sense	-----	-0.3 ~ 7V
Max operating junction temperature	-----	150°C
Operating ambient temperature	-----	-20°C ~ 85°C
Storage temperature range	-----	-65°C ~ 150°C
Lead temperature (All Pb free packages, soldering, 10 sec)	-----	260°C



Electrical Characteristics (VCC=15.0V & TA = +25°C, unless otherwise specified.)

Parameter	Pin	Min.	Typ.	Max.	Unit
SUPPLY VOLTAGE					
Startup current	2		7	20	uA
Operating current, VFB = 2.5V	2		2.5		mA
UVLO (off)	2		9		V
UVLO (on)	2		15		V
OVP level on VCC pin	2	27	28	29	V
VOLTAGE FEEDBACK					
Short circuit current, Vcomp = 0V	3			0.8	mA
Open loop voltage, COMP pin open	3		5.7		V
CURRENT SENSING					
Maximum input voltage	4	0.8	0.85	0.9	V
Leading-edge blanking time	4		350		nS
Input impedance	4		300		KΩ
Delay to output	4		100		nS
OSCILLATOR					
Frequency	-	60	65	70	KHz
Green mode frequency			22		KHz
Temp. stability (-40°C ~ 110°C)	-		5		%
Voltage stability (VCC = 11V ~ 25V)	-		3		%
MOSFET SECTION					
Vds	5 & 6		650		V
Rds (on)	5 & 6		4		Ω
Drain current-continuous	5 & 6		1.5		A
Drain current-pulsed			12		A
OLP					
OLP delay time	-		60		ms
OLP trim level	-		3.45		V

Application Information

Start-up Current

The typical start-up current is 8uA. Very low start-up current allows the PWM controller to increase the value of start-up resistor and then reduce the power dissipation on it.

Under-voltage Lockout (UVLO)

A hysteresis UVLO comparator is implemented in GR8937L, then the turn-on and turn-off thresholds level are fixed at 15V and 9V respectively. This hysteresis shown in Fig. 7 ensures that the start-up capacitor will be adequate to supply the chip during start-up.

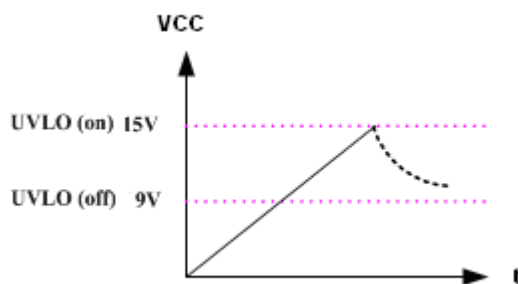

Fig. 7

Soft Start

During initial power on, GR8935L provides soft start function. It effectively suppresses the start up peak current to reduce the power MOSFET drain voltage especially at high line.

Oscillator

The frequency of the oscillator is fixed internally at about 65kHz. The maximum duty-cycle of internal oscillator is limited about 75% to avoid the transformer saturation.

Green Mode Operation

When the load decreases to an extent, the frequency of the controller will decrease so as to reduce the system power consumption. The

minimum frequency is about 22KHz, which is outside the audio range.

Leading-edge Blanking (LEB)

Each time the power MOSFET is switched on, a turn-on spike will inevitably occur at the sense resistor. To avoid fault trigger, a 350ns leading-edge blanking time is built in. Conventional RC filtering can therefore be omitted. During this blanking period, the current-limit comparator is disabled and can not switch off the gate driver.

Internal Slope Compensation

A built-in slope compensation circuit is constructed in GR8937L. When the switch is on, a ramp voltage is added to the sensed voltage across the Sense, which helps to stabilize the system and prevent sub-harmonic oscillations.

Over-load Protection (OLP)

The controller has over load protection function. An internal circuit detects the load level, when the load is larger than a threshold and the condition lasts more than 60ms, the gate output will keep low level. Then VCC decreases below UVLO off level, the controller resets again.

Over-voltage Protection (OVP) on VCC

To prevent power MOSFET from being damaged, GR8937L is implemented an OVP function on VCC. When the VCC voltage is higher than the OVP threshold voltage, the output gate driver circuit will be shut down immediately to stop the switching of internal HV power MOSFET.

The VCC OVP function is an auto-recovery type protection. If OVP happens, the pulses will be stopped and recover at the next UVLO on. GR8937L is working in a hiccup mode.

Gate Driver

Driving capability can be adjusted by a resistor between VCC and VCC-G for EMI improvement. The resistor can decrease rising time of internal gate driver. But be attention that too large resistance could decrease system efficiency (especially at CCM condition).

Typical Application Circuit

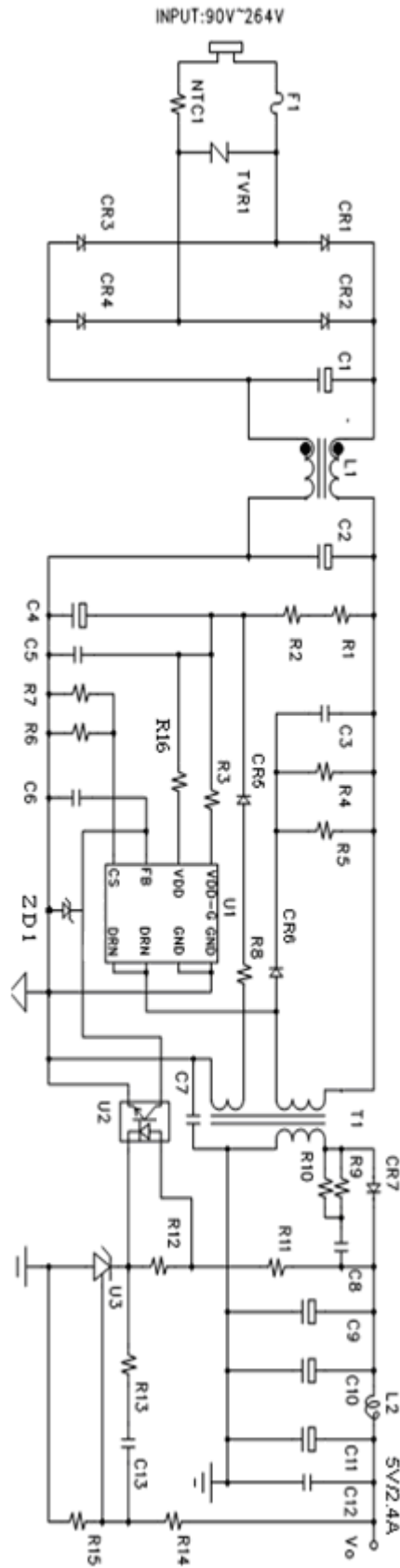

BOM List

No.	Part.No	Description	Note
1	C1	E-CAP 400V/10uF	
2	C2	E-CAP 400V/10uF	
3	C3	332/1KV	
4	C4	E-CAP 50V/10uF	
5	C5	SMD0805,104	
6	C6		N.C
7	C7		N.C
8	C8	SMD0805,222	
9	C9	E-CAP 10V/1000uF	
10	C10	E-CAP 10V/1000uF	
11	C11	E-CAP 16V/330uF	
12	C12	SMD0805,104	
13	C13	SMD0805,104	
14	CR1	1N4007	
15	CR2	1N4007	
16	CR3	1N4007	
17	CR4	1N4007	
18	CR5	FR104	
19	CR6	FR107	
20	CR7	SR540	
21	F1	250V/1A	
22	L1		30mH
23	L2	R3*5	1.0uH

No.	Part.No	Description	Note
24	NTC1	5Ω	
25	R1	SMD1206 / 105	
26	R2	SMD1206 / 514	
27	R3	SMD0805/ 511	
28	R4	SMD1206 / 104	
29	R5	SMD1206 / 683	
30	R6	SMD1206 / 2.7R	
31	R7	SMD1206 / 2.2R	
32	R8	SMD0805 / 0R	
33	R9	SMD1206 / 33R	
34	R10		N.C
35	R11	SMD0805/ 221	
36	R12		N.C
37	R13	SMD0805 / 202	
38	R14	SMD0805 / 472	1%
39	R15	SMD0805 / 472	1%
40	R16	SMD0805/ 47R	
41	J1	Jumper	
42	J2	SMD1206 / 0R	
43	T1	EE19	1.77mH
44	TVR1		N.C
45	U1	GR8937L	DIP8
46	U2	EL817	
47	U3	GL431	
48	ZD1	6.5V	

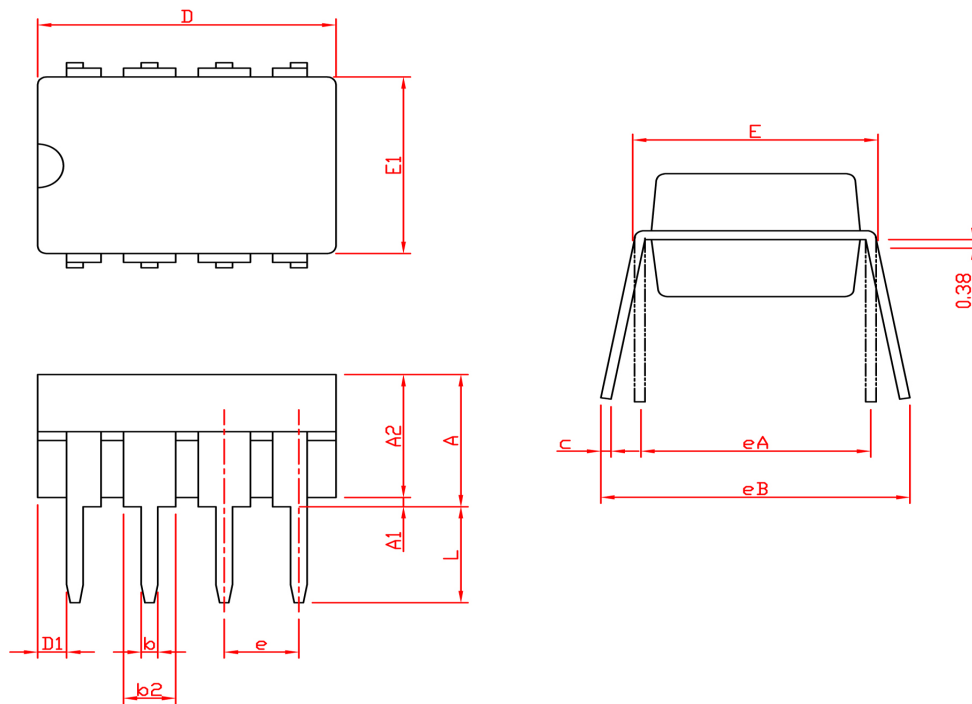
Package Information

SYMBOL	DIP-8			
	MILLIMETERS		INCHES	
	MIN.	MAX.	MIN.	MAX.
A		5.33		0.210
A1	0.38		0.015	
A2	2.92	4.95	0.115	0.195
b	0.36	0.56	0.014	0.022
b2	1.14	1.78	0.045	0.070
c	0.20	0.35	0.008	0.014
D	9.01	10.16	0.355	0.400
D1	0.13		0.005	
E	7.62	8.26	0.300	0.325
E1	6.10	7.11	0.240	0.280
e	2.54 BSC		0.100 BSC	
eA	7.62 BSC		0.300 BSC	
eB		10.92		0.430
L	2.92	3.81	0.115	0.150

Note: 1. Followed from JEDEC MS-001 BA.

- Dimension D, D1 and E1 do not include mold flash or protrusions. Mold flash or protrusions shall not exceed 10 mil.

Greenergy OPTO, Inc. reserves the right to make corrections, modifications, enhancements, improvements, and other changes to its products and services at any time and to discontinue any product or service without notice. Customers should obtain the latest relevant information before placing orders and should verify that such information is current and complete.