

TOSHIBA CMOS Digital Integrated Circuit Silicon Monolithic

TC74VCXH16543FT

Low-Voltage 16-Bit Registered Transceiver with Bushold

The TC74VCXH16543FT is a high-performance CMOS 16-bit registered transceiver. Designed for use in 1.8-V, 2.5-V or 3.3-V systems, it achieves high-speed operation while maintaining the CMOS low power dissipation.

The TC74VCXH16543FT can be used as two 8-bit transceivers or one 16-bit transceiver. Separate latch-enable ($\overline{\text{LEAB}}$ or $\overline{\text{LEBA}}$) and output-enable ($\overline{\text{OEAB}}$ or $\overline{\text{OEBA}}$) inputs are provided for each register to permit independent control in either direction of data flow.

The A-to-B enable ($\overline{\text{CEAB}}$) input must be low in order to enter data from A or to output data from B. If $\overline{\text{CEAB}}$ is low and $\overline{\text{LEAB}}$ is low, the A-to-B latches are transparent; a subsequent low-to-high transition of $\overline{\text{LEAB}}$ puts the A latches in the storage mode. With $\overline{\text{CEAB}}$ and $\overline{\text{OEAB}}$ both low, the 3-state B outputs are active and reflect the data present at the output of the A latches.

Data flow from B to A is similar but requires using the $\overline{\text{CEBA}}$, $\overline{\text{LEBA}}$, and $\overline{\text{OEAB}}$ inputs.

When the $\overline{\text{OE}}$ input is high, the outputs are in a high-impedance state. This device is designed to be used with 3-state memory address drivers, etc.

The A, B data inputs include active bushold circuitry, eliminating the need for external pull-up resistors to hold unused or floating data inputs at a valid logic level.

All inputs are equipped with protection circuits against static discharge.

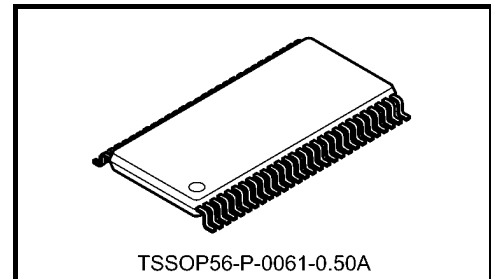

Weight: 0.25 g (typ.)

Features (Note)

- Low-voltage operation: $V_{CC} = 1.8$ to 3.6 V
- Bushold on data inputs eliminating the need for external pull-up/pull-down resistors
- High-speed operation: $t_{pd} = 3.5$ ns (max) ($V_{CC} = 3.0$ to 3.6 V)
 : $t_{pd} = 4.0$ ns (max) ($V_{CC} = 2.3$ to 2.7 V)
 : $t_{pd} = 8.0$ ns (max) ($V_{CC} = 1.8$ V)
- 3.6-V tolerant control inputs
- Output current: $I_{OH}/I_{OL} = \pm 24$ mA (min) ($V_{CC} = 3.0$ V)
 : $I_{OH}/I_{OL} = \pm 18$ mA (min) ($V_{CC} = 2.3$ V)
 : $I_{OH}/I_{OL} = \pm 6$ mA (min) ($V_{CC} = 1.8$ V)
- Latch-up performance: -300 mA
- ESD performance: Machine model $\geq \pm 200$ V
 Human body model $\geq \pm 2000$ V
- Package: TSSOP

Note: Do not apply a signal to any bus pins when it is in the output mode. Damage may result.

Pin Assignment (top view)

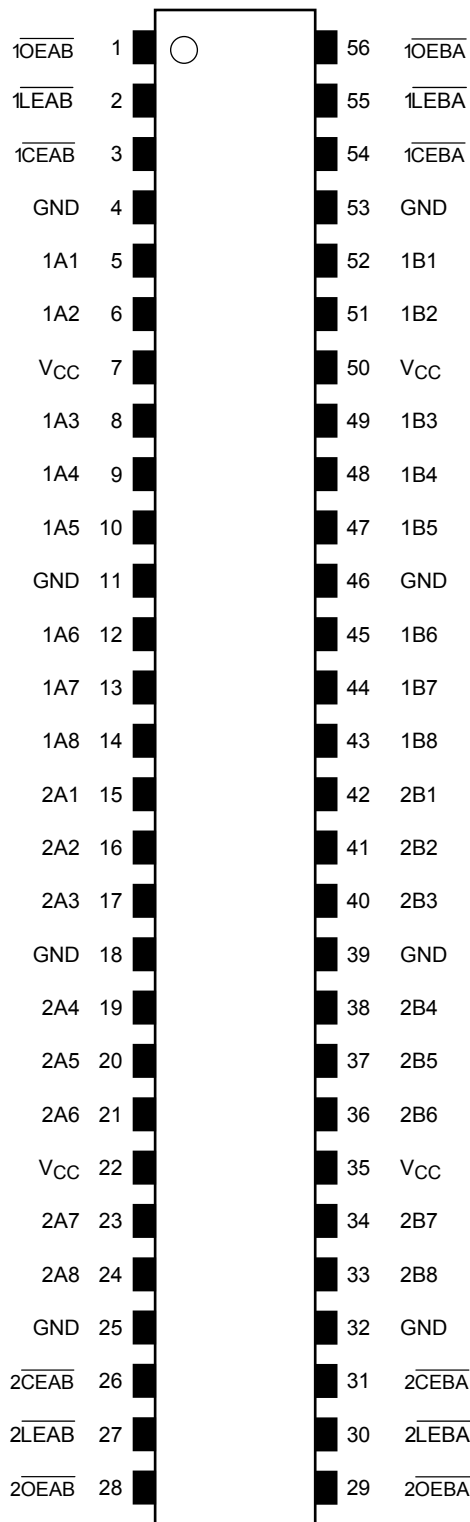

IEC Logic Symbol

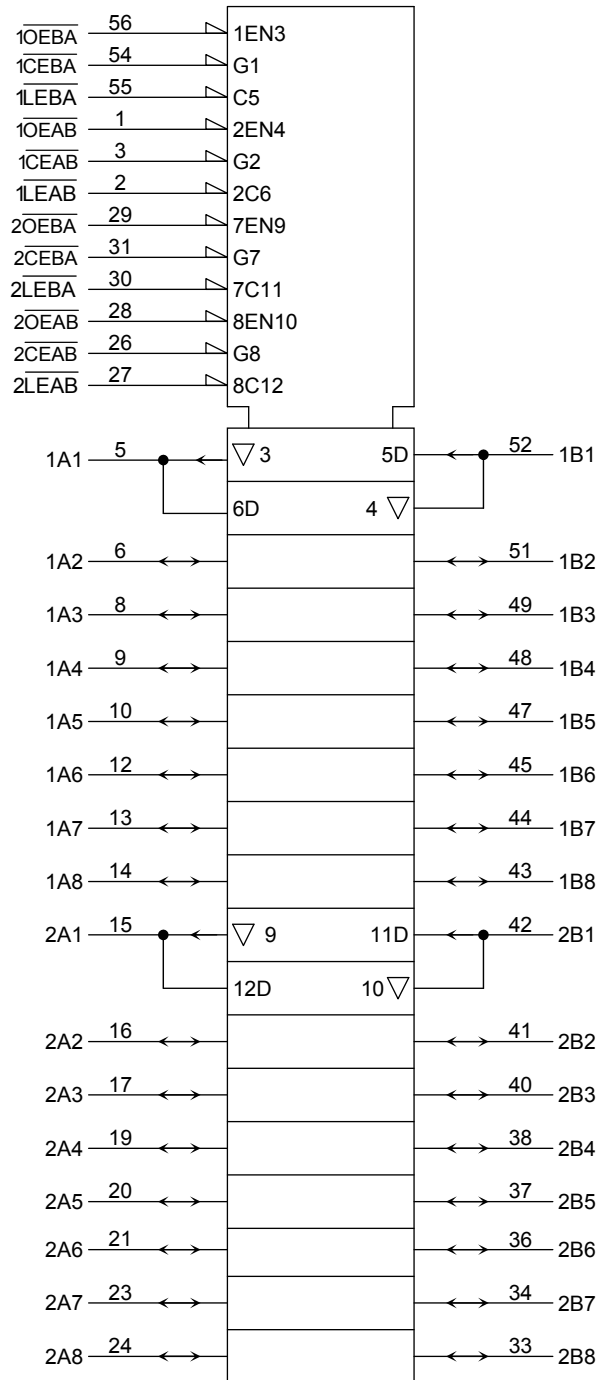

Truth Table (A bus → B bus each 8-bit latch)

Inputs				Outputs B
\overline{CEAB}	\overline{LEAB}	\overline{OEAB}	A	
H	X	X	X	Z
X	X	H	X	Z
L	H	L	X	B0 (Note)
L	L	L	L	L
L	L	L	H	H

Note: Output level before the indicated steady-state input conditions were established.

Truth Table (B bus → A bus each 8-bit latch)

Inputs				Outputs A
\overline{CEBA}	\overline{LEBA}	\overline{OEBA}	B	
H	X	X	X	Z
X	X	H	X	Z
L	H	L	X	A0 (Note)
L	L	L	L	L
L	L	L	H	H

Note: Output level before the indicated steady-state input conditions were established.

System Diagram

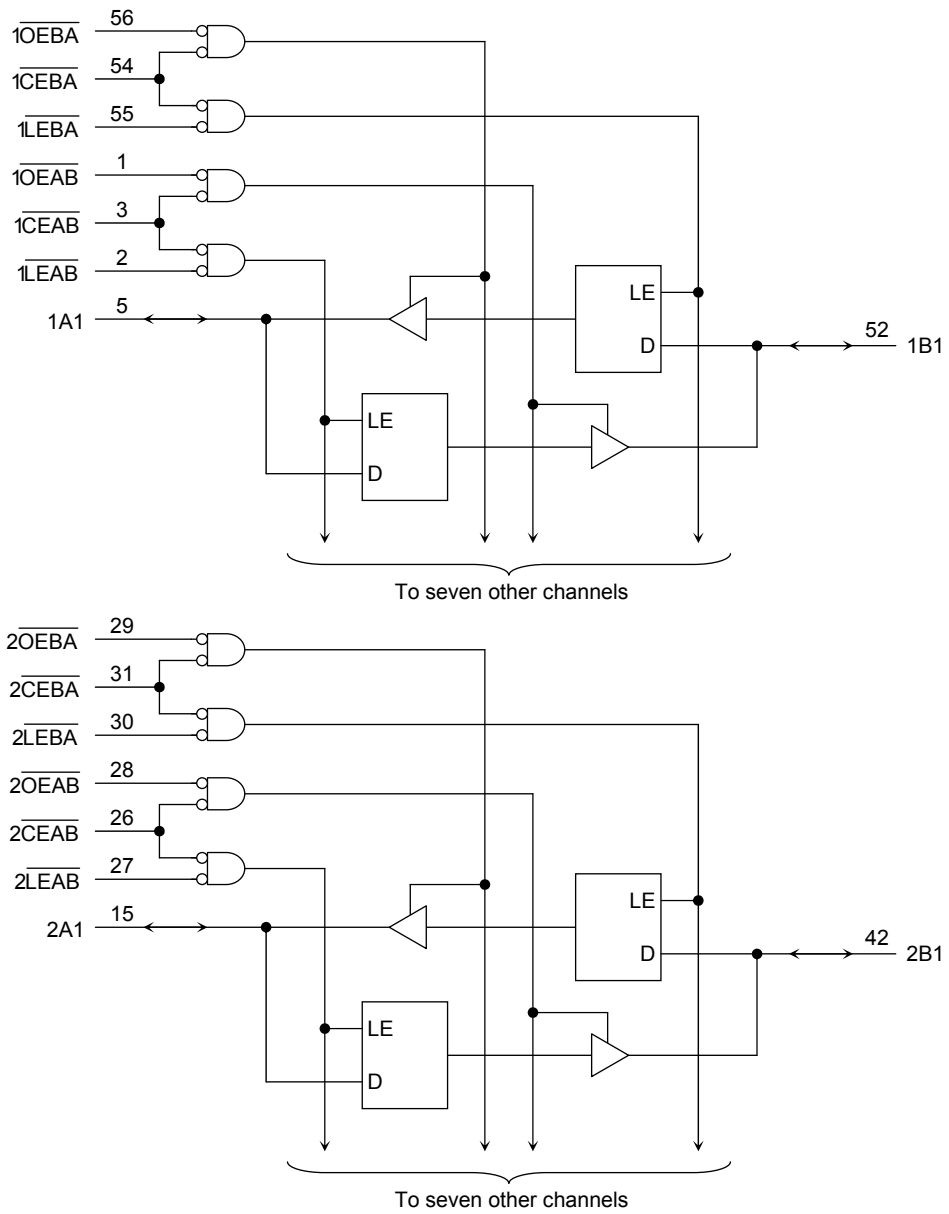

Absolute Maximum Ratings (Note 1)

Characteristics		Symbol	Rating	Unit
Power supply voltage		V_{CC}	-0.5 to 4.6	V
DC input voltage	(\overline{OEAB} , \overline{OEBA} , \overline{LEAB} , \overline{LEBA} , \overline{CEAB} , \overline{CEBA})	V_{IN}	-0.5 to 4.6	V
	(An, Bn)		-0.5 to $V_{CC} + 0.5$ (Note 2)	
DC output voltage	(An, Bn)	V_{OUT}	-0.5 to $V_{CC} + 0.5$ (Note 3)	V
Input diode current		I_{IK}	-50	mA
Output diode current		I_{OK}	± 50 (Note 4)	mA
Output current		I_{OUT}	± 50	mA
Power dissipation		P_D	400	mW
DC V_{CC} /ground current per supply pin		I_{CC}/I_{GND}	± 100	mA
Storage temperature		T_{stg}	-65 to 150	°C

Note 1: Exceeding any of the absolute maximum ratings, even briefly, lead to deterioration in IC performance or even destruction.

Using continuously under heavy loads (e.g. the application of high temperature/current/voltage and the significant change in temperature, etc.) may cause this product to decrease in the reliability significantly even if the operating conditions (i.e. operating temperature/current/voltage, etc.) are within the absolute maximum ratings and the operating ranges.

Please design the appropriate reliability upon reviewing the Toshiba Semiconductor Reliability Handbook ("Handling Precautions"/"Derating Concept and Methods") and individual reliability data (i.e. reliability test report and estimated failure rate, etc).

Note 2: OFF state

Note 3: High or low state. I_{OUT} absolute maximum rating must be observed.

Note 4: $V_{OUT} < GND$, $V_{OUT} > V_{CC}$

Operating Ranges (Note 1) (Note 2)

Characteristics		Symbol	Rating	Unit
Power supply voltage		V _{CC}	1.8 to 3.6	V
			1.2 to 3.6 (Note 3)	
Input voltage	(\overline{OEAB} , \overline{OEBA} , \overline{LEAB} , \overline{LEBA} , \overline{CEAB} , \overline{CEBA})	V _{IN}	-0.3 to 3.6	V
	(An, Bn)		0 to V _{CC} (Note 4)	
Output voltage	(An, Bn)	V _{OUT}	0 to V _{CC} (Note 5)	V
Output current		I _{OH} /I _{OL}	±24 (Note 6)	mA
			±18 (Note 7)	
			±6 (Note 8)	
Operating temperature		T _{opr}	-40 to 85	°C
Input rise and fall time		dt/dv	0 to 10 (Note 9)	ns/V

Note 1: The operating ranges must be maintained to ensure the normal operation of the device.
Unused inputs must be tied to either V_{CC} or GND.

Note 2: Floating or unused control inputs must be held high or low.

Note 3: Data retention only

Note 4: OFF state

Note 5: High or low state

Note 6: V_{CC} = 3.0 to 3.6 V

Note 7: V_{CC} = 2.3 to 2.7 V

Note 8: V_{CC} = 1.8 V

Note 9: V_{IN} = 0.8 to 2.0 V, V_{CC} = 3.0 V

Electrical Characteristics

DC Characteristics (Ta = -40 to 85°C, 2.7 V < VCC ≤ 3.6 V)

Characteristics		Symbol	Test Condition		VCC (V)	Min	Max	Unit
Input voltage	H-level	V _{IH}	—		2.7 to 3.6	2.0	—	V
	L-level	V _{IL}	—		2.7 to 3.6	—	0.8	
Output voltage	H-level	V _{OH}	V _{IN} = V _{IH} or V _{IL}	I _{OH} = -100 μA	2.7 to 3.6	V _{CC} - 0.2	—	V
				I _{OH} = -12 mA	2.7	2.2	—	
				I _{OH} = -18 mA	3.0	2.4	—	
				I _{OH} = -24 mA	3.0	2.2	—	
	L-level	V _{OL}	V _{IN} = V _{IH} or V _{IL}	I _{OL} = 100 μA	2.7 to 3.6	—	0.2	
				I _{OL} = 12 mA	2.7	—	0.4	
				I _{OL} = 18 mA	3.0	—	0.4	
				I _{OL} = 24 mA	3.0	—	0.55	
Input leakage current (\overline{OEAB} , \overline{OEBA} , \overline{LEAB} , \overline{LEBA} , \overline{CEAB} , \overline{CEBA})		I _{IN}	V _{IN} = 0 to 3.6 V		2.7 to 3.6	—	±5.0	μA
Bushold input minimum drive hold current		I _I (HOLD)	V _{IN} = 0.8 V		3.0	75	—	μA
			V _{IN} = 2.0 V		3.0	-75	—	
Bushold input over-drive current to change state		I _I (OD)	(Note 1)		3.6	—	450	μA
			(Note 2)		3.6	—	-450	
3-state output OFF state current		I _{OZ}	V _{IN} = V _{IH} or V _{IL} V _{OUT} = V _{CC} or GND		2.7 to 3.6	—	±10.0	μA
Quiescent supply current		I _{CC}	V _{IN} = V _{CC} or GND		2.7 to 3.6	—	20.0	μA
Increase in I _{CC} per input		ΔI _{CC}	V _{IH} = V _{CC} - 0.6 V		2.7 to 3.6	—	750	μA

Note 1: An external driver must source at least the specified current to switch from LOW-to-HIGH.

Note 2: An external driver must sink at least the specified current to switch from HIGH-to-LOW.

DC Characteristics (Ta = -40 to 85°C, 2.3 V ≤ VCC ≤ 2.7 V)

Characteristics		Symbol	Test Condition		VCC (V)	Min	Max	Unit
Input voltage	H-level	V _{IH}	—		2.3 to 2.7	1.6	—	V
	L-level	V _{IL}	—		2.3 to 2.7	—	0.7	
Output voltage	H-level	V _{OH}	V _{IN} = V _{IH} or V _{IL}	I _{OH} = -100 μA	2.3 to 2.7	V _{CC} - 0.2	—	V
				I _{OH} = -6 mA	2.3	2.0	—	
				I _{OH} = -12 mA	2.3	1.8	—	
	L-level	V _{OL}	V _{IN} = V _{IH} or V _{IL}	I _{OL} = 100 μA	2.3 to 2.7	—	0.2	
				I _{OL} = 12 mA	2.3	—	0.4	
				I _{OL} = 18 mA	2.3	—	0.6	
Input leakage current (\overline{OEAB} , \overline{OEBA} , \overline{LEAB} , \overline{LEBA} , \overline{CEAB} , \overline{CEBA})		I _{IN}	V _{IN} = 0 to 3.6 V		2.3 to 2.7	—	±5.0	μA
Bushold input minimum drive hold current		I _I (HOLD)	V _{IN} = 0.7 V		2.3	45	—	μA
			V _{IN} = 1.6 V		2.3	-45	—	
Bushold input over-drive current to change state		I _I (OD)	(Note 1)		2.7	—	300	μA
			(Note 2)		2.7	—	-300	
3-state output OFF state current		I _{OZ}	V _{IN} = V _{IH} or V _{IL} V _{OUT} = V _{CC} or GND		2.3 to 2.7	—	±10.0	μA
Quiescent supply current		I _{CC}	V _{IN} = V _{CC} or GND		2.3 to 2.7	—	20.0	μA

Note 1: An external driver must source at least the specified current to switch from LOW-to-HIGH.

Note 2: An external driver must sink at least the specified current to switch from HIGH-to-LOW.

DC Characteristics (Ta = -40 to 85°C, 1.8 V ≤ VCC < 2.3 V)

Characteristics		Symbol	Test Condition		VCC (V)	Min	Max	Unit
Input voltage	H-level	V _{IH}	—		1.8 to 2.3	0.7 × V _{CC}	—	V
	L-level	V _{IL}	—		1.8 to 2.3	—	0.2 × V _{CC}	
Output voltage	H-level	V _{OH}	V _{IN} = V _{IH} or V _{IL}	I _{OH} = -100 μA	1.8	V _{CC} - 0.2	—	V
				I _{OH} = -6 mA	1.8	1.4	—	
	L-level	V _{OL}	V _{IN} = V _{IH} or V _{IL}	I _{OL} = 100 μA	1.8	—	0.2	
				I _{OL} = 6 mA	1.8	—	0.3	
Input leakage current (\overline{OEAB} , \overline{OEBA} , \overline{LEAB} , \overline{LEBA} , \overline{CEAB} , \overline{CEBA})		I _{IN}	V _{IN} = 0 to 3.6 V		1.8	—	±5.0	μA
Bushold input minimum drive hold current		I _{I (HOLD)}	V _{IN} = 0.36 V		1.8	25	—	μA
			V _{IN} = 1.26 V		1.8	-25	—	
Bushold input over-drive current to change state		I _{I (OD)}	(Note 1)		1.8	—	200	μA
			(Note 2)		1.8	—	-200	
3-state output OFF state current		I _{OZ}	V _{IN} = V _{IH} or V _{IL} V _{OUT} = V _{CC} or GND		1.8	—	±10.0	μA
Quiescent supply current		I _{CC}	V _{IN} = V _{CC} or GND		1.8	—	20.0	μA

Note 1: An external driver must source at least the specified current to switch from LOW-to-HIGH.

Note 2: An external driver must sink at least the specified current to switch from HIGH-to-LOW.

AC Characteristics (Ta = -40 to 85°C, input: tr = tf = 2.0 ns, CL = 30 pF, RL = 500 Ω) (Note 1)

Characteristics	Symbol	Test Condition	VCC (V)	Min	Max	Unit
Propagation delay time (An, Bn-Bn, An)	t _{pLH} t _{pHL}	Figure 1, Figure 2	1.8	1.5	8.0	ns
			2.5 ± 0.2	0.8	4.0	
			3.3 ± 0.3	0.6	3.5	
Propagation delay time (LEAB, LEBA-Bn, An)	t _{pLH} t _{pHL}	Figure 1, Figure 2	1.8	1.5	9.8	ns
			2.5 ± 0.2	0.8	5.0	
			3.3 ± 0.3	0.6	3.9	
3-state output enable time (OEAB, OEBA, CEAB, CEBA)	t _{pZL} t _{pZH}	Figure 1, Figure 4	1.8	1.5	9.8	ns
			2.5 ± 0.2	0.8	4.9	
			3.3 ± 0.3	0.6	3.8	
3-state output disable time (OEAB, OEBA, CEAB, CEBA)	t _{pLZ} t _{pHZ}	Figure 1, Figure 4	1.8	1.5	7.6	ns
			2.5 ± 0.2	0.8	4.2	
			3.3 ± 0.3	0.6	3.7	
Minimum pulse width (LEAB, LEBA, CEAB, CEBA)	t _{w(L)}	Figure 1, Figure 2, Figure 3	1.8	4.0	—	ns
			2.5 ± 0.2	1.5	—	
			3.3 ± 0.3	1.5	—	
Minimum setup time (An, Bn-LE, CE)	t _s	Figure 1, Figure 2, Figure 3	1.8	2.5	—	ns
			2.5 ± 0.2	1.5	—	
			3.3 ± 0.3	1.5	—	
Minimum hold time (An, Bn-LE, CE)	t _h	Figure 1, Figure 2, Figure 3	1.8	1.0	—	ns
			2.5 ± 0.2	1.0	—	
			3.3 ± 0.3	1.0	—	
Output to output skew	t _{osLH} t _{osHL}	(Note 2)	1.8	—	0.5	ns
			2.5 ± 0.2	—	0.5	
			3.3 ± 0.3	—	0.5	

Note 1: For C_L = 50 pF, add approximately 300 ps to the AC maximum specification.

Note 2: Parameter guaranteed by design.

(t_{osLH} = |t_{pLHm} - t_{pLHn}|, t_{osHL} = |t_{pHLm} - t_{pHLn}|)

Dynamic Switching Characteristics

($T_a = 25^\circ\text{C}$, input: $t_r = t_f = 2.0 \text{ ns}$, $C_L = 30 \text{ pF}$, $R_L = 500 \Omega$)

Characteristics	Symbol	Test Condition	V _{CC} (V)	Typ.	Unit
Quiet output maximum dynamic V _{OL}	V _{OLP}	V _{IH} = 1.8 V, V _{IL} = 0 V (Note)	1.8	0.25	V
		V _{IH} = 2.5 V, V _{IL} = 0 V (Note)	2.5	0.6	
		V _{IH} = 3.3 V, V _{IL} = 0 V (Note)	3.3	0.8	
Quiet output minimum dynamic V _{OL}	V _{OLV}	V _{IH} = 1.8 V, V _{IL} = 0 V (Note)	1.8	-0.25	V
		V _{IH} = 2.5 V, V _{IL} = 0 V (Note)	2.5	-0.6	
		V _{IH} = 3.3 V, V _{IL} = 0 V (Note)	3.3	-0.8	
Quiet output minimum dynamic V _{OH}	V _{OHV}	V _{IH} = 1.8 V, V _{IL} = 0 V (Note)	1.8	1.5	V
		V _{IH} = 2.5 V, V _{IL} = 0 V (Note)	2.5	1.9	
		V _{IH} = 3.3 V, V _{IL} = 0 V (Note)	3.3	2.2	

Note: Parameter guaranteed by design.

Capacitive Characteristics ($T_a = 25^\circ\text{C}$)

Characteristics	Symbol	Test Condition	V _{CC} (V)	Typ.	Unit
Input capacitance	C _{IN}	—	1.8, 2.5, 3.3	6	pF
Bus I/O capacitance	C _{I/O}		1.8, 2.5, 3.3	7	pF
Power dissipation capacitance	C _{PD}		f _{IN} = 10 MHz (Note)	1.8, 2.5, 3.3	20

Note: C_{PD} is defined as the value of the internal equivalent capacitance which is calculated from the operating current consumption without load.

Average operating current can be obtained by the equation:

$$I_{CC(\text{opr})} = C_{PD} \cdot V_{CC} \cdot f_{IN} + I_{CC}/16 \text{ (per bit)}$$

AC Test Circuit

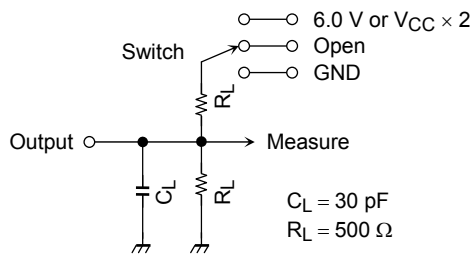

Parameter	Switch
t_{pLH} , t_{pHL}	Open
t_{pLZ} , t_{pZL}	6.0 V $V_{CC} \times 2$ @ $V_{CC} = 3.3 \pm 0.3 \text{ V}$ @ $V_{CC} = 2.5 \pm 0.2 \text{ V}$ @ $V_{CC} = 1.8 \text{ V}$
t_{pHZ} , t_{pZH}	GND

Figure 1

AC Waveform

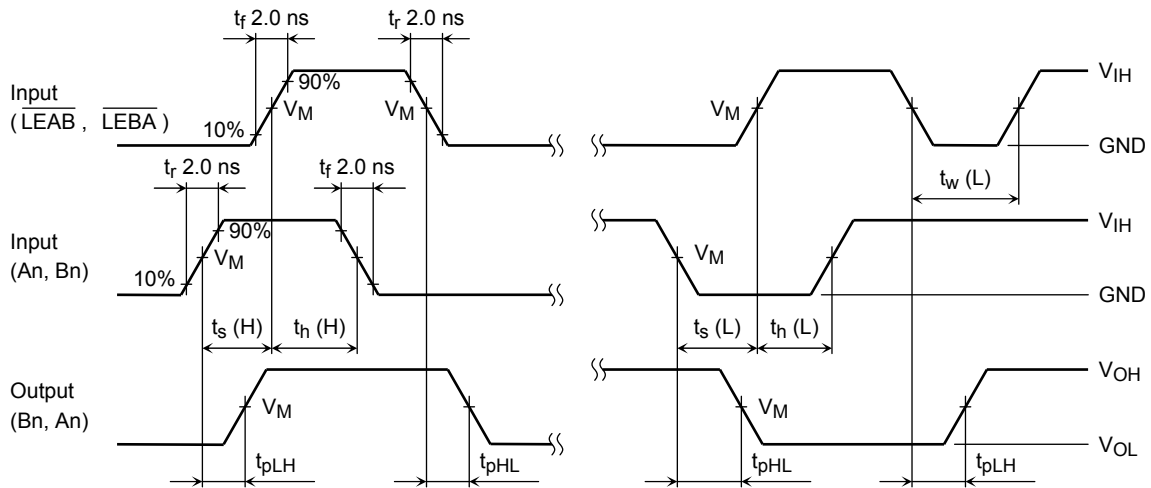

Figure 2 t_{pLH} , t_{pHL} , t_w , t_s , t_h

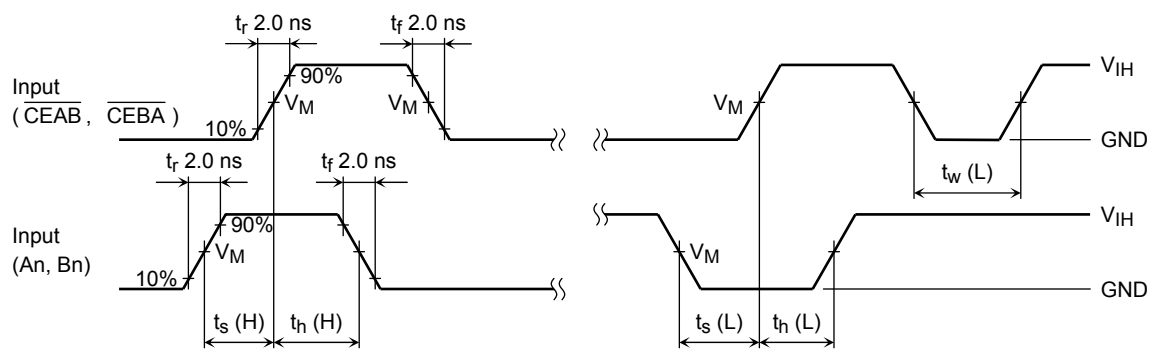

Figure 3 t_w , t_s , t_h

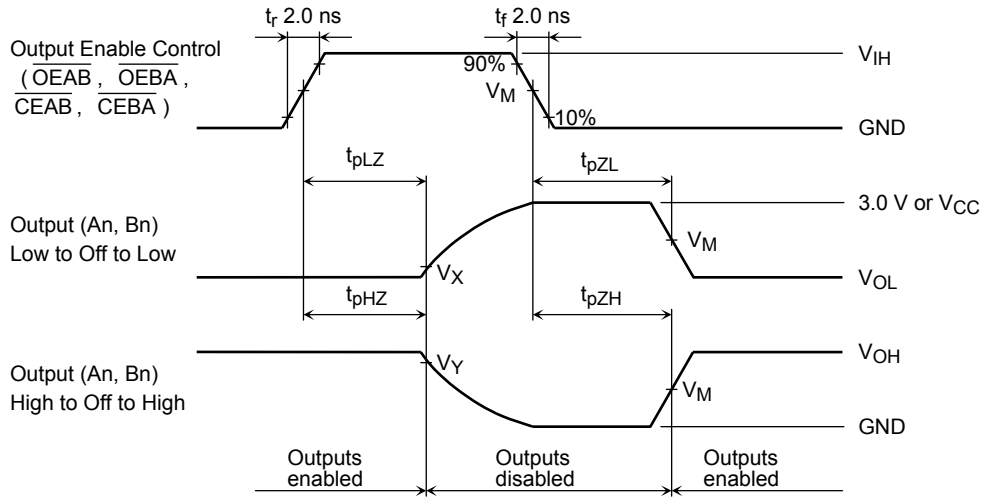

Figure 4 t_{pLZ} , t_{pHZ} , t_{pZL} , t_{pZH}

Symbol	V_{CC}		
	$3.3 \pm 0.3 \text{ V}$	$2.5 \pm 0.2 \text{ V}$	1.8 V
V_{IH}	2.7 V	V_{CC}	V_{CC}
V_M	1.5 V	$V_{CC}/2$	$V_{CC}/2$
V_X	$V_{OL} + 0.3 \text{ V}$	$V_{OL} + 0.15 \text{ V}$	$V_{OL} + 0.15 \text{ V}$
V_Y	$V_{OH} - 0.3 \text{ V}$	$V_{OH} - 0.15 \text{ V}$	$V_{OH} - 0.15 \text{ V}$

Package Dimensions

TSSOP56-P-0061-0.50A

Unit: mm

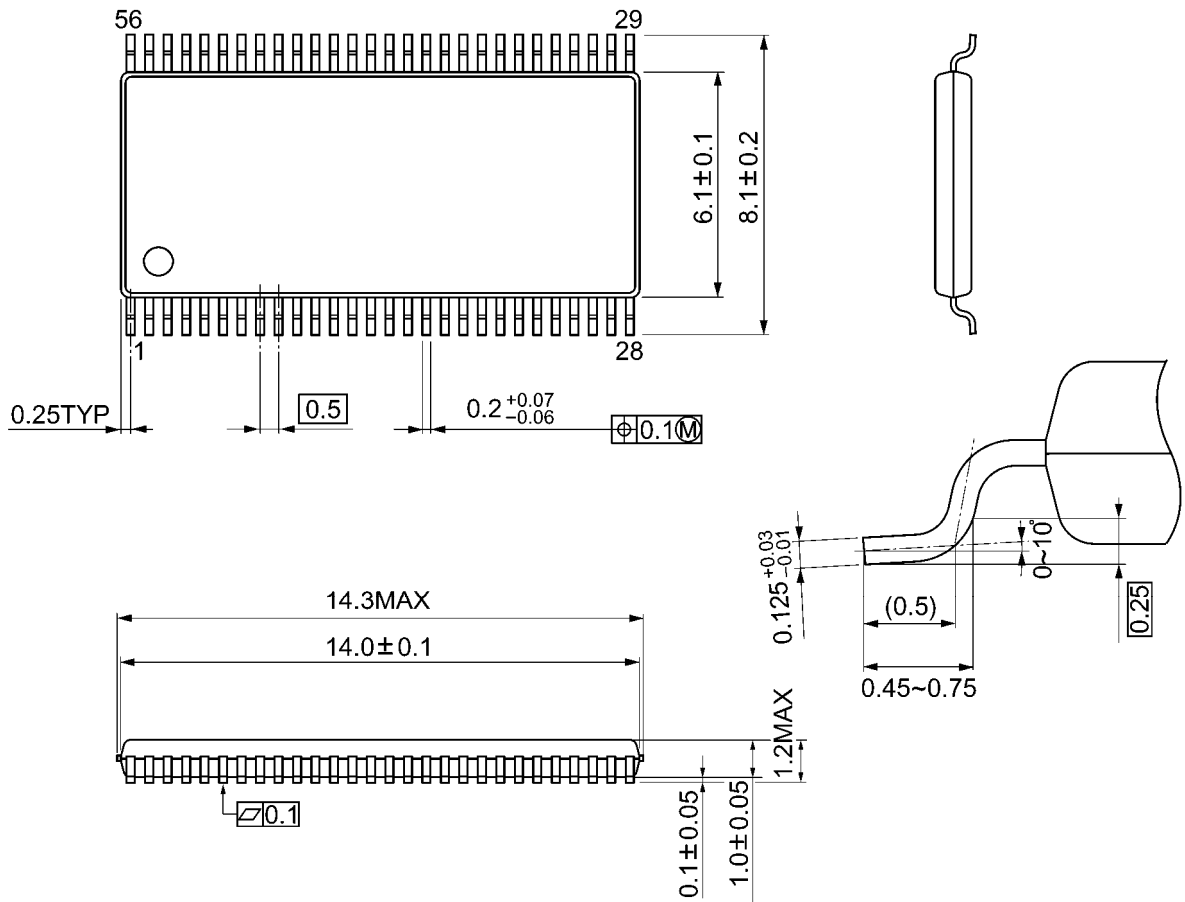

Weight: 0.25 g (typ.)

RESTRICTIONS ON PRODUCT USE

20070701-EN GENERAL

- The information contained herein is subject to change without notice.
- TOSHIBA is continually working to improve the quality and reliability of its products. Nevertheless, semiconductor devices in general can malfunction or fail due to their inherent electrical sensitivity and vulnerability to physical stress. It is the responsibility of the buyer, when utilizing TOSHIBA products, to comply with the standards of safety in making a safe design for the entire system, and to avoid situations in which a malfunction or failure of such TOSHIBA products could cause loss of human life, bodily injury or damage to property.
In developing your designs, please ensure that TOSHIBA products are used within specified operating ranges as set forth in the most recent TOSHIBA products specifications. Also, please keep in mind the precautions and conditions set forth in the "Handling Guide for Semiconductor Devices," or "TOSHIBA Semiconductor Reliability Handbook" etc.
- The TOSHIBA products listed in this document are intended for usage in general electronics applications (computer, personal equipment, office equipment, measuring equipment, industrial robotics, domestic appliances, etc.). These TOSHIBA products are neither intended nor warranted for usage in equipment that requires extraordinarily high quality and/or reliability or a malfunction or failure of which may cause loss of human life or bodily injury ("Unintended Usage"). Unintended Usage include atomic energy control instruments, airplane or spaceship instruments, transportation instruments, traffic signal instruments, combustion control instruments, medical instruments, all types of safety devices, etc.. Unintended Usage of TOSHIBA products listed in this document shall be made at the customer's own risk.
- The products described in this document shall not be used or embedded to any downstream products of which manufacture, use and/or sale are prohibited under any applicable laws and regulations.
- The information contained herein is presented only as a guide for the applications of our products. No responsibility is assumed by TOSHIBA for any infringements of patents or other rights of the third parties which may result from its use. No license is granted by implication or otherwise under any patents or other rights of TOSHIBA or the third parties.
- Please contact your sales representative for product-by-product details in this document regarding RoHS compatibility. Please use these products in this document in compliance with all applicable laws and regulations that regulate the inclusion or use of controlled substances. Toshiba assumes no liability for damage or losses occurring as a result of noncompliance with applicable laws and regulations.