

Low-voltage operation photo IC S4810, S6289

Operation at low voltage from 2.2 V

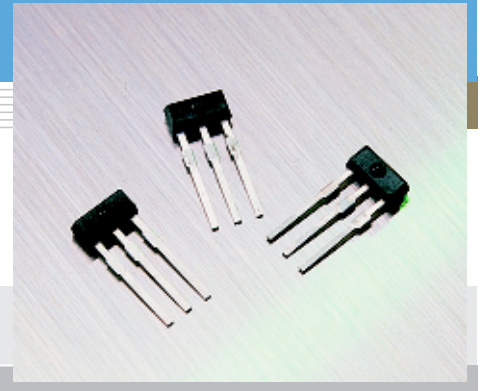

S4810 and S6289 are digital output photo ICs consisting of a photodiode, schmitt trigger circuit and output transistor, all integrated on a single chip and molded into a visible-cut, subminiature plastic package.

Features

- Low-voltage operation: 2.2 to 7 V
- Subminiature plastic package with lens
- Low current consumption
- Open collector output
- S4810: "H" level output at light input
S6289: "L" level output at light input

Applications

- Cameras
- Tape start/end mark sensor for VTRs, cassette tape recorders, etc.
- Optical switches
- Encoders

■ Absolute maximum ratings (Ta=25 °C)

Parameter	Symbol	Value	Unit
Supply voltage	Vcc	-0.5 to +7	V
Output voltage	Vo	-0.5 to +7	V
Output current	Io	8	mA
Power dissipation	P	150	mW
Operating temperature	Topr	-25 to +85	°C
Storage temperature	Tstg	-40 to +100	°C
Soldering	-	260 °C, 3 s, at least 2.5 mm away from package surface	-

■ Electrical and optical characteristics (Ta=25 °C, Vcc=5 V, light source: λp=890 nm LED, unless otherwise noted)

Parameter	Symbol	Condition	S4810			S6289			Unit
			Min.	Typ.	Max.	Min.	Typ.	Max.	
Supply voltage	Vcc		2.2	-	7.0	2.2	-	7.0	V
Low level output voltage	VoL	IoL=4 mA *1	-	-	0.4	-	-	0.4	V
High level output current	IoH	Vo=5 V *2	-	-	10	-	-	10	μA
Current consumption	Icc		-	1.3	3	-	1.3	3	mA
L→H Threshold illuminance	ELH	RL=1.2 kΩ	-	-	1.5	-	-	-	μW/mm ²
H→L Threshold illuminance	EHL	RL=1.2 kΩ	-	-	-	-	-	1.5	μW/mm ²
Hysteresis	-	*3	-	0.9	-	-	0.85	-	-
L→H Propagation delay time	tPLH	2 μW/mm ² RL=1.2 kΩ	-	-	10	-	-	15	μs
H→L Propagation delay time	tPHL		-	-	15	-	-	10	μs
Rise time	tr		-	0.07	-	-	0.07	-	μs
Fall time	tf		-	0.03	-	-	0.03	-	μs
Peak sensitivity wavelength	λp		-	850	-	-	850	-	nm

*1: S4810: E (illuminance) =0 μW/mm², S6289: E=2 μW/mm²

*2: S4810: E=2 μW/mm², S6289: E=0 μW/mm²

*3: S4810: EHL/ELH, S6289: ELH/EHL

Note) Connect a 0.01 μF capacitor or larger between Vcc and GND.

■ Response time measurement circuit

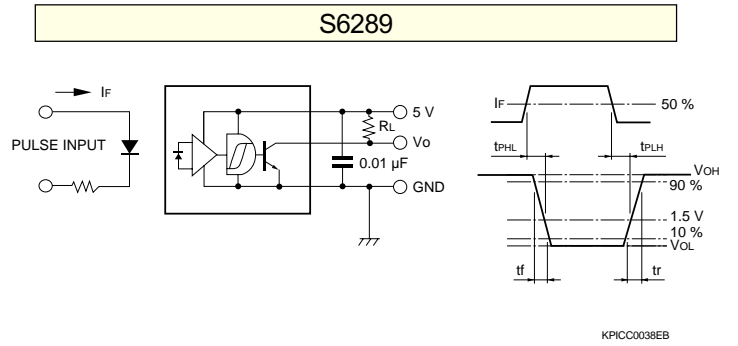
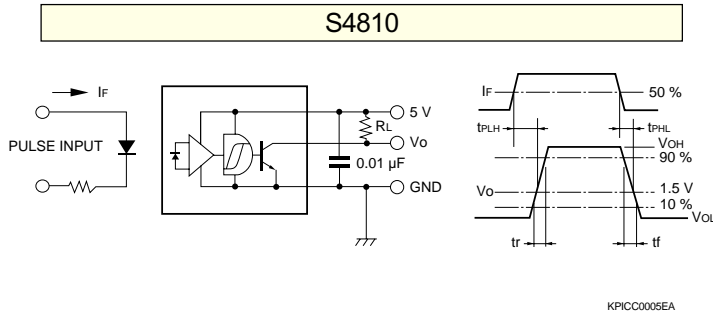

■ Spectral response

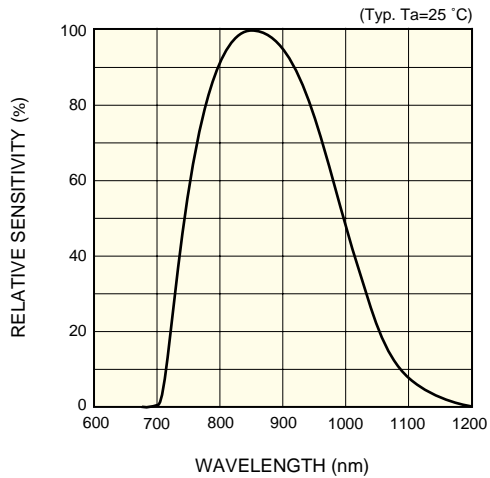

■ Low level output voltage vs. low level output current

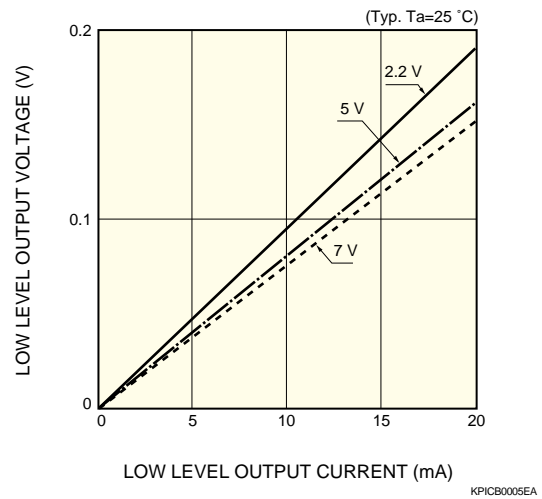

■ Threshold illuminance vs. supply voltage

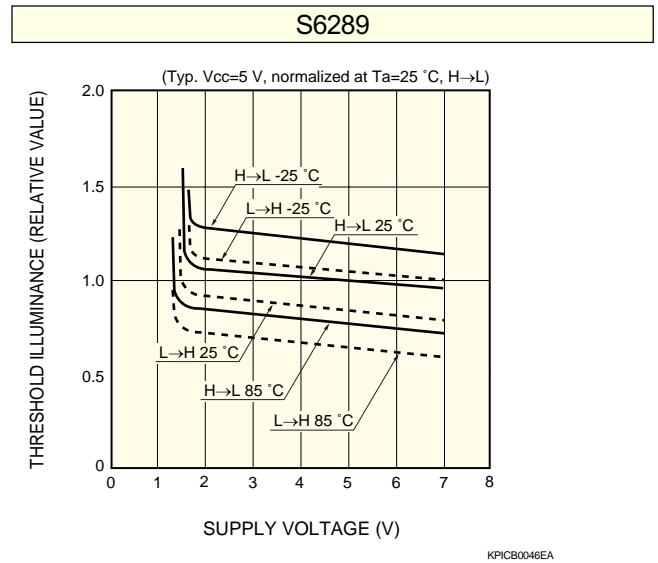
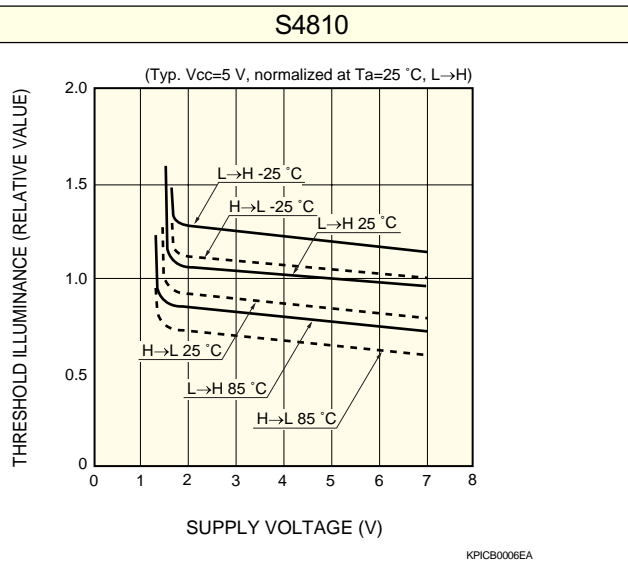

Supply current vs. ambient temperature

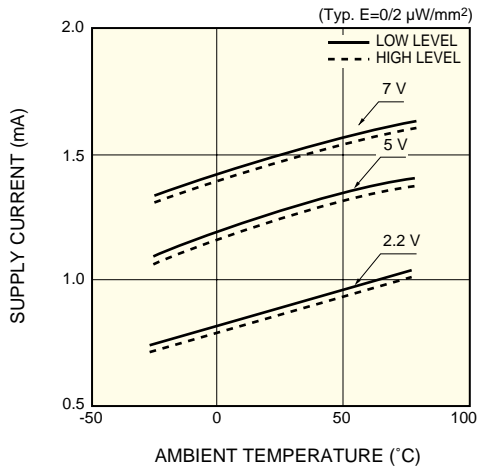

Low level output voltage vs. ambient temperature

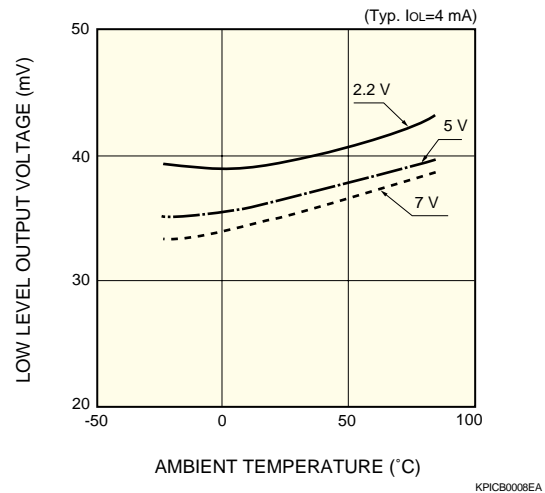

Threshold illuminance vs. ambient temperature

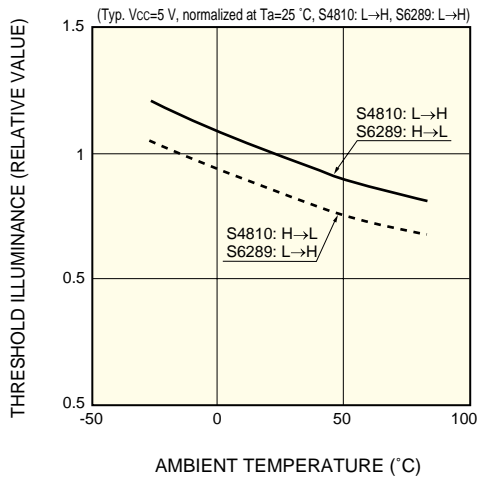

Propagation delay time vs. input light strength

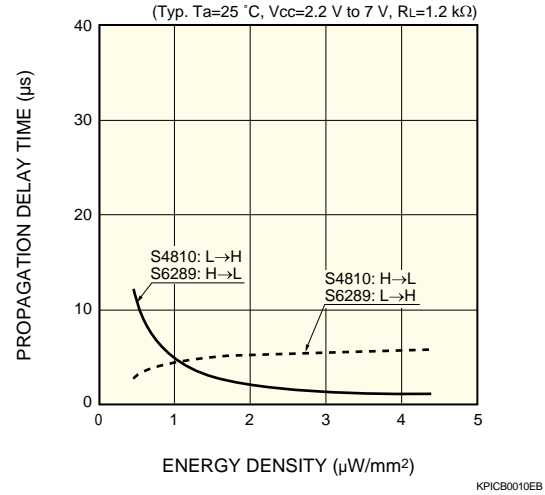

Rise/fall time vs. load resistance

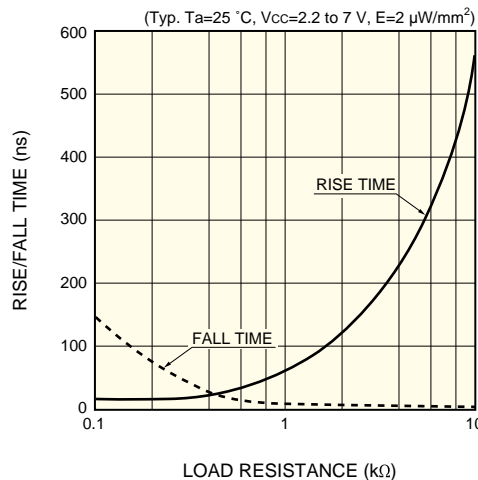

Directivity

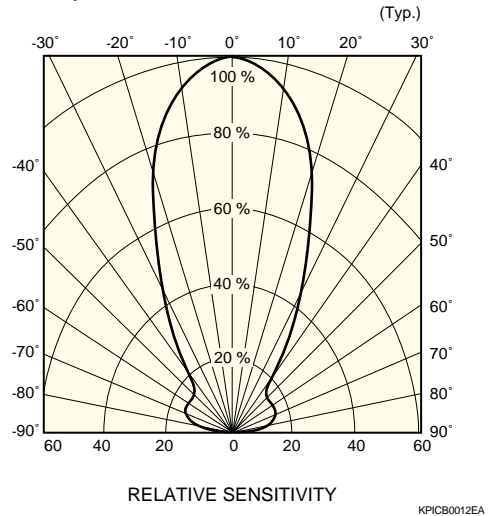

■ Power dissipation vs. ambient temperature

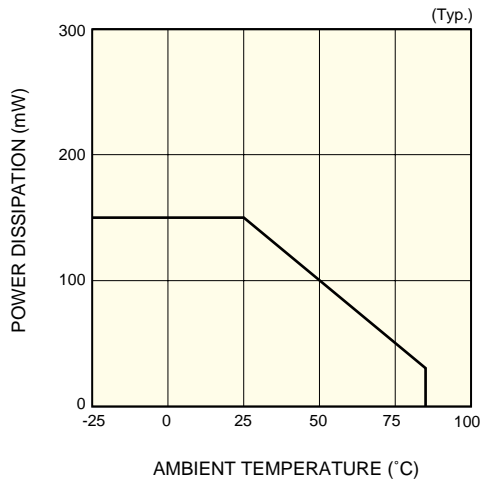

KPICB0048EA

■ Dimensional outline (unit: mm)

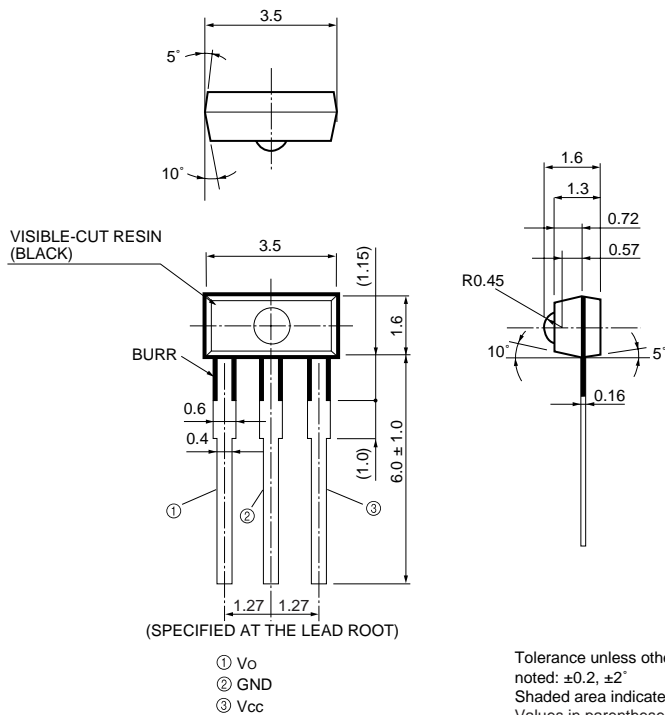

KPICA0005EB

HAMAMATSU

Information furnished by HAMAMATSU is believed to be reliable. However, no responsibility is assumed for possible inaccuracies or omissions. Specifications are subject to change without notice. No patent rights are granted to any of the circuits described herein. Type numbers of products listed in the specification sheets or supplied as samples may have a suffix "(X)" which means tentative specifications or a suffix "(Z)" which means developmental specifications. ©2009 Hamamatsu Photonics K.K.

HAMAMATSU PHOTONICS K.K., Solid State Division

1126-1 Ichino-cho, Higashi-ku, Hamamatsu City, 435-8558 Japan, Telephone: (81) 53-434-3311, Fax: (81) 53-434-5184, www.hamamatsu.com

U.S.A.: Hamamatsu Corporation: 360 Foothill Road, P.O.Box 6910, Bridgewater, N.J. 08807-0910, U.S.A., Telephone: (1) 908-231-0960, Fax: (1) 908-231-1218

Germany: Hamamatsu Photonics Deutschland GmbH: Arzbergerstr. 10, D-82211 Herrsching am Ammersee, Germany, Telephone: (49) 8152-375-0, Fax: (49) 8152-265-8

France: Hamamatsu Photonics France S.A.R.L.: 19, Rue du Saule Trapu, Parc du Moulin de Massy, 91882 Massy Cedex, France, Telephone: 33-(1) 69 53 71 00, Fax: 33-(1) 69 53 71 10

United Kingdom: Hamamatsu Photonics UK Limited: 2 Howard Court, 10 Tewin Road, Welwyn Garden City, Hertfordshire AL7 1BW, United Kingdom, Telephone: (44) 1707-294888, Fax: (44) 1707-325777

North Europe: Hamamatsu Photonics Norden AB: Smidesvägen 12, SE-171 41 Solna, Sweden, Telephone: (46) 8-509-031-00, Fax: (46) 8-509-031-01

Italy: Hamamatsu Photonics Italia S.R.L.: Strada della Moia, 1/E, 20020 Arese, (Milano), Italy, Telephone: (39) 02-935-81-733, Fax: (39) 02-935-81-741

Cat. No. KPIC1005E06
Aug. 2009 DN