

PAD	CONNECTION
1	Enable/Disable
2	Ground
3	Output
4	Supply

Features

- ▣ Supply voltages from 2.5V ~ 3.3V
- ▣ Low power consumption
- ▣ Enable / disable tristate function
- ▣ Low phase noise and jitter
- ▣ Excellent frequency stability

Enable / Disable Function

Input (pad 1)	Output (pad 3)
Open	Enabled
'1' level	Enabled
'0' level	High Impedance

Specifications

GTXO-C25J: 2.5V supply

GTXO-C25K: 2.8V supply

GTXO-C25L: 3.3V supply

Parameters	Variant			Option Codes
	J	K	L	
Frequency range: 4.0 ~ 54.0MHz	■	■	■	
Calibration tolerance: ±0.5ppm @ +25°C ±2°C	■	■	■	
Temperature stability: ±3.0ppm ±2.5ppm	□	□	□	K J
Temperature range: 0 to +50°C -10 to +60°C -20 to +70°C -30 to +75°C -40 to +85°C	□	□	□	R C N S I
Storage temperature range: -40 to +125°C	■	■	■	
Ageing: ±1.0ppm max first year	■	■	■	
Supply voltage (V _{DD}): +2.5V (±5%) +2.8V (±5%) +3.3V (±5%)	■	■	■	
Supply current (mA): 4.0 ~ 10MHz >10.0 ~ 20.0MHz >20.0 ~ 30.0MHz >30.0 ~ 40.0MHz >40.0 ~ 54.0MHz	3.1 3.7 4.2 4.6 5.5	3.4 4.1 4.7 5.2 6.0	4.0 4.8 5.5 6.0 7.0	
Frequency vs supply voltage: ±0.2ppm, V _{DD} ±5%	■	■	■	
Driving ability: 15pF CMOS	■	■	■	
Logic levels: '0' level = 10%V _{DD} max '1' level = 90%V _{DD} min	■	■	■	
Waveform symmetry: 45:55 @ 50%V _{DD}	■	■	■	
Rise / fall time: 5ns max	■	■	■	
Frequency vs load: ±0.2ppm, Z _L ±10%	■	■	■	
Enable / disable function: Tristate (control via pad 1)	■	■	■	
Standby current: 10µA max	■	■	■	
Phase noise (typ): -145dBc/Hz @ 10kHz	■	■	■	
Period jitter RMS: 3ps typ	■	■	■	

■ Standard. □ Optional - Please specify required code(s) when ordering

Ordering Information

Product name + variant + option codes + frequency
 Option codes must be included to properly specify a model.
 eg: **GTXO-C25L/JS 24.00MHz** 3.3V supply, ±2.5ppm -30+75°C
GTXO-C25K/KN 40.00MHz 2.8V supply, ±3.0ppm -20+70°C
 Option code X (eg GTXO-C25L/X) denotes a custom spec.

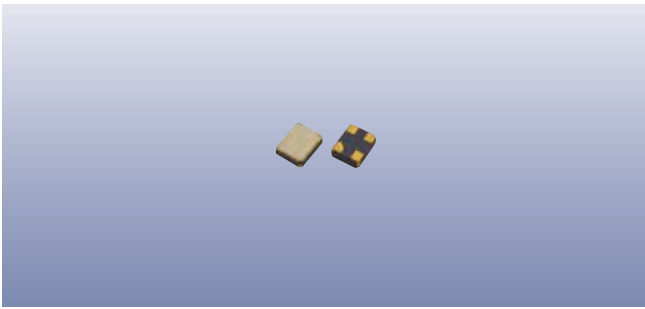

Construction

- ▮ Ceramic body with gold-plated pads
- ▮ Metal lid, seam sealed

Composition



This product is lead-free, and is fully compliant with the RoHS directive 2011/65/EU



Packaging & Handling

Production quantities supplied on T&R, 1k pcs per reel.
Small quantities may be supplied on tape (no reel), or in bulk.



◆ Static sensitive product. Observe proper handling precautions

Marking

S	FREQUENCY
CTO	DC

Marking type: Laser
DC = Date code in YM, eg "AB" = Feb 2011

	A	B	C	D	E	F	G	H	J	K	L	M
Y	1	2	3	4	5	6	7	8	9	0		
M	Jan	Feb	Mar	Apr	May	Jun	Jul	Aug	Sep	Oct	Nov	Dec

Tape & Reel Specification

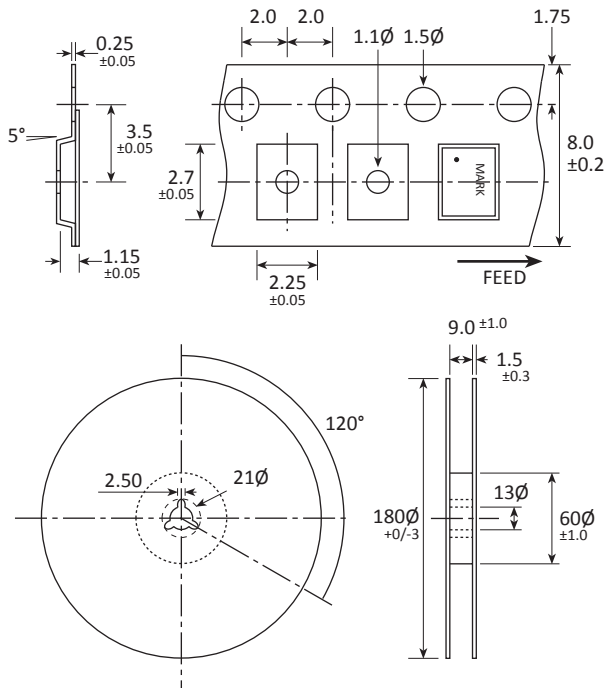

Not to scale. Dimensions in mm. Tolerances ±0.1mm unless otherwise stated

Soldering Profile

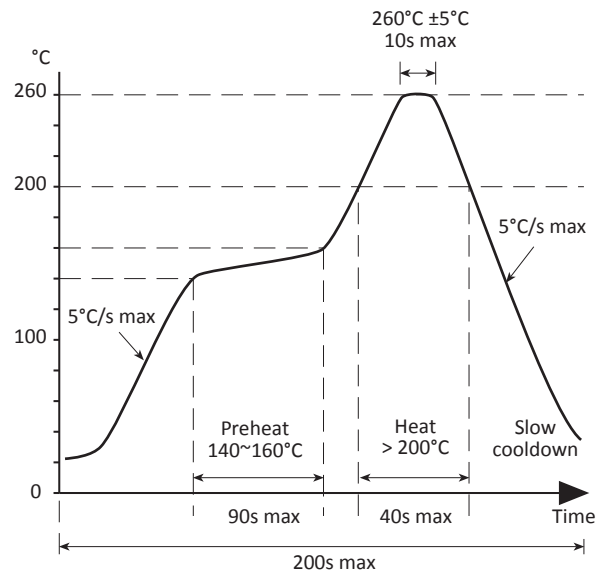

Solder resistance: 260°C x 10 secs x 2.