

DESCRIPTION

The EV3120EJ-00A is a Boost converter evaluation board for the MP3120EJ, a synchronous, 1.1MHz fixed frequency, current mode step-up converter with output to input disconnect.

It can startup from an input voltage as low as 0.8V and provides inrush current limiting as well as output short circuit protection.

The output voltage also can be regulated when $V_{in} > U_o$, and the P-channel MOS is no longer act as a low impedance switch.

The EV3120EJ-00A regulates the output voltage up to 3.3V from single cell AA battery without the uses of an external Schottky diode.

The MP3120EJ is offered in a TSOT23-6 package.

ELECTRICAL SPECIFICATION

Parameter	Symbol	Value	Units
Input Voltage	V_{IN}	0.8-5	V
Output Voltage	V_{OUT}	3.3	V

FEATURES

- Up to 96% Efficiency
- True Output Load Disconnect
- Inrush Current Limiting and Internal Soft-Start
- Low Voltage Start-Up: 0.8V
- Internal Synchronous Rectifier
- Current Mode Control with Internal Compensation
- Short-Circuit Protection
- 1.1MHz Fixed Frequency Switching
- Input Range: 0.8V to 5V
- Output Range: 2.5V to 5V
- Tiny External Components
- Small 6-lead ThinSOT Package

APPLICATION

- Single-cell, Two-cell and Three-cell Alkaline, NiCd or NiMH or single-cell Li Battery Consumer Products
- MP3 Players
- Wireless Mouse
- Audio Recorders

MPS Receivers "Monolithic Power Systems", "MPS", and "The Future of Analog IC Technology" are Registered Trademarks of Monolithic Power Systems, Inc.

EV3120EJ-00A EVALUATION BOARD



Board Number	MPS IC Number
EV3120EJ-00A	MP3120EJ

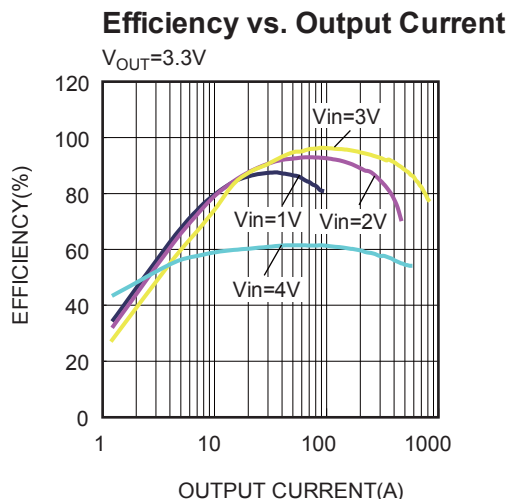

EVALUATION BOARD SCHEMATIC

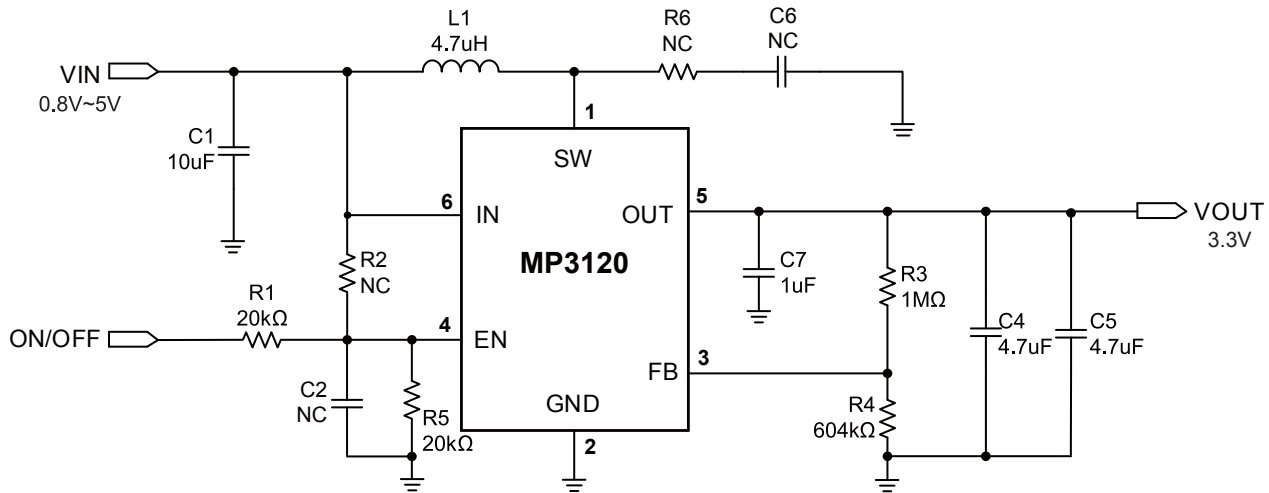

EV3120EJ-00A BILL OF MATERIALS

Qty	Ref	Value	Description	Package	Manufacturer	Manufacturer P/N
1	L1	4.7uH	1.6A inductor	SMD	TDK	SLF6028T-4R7M1R6
1	C1	10uF	Ceramic Capacitor, 25V, X7R	1210	TDK	C3225X5R1E106K
1	C2	NC		0603	TDK	
1	C3	150p	Ceramic Capacitor, 50V, X7R	0603	TDK	C1608X7R1C151K
2	C4, C5	4.7uF	Ceramic Capacitor, 16V, X7R	1206	TDK	C3216X7R1C475K
1	C6	NC				
1	R1	20kΩ	Resistor 5%	0603	Yageo	RC0603JR-0720KL
1	R2	NC				
1	R3	1MΩ	Resistor 1%	0603	Yageo	RC0603FR-071ML
1	R4	604kΩ	Resistor 1%	0603	Yageo	RC0603FR-07604KL
1	R5	20kΩ	Resistor 5%	0603	Yageo	RC0603JR-0720KL
1	R6	NC				

PRINTED CIRCUIT BOARD LAYOUT

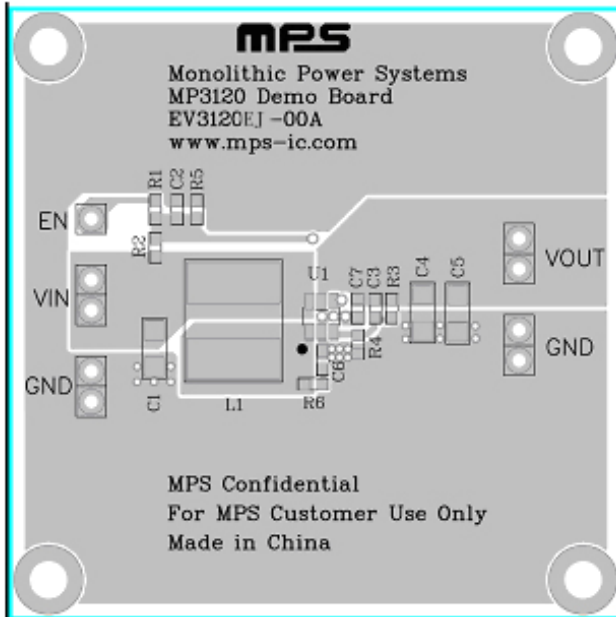

Figure1-Top layer and Top silk

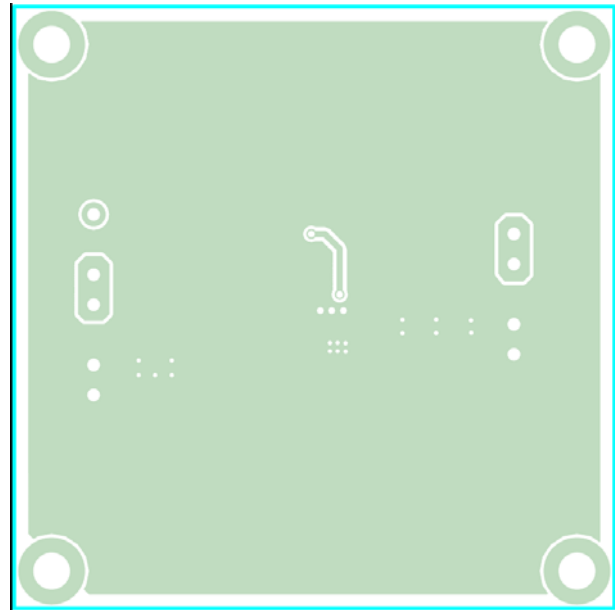

Figure2-Bottom Layer

QUICK START GUIDE

The output voltage of this board is set to 3.3V. The board layout accommodates most commonly used inductors and output capacitors.

1. Preset power supply to $0.8V \leq U_{IN} \leq 5V$;
2. Turn off the power supply;
3. Connect power supply terminals to
Positive(+): IN
Negative(-): GND
4. Connect Load to:
Positive(+): OUT
Negative(-): GND
5. Connect the EN to 5V power supply
Positive(+): EN
Negative(-): GND
6. Turn on the power supply;
7. The output voltage U_{OUT} can be adjusted by changing R3. And the value of R3 can be calculated by the following formula:

$$R3 = R4 \times \left(\frac{U_{OUT} - U_{FB}}{U_{FB}} \right)$$

Where $U_{FB}=1.2V$ and $R4=604k\Omega$

For example, if $U_{OUT}=3.3V$

$$R3 = 604k\Omega \times \left(\frac{3.3 - 1.2}{1.2} \right) = 1057k\Omega$$

Therefore use a 1M Ω resistor.

8. The U_{OUT} in the EVB is set to 3.3V, if other output is need the R3 can be changed.

NOTICE: The information in this document is subject to change without notice. Users should warrant and guarantee that third party Intellectual Property rights are not infringed upon when integrating MPS products into any application. MPS will not assume any legal responsibility for any said applications.