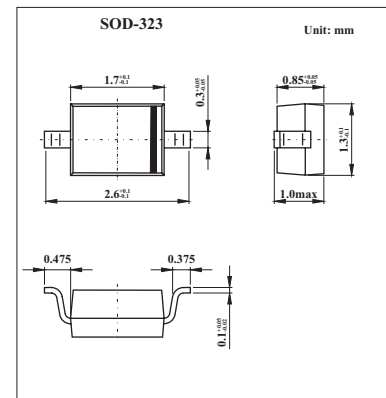

Silicon PIN diode

BAP70-03

■ Features

- High voltage, current controlled RF resistor for attenuators
- Low diode capacitance
- Very low series inductance.

■ Absolute Maximum Ratings $T_a = 25^\circ\text{C}$

Parameter	Symbol	Min	Max	Unit
continuous reverse voltage	V_R		50	V
continuous forward current	I_F		100	mA
total power dissipation $T_s = 90^\circ\text{C}$	P_{tot}		500	mW
storage temperature	T_{stg}	-65	+150	$^\circ\text{C}$
junction temperature	T_j	-65	+150	$^\circ\text{C}$
thermal resistance from junction to soldering point	$R_{th\ j-s}$		120	K/W

■ Electrical Characteristics $T_a = 25^\circ\text{C}$

Parameter	Symbol	Conditions	Typ	Max	Unit
forward voltage	V_F	$I_F = 50\text{ mA}$	0.95	1.1	V
reverse leakage current	I_R	$V_R = 30\text{ V}$		20	nA
diode capacitance	C_d	$V_R = 0; f = 1\text{ MHz}$	570		fF
		$V_R = 1\text{ V}; f = 1\text{ MHz}$	400		
		$V_R = 5\text{ V}; f = 1\text{ MHz}$	270		
		$V_R = 20\text{ V}; f = 1\text{ MHz}$	200	250	
diode forward resistance	r_D	$I_F = 0.5\text{ mA}; f = 100\text{ MHz}$	77	100	Ω
		$I_F = 1\text{ mA}; f = 100\text{ MHz}$	40	50	
		$I_F = 10\text{ mA}; f = 100\text{ MHz}$	5.4	7	
		$I_F = 100\text{ mA}; f = 100\text{ MHz}$	1.4	1.9	
charge carrier life time	τ_L	when switched from $I_F = 10\text{ mA}$ to $I_R = 6\text{ mA}$; $R_L = 100\ \Omega$; measured at $I_R = 3\text{ mA}$	1.25		μs
series inductance	L_s	$I_F = 100\text{ mA}; f = 100\text{ MHz}$	1.5		nH

■ Marking

Marking	A9
---------	----