

MAPX	MODIFICATION	DATE

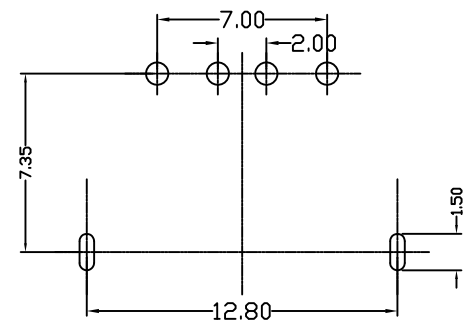
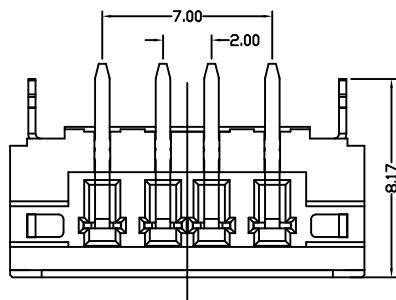
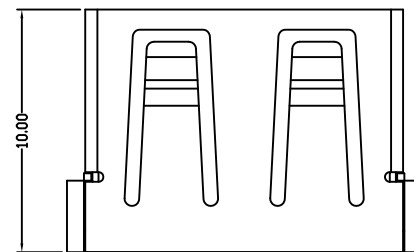
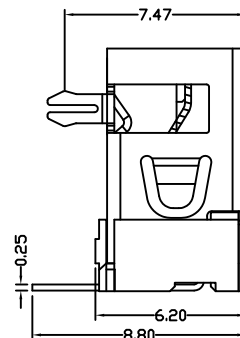
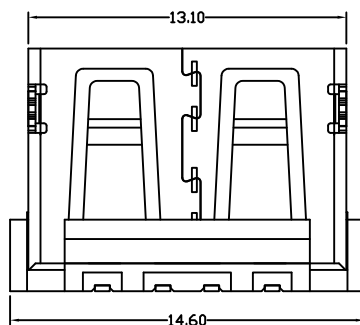
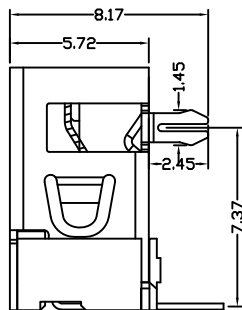
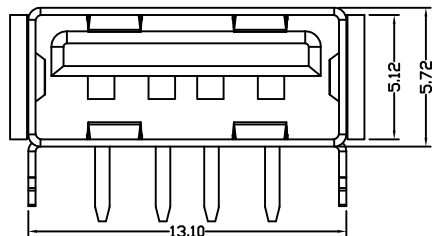

Specification:

1. Electrical Characteristics:

Dielectric Withstanding Voltage: AC 500V/1MINUTE.
 Insulation Resistance: 1000 MΩMin.
 Contact Resistance: 30 mΩ Max.

2. Mechanical Characteristics:

INSERTION FORCE: 30N(3.06Kgf) MAX
 EXTRACTION FORCE: 10~30N(1.02~3.06Kgf)
 Durability:1500cycles.EXTRACTION FORCE:10~30N(1.02~3.06Kgf)

3. Material:

Terminal: Phosphor Bronze, C5191R-H T=0.25
 Plating: Gold 0.76 um Min plating over 1.27 um Min Nickel underplate, 2.54 um Min Sn selective plating on solder tail;
 Shell: Phosphor Bronze, C5191R-H T=0.30mm
 Plating: Nickel underplate 2.54 um Min;
 Housing: 无卤LCP Black; UL94V-0

4. Environmental:

Operating Temperature: 0°C to +85°C.

<p>产品图 PRODUCT CHART DWG</p> <p>公差一览表 TOLERANCE UNLESS OTHERWISE</p> <table border="1"> <tr> <td>X.</td> <td>±0.15</td> <td>X.</td> <td>±5.°</td> </tr> <tr> <td>.X</td> <td>±0.10</td> <td>.X</td> <td>±2.°</td> </tr> <tr> <td>.XX</td> <td>±0.05</td> <td>.XX</td> <td>±1.°</td> </tr> <tr> <td>.XXX</td> <td>±0.03</td> <td>.XXX</td> <td>±0.5°</td> </tr> </table>				X.	±0.15	X.	±5.°	.X	±0.10	.X	±2.°	.XX	±0.05	.XX	±1.°	.XXX	±0.03	.XXX	±0.5°	<p>单位 UNITS</p> <p>比例 SCALE</p> <p>日期 DATE</p>				<p>制图 DRAWING</p> <p>审核 CHKD</p> <p>核准 APPD</p>				<p>Z-Y-B</p> <p>制图料号 PRODUCT PART NO</p> <p>产品名称 PRODUCT NAME</p> <p>角法 VIEW</p>				<p>914-122A1011D10200</p> <p>AF10.0苹果款两脚鱼叉方弹铜壳 PBT白胶偏蓝DIP</p> <p>版本 VER</p> <p>AD</p>			
X.	±0.15	X.	±5.°																																
.X	±0.10	.X	±2.°																																
.XX	±0.05	.XX	±1.°																																
.XXX	±0.03	.XXX	±0.5°																																
<p>深州市精拓金电子有限公司</p>				<p>MM</p>				<p>1:1</p>				<p>2011.09.02</p>				<p>MM</p>				<p>2011.09.02</p>															