

# BAROMETER MODULE

2011-6-8

Version: 1.4

+

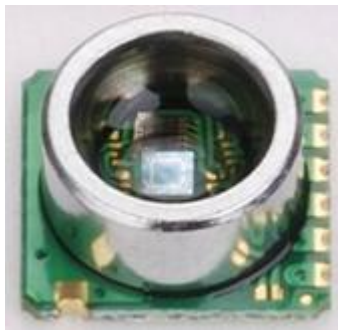

- . Integrated pressure sensor
- . Pressure Range 300-1100hpa
- . 16 Bit  $\Sigma$ - $\Delta$  ADC
- . 5 coefficients for software compensation stored on chip
- . I<sup>2</sup>C Serial Interface
- . One system clock line (32768Hz)
- . One hardware controlled reset line
- . Low voltage, low power

## Description

The HP02S includes a piezo-resistive pressure sensor and an ADC interface. It provides 16 bit word data for pressure and temperature related voltage. With the help of a highly accurate calibration of the sensor, 5 unique coefficients were stored on the chip, thus accurate pressure and temperature reading can be realized. HP02S is a low power, low voltage device with automatic power down switching. I<sup>2</sup>C Serial Interface is used for communications with a microprocessor.

## Features

- . 14 Bit ENOB ADC resolution
- . Supply voltage 2.0v-5.0v
- . 0° C to + 50° C operating range

## Applications

- . Pressure measurement and control systems
- . Mobile altimeter/barometer systems
- . Weather forecast products
- . Adventure or multi-mode watches

## Block Diagram

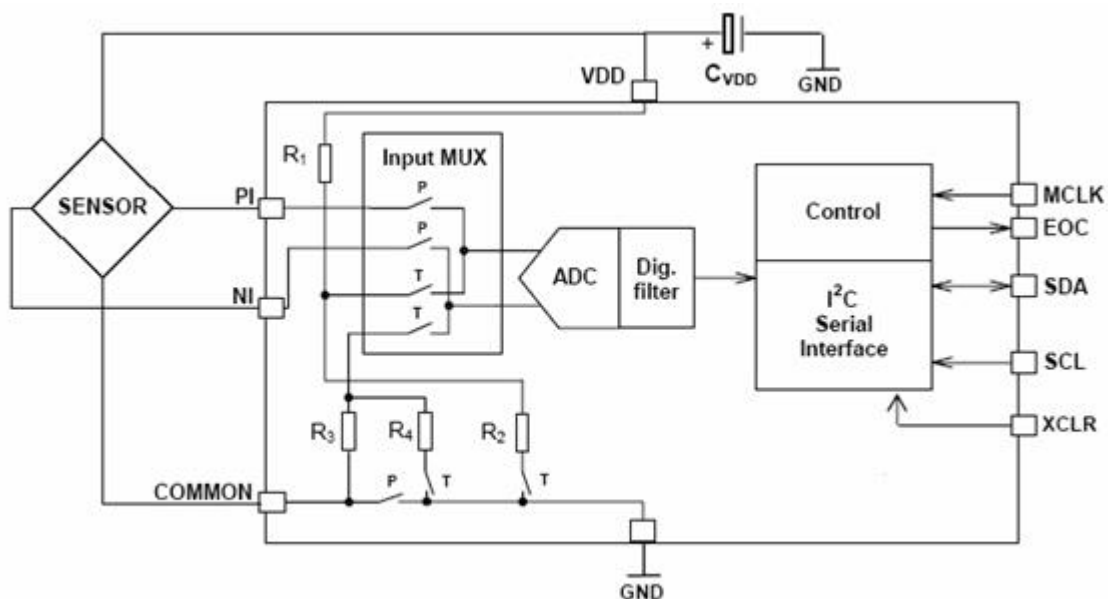

**BAROMETER MODULE**

2011-6-8

Version: 1.4

Pin Name	Pin Number	Type	Function
VSS	1	G	power ground
VDD	2	P	power VCC
MCLK	3	I	master clock(32k) input
XCLR	4	I	ADC reset input (keep low when system is in idle state)
SDA	5	I/O	. I <sup>2</sup> C data input and output
SCL	6	I	I <sup>2</sup> C clock input

\* XCLR is to reset the AD converter (active low). XCLR should be set to high only during AD conversion phase(reading T1,D1). While at all other states, such as reading calibration factors, this pin should be kept low.

**Absolute Maximum Ratings**

Parameter	Symbol	Min	Max	Unit
Supply Voltage	VDD	-0.3	5	V
Over pressure	P		5	Bar(abs)
Storage Temperature	Tstg	-40	125	°C

**Recommended Operating Conditions**

Parameter	Symbol	Conditions	Min	Typ	Max	Unit
Supply Voltage	VDD		2.0	3	5.0	V
Supply Current	I	VDD=3V	0.0001	0.5	2	mA
During Conversion			0.01	0.5	2	mA
stand by	I	VDD=3V	- - -	0.1	3	μA
Operating Pressure Range	P		300		1100	hpa (abs)
Operating Temperature Range	T		0	25	50	°C
Conversion Time	T	MCLK=32k			35	ms
Duty Cycle of MCLK			40%	50%	60%	%
Serial Date Rate	SCL				500	KHZ

**Pressure and Temperature Output Characteristics**

With the calibration data provided by the HP02S system, it should be able to reach the following characteristics:

Parameter	Symbol	Conditions	Min	Typ	Max	Unit
Resolution			0.1			hpa
Absolute Pressure Accuracy		900-1100 @ 10°C-30°C	-5.0		+5.0	hpa
Absolute Pressure Accuracy		900-1100 @ 0°C-10°C 30°C-50°C	-8.0		+8.0	hpa
Long Term Stability		12 month		2		hpa
VDD Dependency		2.0~5.0	-1.5	0	1.5	hpa

**BAROMETER MODULE**

2011-6-8

Version: 1.4

**Pressure and Temperature Measurement**

The main function of HP02S system is to convert the uncompensated pressure and temperature signal from a pressure sensor. After the conversion, the following two values can be obtained:

- . measured temperature      “T1”
- . measured pressure         “D1”

As the sensor is strongly temperature dependent, it is necessary to compensate for these effects. Therefore 5 sensor-specific coefficients are stored on the HP02S at our manufacturing facility, and they allow an accurate software compensation in the application.

The 5 coefficients are:

- . “D0”: Offset of pressure coefficient.
- . “T0”: Offset temperature.
- . “P0”: Offset fine tuning of pressure.
- . “S”: Temperature coefficient of sensitivity.
- . “C”: Constant parameter for each sensor.

**Note: Make sure to pull low XCLR before start to Read these coefficients or the data read out is probably incorrect**

**Pressure and Temperature Calculation:**

Step 1: (calculate offset, sensitivity and final pressure value)

$dUP=D1-D0$
$dUT=(29*(T1-T0)/50-(T1-T0)^2/76666)*S/C$
$P=P0+100*(dUP+dUT)/S$

**Example:**

D0=41058  
T0=32819  
P0=10143  
S=294  
C=320

D1=42920  
T1=29889

$dUP = 42920-41058 =1862$

$dUT=(29*(29889-32819)/50-(29889-32819)^2/76666)*294/320=-1664$

$P=10143+100*(1862-1664)/294=10210=1021.0hpa$

# BAROMETER MODULE

2011-6-8

Version: 1.4

## Serial Interface

The I<sup>2</sup>C interface is used for accessing calibration data as well as reading measurement result from AD conversion.

## Reading Calibration Factor:

The EEPROM chip address is set to 0, and reading or writing of the EEPROM is fully compatible to AT24C02. Bus drive timing should be referred to the specification of this part.

Coefficient	EEPROM ADDRESS(decimal)	Parameter Range(Hex)
D0(MSB:LSB)	(02:03)	0x0100 -- 0xFFFF
T0(MSB:LSB)	(04:05)	0x0100 -- 0xFFFF
P0(MSB:LSB)	(06:07)	0x0100 -- 0xFFFF
S(MSB:LSB)	(08:09)	0x0001 -- 0xFFFF
C(MSB:LSB)	(0A:0B)	0x0001 -- 0xFFFF

## Reading Temperature and Pressure value:T1,D1

AD chip I<sup>2</sup>C address is set to 0xEE (device write address), 0xEF (device read address). In order to get the AD value D1 and T1, you have to follow the following timing sequence:

Pressure Measure(D1):

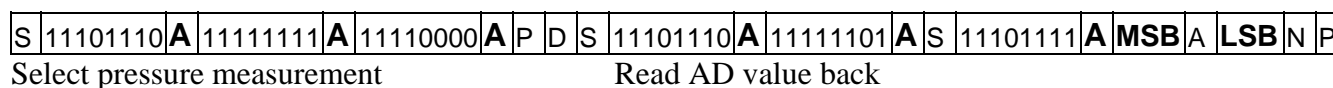

Temperature Measure(T1):

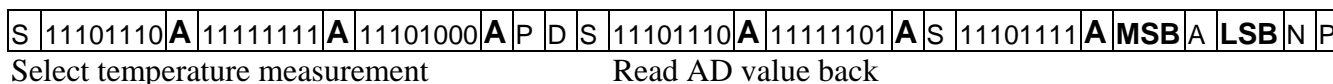

S: I<sup>2</sup>C bus START (refer to AT24C02 EEPROM start command)

P: I<sup>2</sup>C bus STOP (refer to AT24C02 EEPROM stop command)

A (bold): I<sup>2</sup>C bus acknowledge by slave (SDA pull low: slave send out bit 0)

A: I<sup>2</sup>C bus acknowledge by master (SDA pull low: master send out bit 0)

N: I<sup>2</sup>C bus no acknowledge from master (SDA keep high: master send out bit 1 instead)

D : delay for 38ms or above

MSB: conversion result (MSB bit clocked out first)

# BAROMETER MODULE

2011-6-8

Version: 1.4

LSB: conversion result (MSB bit clocked out first).

**Remark:**

Before start an AD conversion cycle, remember to set XCLR pin high so that the system is no longer in the reset state.

All data read from the module is in hex format.

After first power on, the first read data should be disregarded, and only the second value be used. This can assure that unstable reading after power on reset can be filtered out.

For altitude calculation purpose, use averaging scheme to improve the stability of pressure reading, we recommend making at least 8 times averaging so that it is possible to achieve 0.3m accuracy (about 1 foot).

**Typical Application Circuit Diagram:**

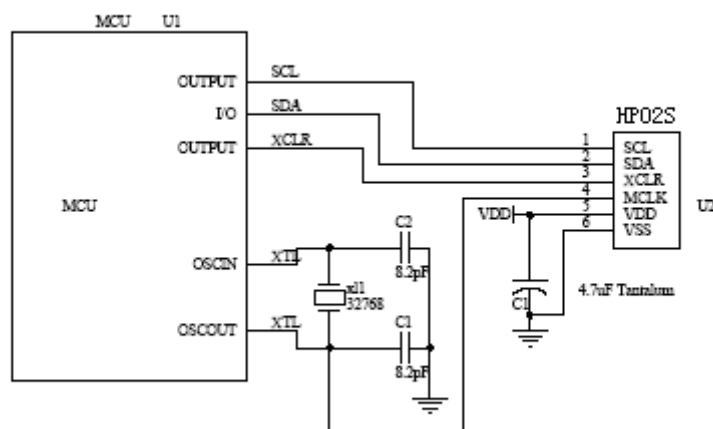

**Remark:**

In the battery supply product this application need be changed as:  
 32 KHz signal is outputted via the port of the MCU instead of the 32.768 KHz crystal to MCLK pin. The MCU will not output 32 KHz signal and keep low level when the HP02S enter to standby mode.

# BAROMETER MODULE

2011-6-8

Version: 1.4

## HP02S Mechanical Dimension

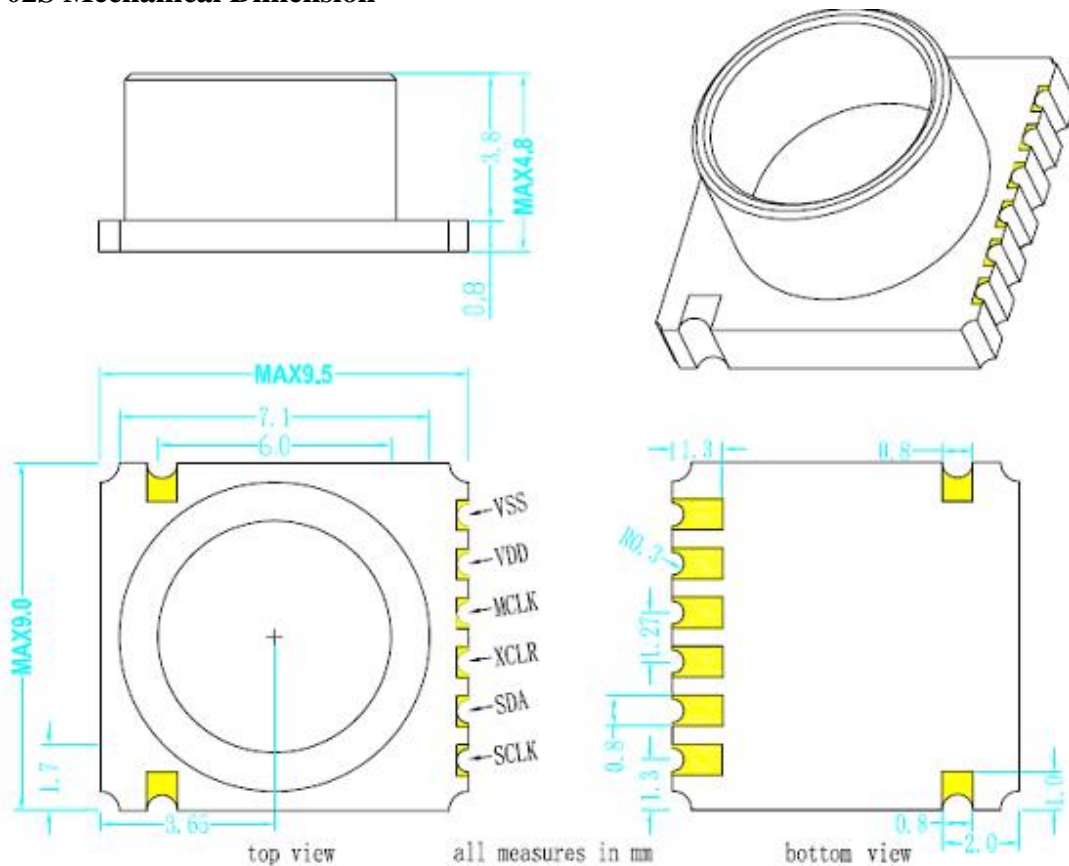

## Important Notices

**Never unplug the module when power is on.**

Do not use this product as safety or emergency stop device or in any application where failure of this product could lead in personal injury. Failure to comply with these instructions could result with death or serious injury.

Should buyer purchase or use HOPE RF products for any such unintended or unauthorized application, buyer should indemnify and hold HOPE RF and its officers, employees, affiliates and distributors harmless against all claims, costs, damages and expenses, and reasonable attorney fees arising out of, directly or indirectly, any claim of personal injury associated with such unintended or unauthorized use, even if such claim alleges that HOPE RF was negligent regarding the design or manufacturing of the part.

Hope RF reserves the right, without further notice, to change the product specification and/or information in this document and to improve reliability, functions and design.