

Standard Products

VRG8657/VRG8658

Dual Voltage Regulator, 1.0 Amp, Positive Low Dropout (LDO), Adjustable Radiation Tolerant

www.aeroflex.com/voltreg

May 15, 2012



AEROFLEX
A passion for performance.

FEATURES

- ❑ Manufactured using  Space Qualified RH1086 die
- ❑ Radiation performance
 - Total dose \geq 100 krad (Si)
- ❑ Two-Independent voltage regulators
- ❑ Thermal shutdown
- ❑ Output voltage adjustable: 1.25V to 23V
- ❑ Dropout voltage: 1.3V at 1.0Amp
- ❑ 3-Terminal
- ❑ Output current: 1.0Amp
- ❑ Voltage reference: 1.25V +2%, -3.2%
- ❑ Load regulation: 0.3% max
- ❑ Line regulation: 0.25% max
- ❑ Ripple rejection: >60dB
- ❑ Packaging – Hermetic metal
 - Thru-hole or Surface mount
 - 6 Leads, .655"L x .415"W x .200"Ht
 - Power package
 - Weight - 5 gm max
- ❑ Designed for aerospace and high reliability space applications
- ❑ Aeroflex Plainview's Radiation Hardness Assurance Plan is DLA Certified to MIL-PRF-38534, Appendix G.

DESCRIPTION

The Aeroflex Plainview VRG8657/8658 consists of two Positive Adjustable (RH1086) LDO voltage regulators each capable of supplying 1.0Amps over the output voltage range as defined under recommended operating conditions. The VRG8657/8658 offers excellent line and load regulation specifications and ripple rejection. There is full electrical isolation between the regulators and each regulator to the package.

The VRG8657/8658 serves a wide variety of applications including SCSI-2 Active Terminator, High Efficiency Linear Regulators, Post Regulators for Switching Supplies, Constant Current Regulators, Battery Chargers and Microprocessor Supply.

The VRG8657/8658 has been specifically designed to meet exposure to radiation environments. The VRG8657 is configured for a Thru-Hole 6 lead metal power package and the VRG8658 is configured for a Surface Mount 6 lead metal power package. It is guaranteed operational from -55°C to +125°C. Available screened to MIL-STD-883, the VRG8657/8658 is ideal for demanding military and space applications.

Dropout ($V_{IN} - V_{OUT}$) decreases at lower load currents for both regulators.

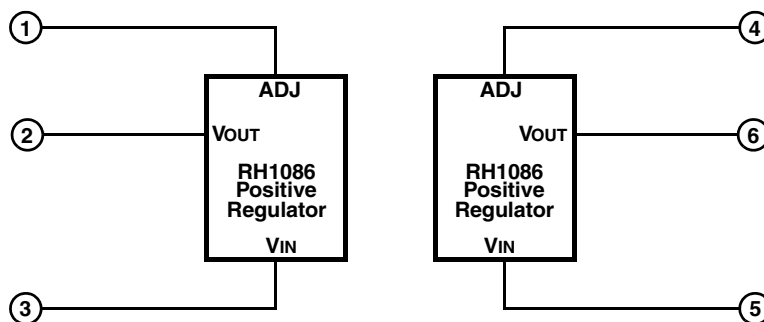

FIGURE 1 – BLOCK DIAGRAM / SCHEMATIC

ABSOLUTE MAXIMUM RATINGS

PARAMETER	RANGE	UNITS
Input Voltage	25+VREF	VDC
Lead temperature (soldering 10 Sec)	300	°C
Input Output Differential	25	VDC
Output Voltage	+25	VDC
DC Output Current	1.5	A
ESD (MIL-STD-883, M3015, Class 3A)	>4000	V
Operating Junction Temperature Range	-55 to +150	°C
Storage Temperature Range	-65 to +150	°C

NOTICE: Stresses above those listed under "Absolute Maximums Rating" may cause permanent damage to the device. These are stress rating only; functional operation beyond the "Operation Conditions" is not recommended and extended exposure beyond the "Operation Conditions" may effect device reliability.

RECOMMENDED OPERATING CONDITIONS

PARAMETER	RANGE	UNITS
Output Voltage Range	1.275 to 23	VDC
Input Output Differential <u>3/</u>	1.5 to 25	VDC
Case Operating Temperature Range	-55 to +125	°C
Thermal Resistance, Junction to case θ_{JC}	5	°C/W

ELECTRICAL PERFORMANCE CHARACTERISTICS

Unless otherwise specified, $-55^{\circ}\text{C} \leq T_c \leq +125^{\circ}\text{C}$

PARAMETER	SYM	CONDITIONS ($P \leq P_{MAX}$)	MIN	MAX	UNITS
Reference Voltage <u>2/ 3/</u>	VREF	$1.5V \leq V_{IN} - V_{OUT} \leq 15V, 10mA \leq I_{OUT} \leq 1.0A$	1.210	1.275	V
Line Regulation <u>2/ 3/</u>	$\frac{\Delta V_{OUT}}{\Delta V_{IN}}$	$I_{LOAD} = 10mA, 1.5V \leq V_{IN} - V_{OUT} \leq 15V$	-	0.25	%
Load Regulation <u>2/ 3/</u>	$\frac{\Delta V_{OUT}}{\Delta I_{OUT}}$	$10mA \leq I_{OUT} \leq 1.0A, V_{IN} - V_{OUT} = 3V$	-	0.3	%
Dropout Voltage <u>2/ 4/</u>	VDROP	$\Delta V_{REF} = 1\%, I_{OUT} = 1.0A$	-	1.30	V
Adjust Pin Current <u>2/</u>	-		-	120	μA
Adjust Pin Current Change <u>2/</u>	-	$10 mA \leq I_{OUT} \leq 1A, 1.5V \leq V_{IN} - V_{OUT} \leq 15V$	-	5	μA
Current Limit <u>2/ 6/</u>	IMAX	$V_{IN} - V_{OUT} = 5V$ $V_{IN} - V_{OUT} \leq 25V$	1.5 0.047	- -	A A
Minimum Load Current <u>5/</u>	IMIN	$V_{IN} - V_{OUT} = 25V$	-	10	mA
Ripple Rejection <u>3/</u>	-	$I_{OUT} = 1.0A, V_{IN} - V_{OUT} = 3V, f = 120Hz,$ $C_{ADJ} = C_{OUT} = 25\mu F$	60	-	dB
Thermal Regulation	-	30ms pulse, $T_c = +25^{\circ}\text{C}$	-	0.04	%/W
VREF Long-Term Stability <u>5/</u>	-	Burn In: $T_c = +125^{\circ}\text{C} @ 1000hrs$ minimum, tested @ 25°C	-	0.3	%

Notes:

1/ For compliance with MIL-STD- 883 revision C current density specification, the RH1086MK is derated to 1 Amp but is capable of 1.5 Amps.

3/ Line and load regulation are guaranteed up to the maximum power dissipation of 15W. Power dissipation is determined by the input/output differential voltage and the output current. Guaranteed maximum power dissipation will not be available over the full input/output voltage range.

4/ Dropout voltage is specified over the full output current range of the device.

5/ Not tested. Shall be guaranteed by design, characterization, or correlation to other tested parameters.

6/ Pulsed @ <10% duty cycle @ +25°C (See Note 1).

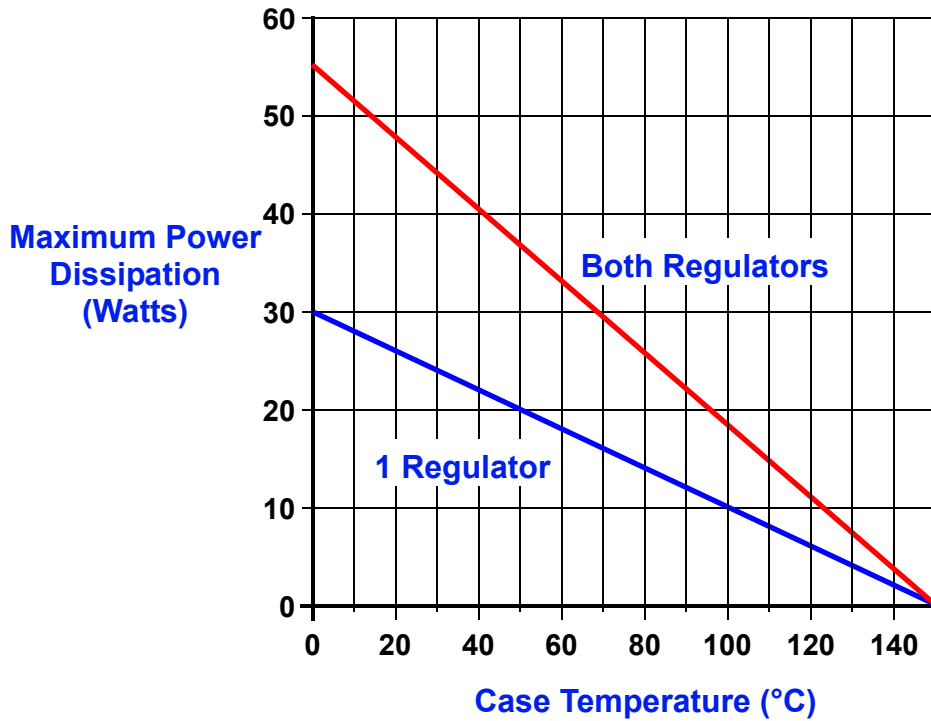

FIGURE 2 – MAXIMUM POWER vs CASE TEMPERATURE

The maximum Power dissipation is limited by the thermal shutdown function of each regulator chip in the VG8657/8658. The graph above represents the achievable power before the chip shuts down. The first line in the graph represents the maximum power dissipation of the VG8657/8658 with one regulator on (the other off) and the other line represents both regulators on dissipating equal power. If both regulators are on and one regulator is dissipating more power than the other, the maximum power dissipation of the VG8657/8658 will fall between the two lines. This graph is based on the maximum junction temperature of 150°C and a thermal resistance (Θ_{JC}) of 5°C/W.

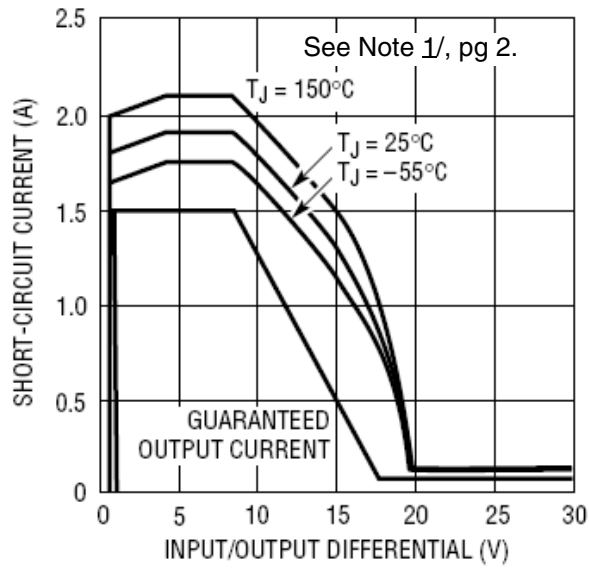

FIGURE 3 – RH1086 SHORT CIRCUIT CURRENT

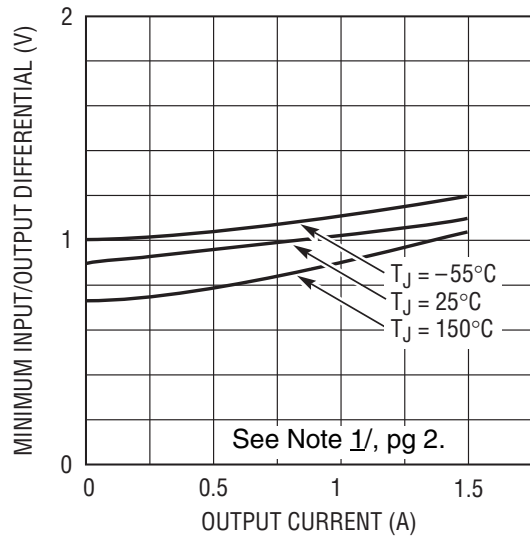

FIGURE 4 – RH1086 DROPOUT VOLTAGE TYPICAL CURVE

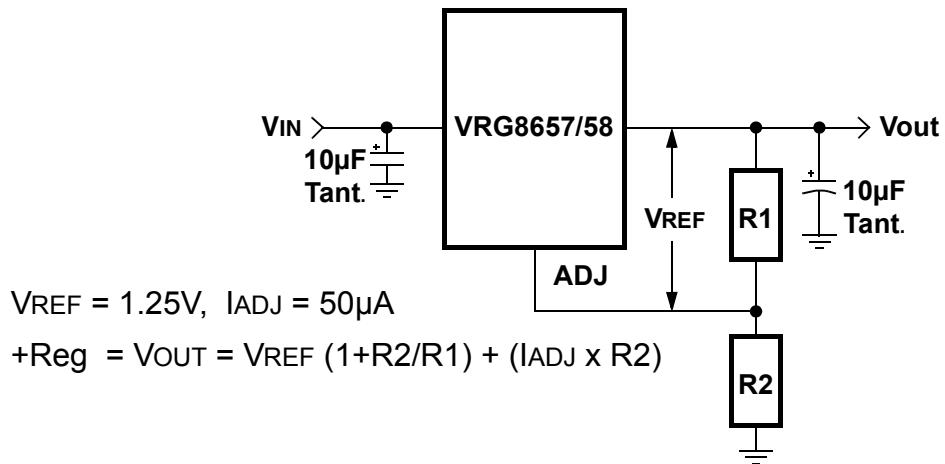
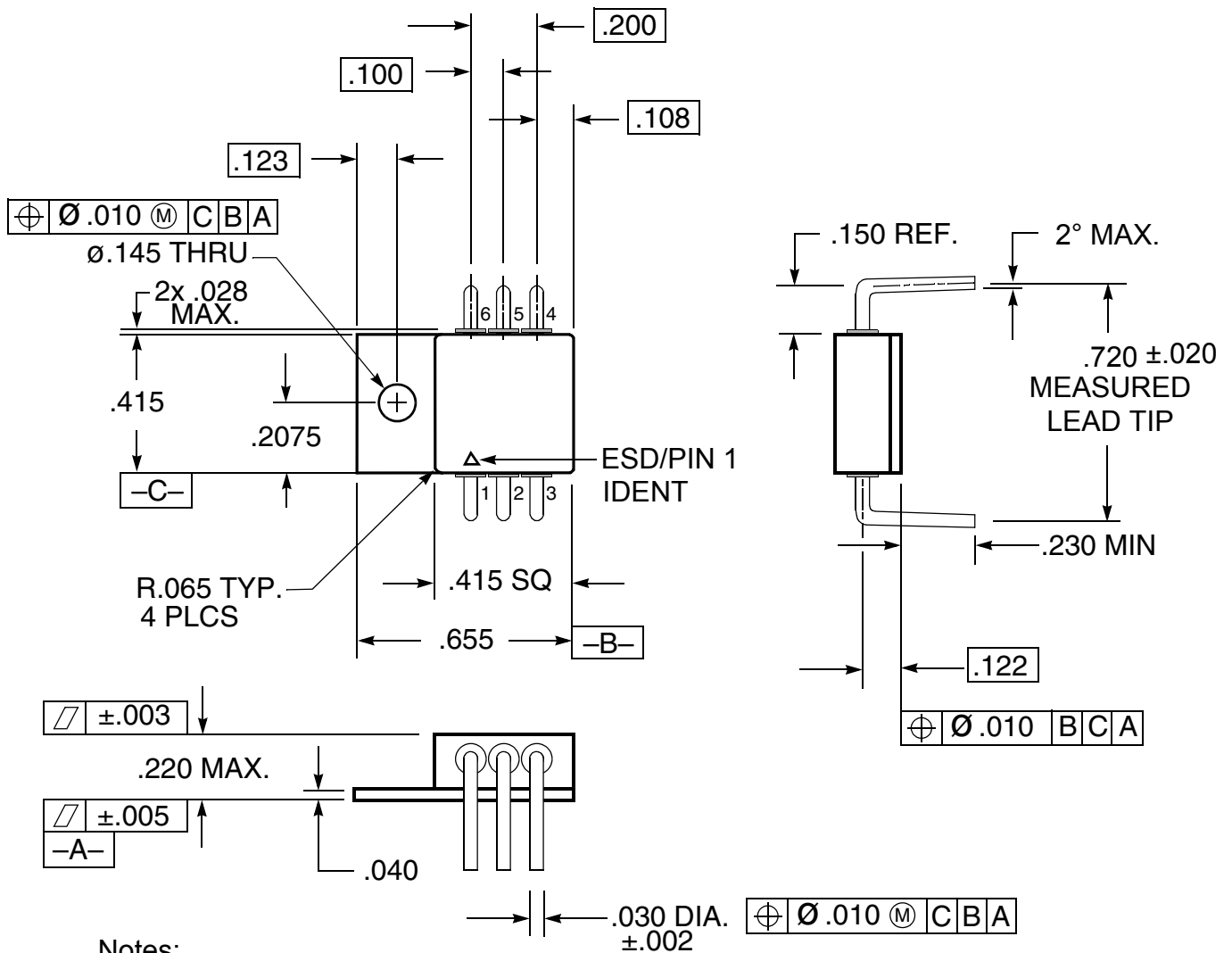

FIGURE 5 – BASIC RH1086 ADJUSTABLE REGULATOR APPLICATION

TABLE I – PIN NUMBERS vs FUNCTION

PIN	FUNCTION
1	POS_ADJ_1
2	POS_VOUT_1
3	POS_VIN_1
4	POS_ADJ_2
5	POS_VIN_2
6	POS_VOUT_2



Notes:

1. Dimension Tolerance: $\pm .005$ inches
2. Package contains BeO substrate
3. Case electrically isolated

FIGURE 6 – PACKAGE OUTLINE — THRU-HOLE POWER PACKAGE

TABLE II – PIN NUMBERS vs FUNCTION

PIN	FUNCTION
1	POS_ADJ_1
2	POS_VOUT_1
3	POS_VIN_1
4	POS_ADJ_2
5	POS_VIN_2
6	POS_VOUT_2

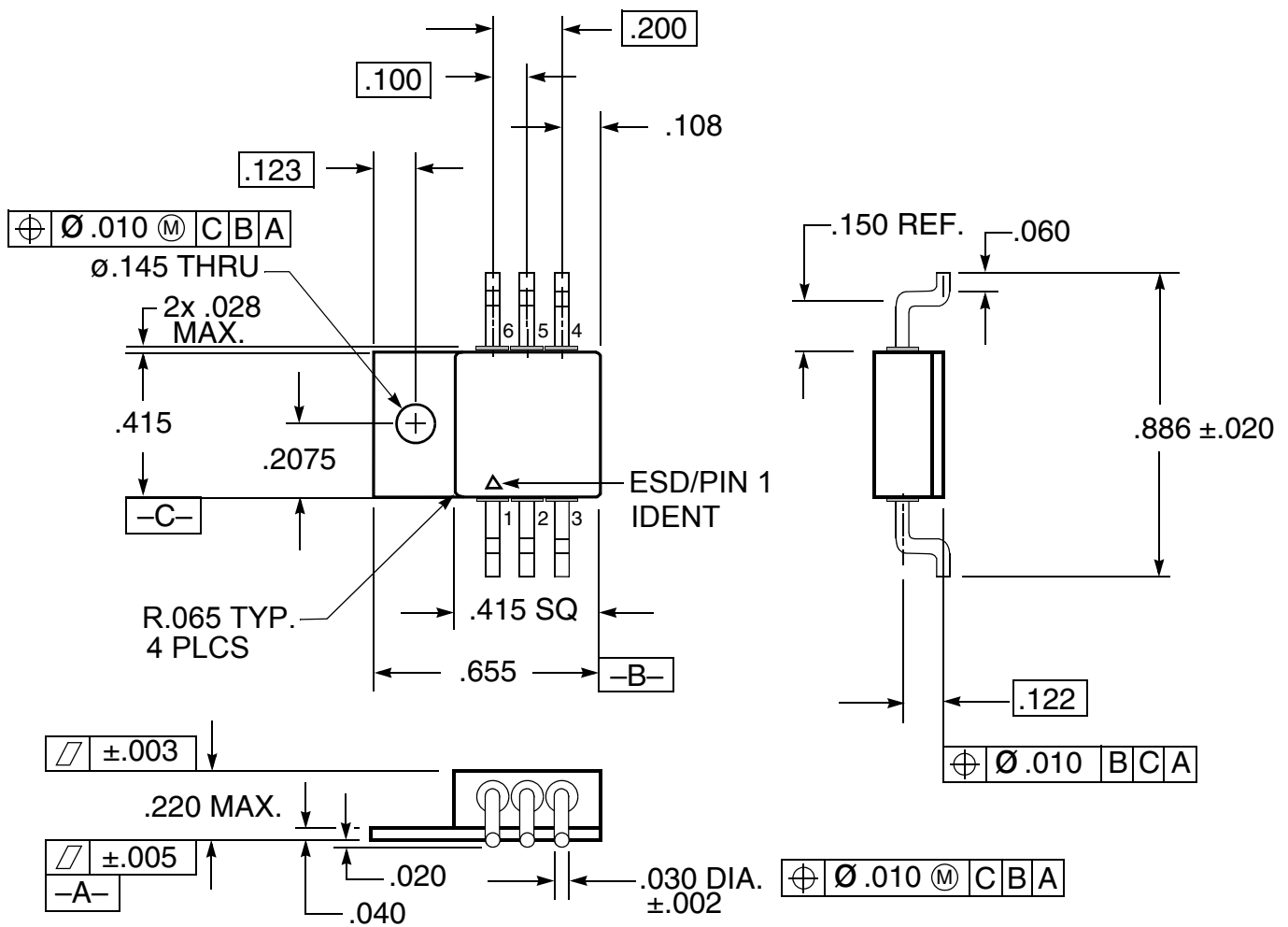

Notes:

1. Dimension Tolerance: $\pm .005$ inches
2. Package contains BeO substrate
3. Case electrically isolated

FIGURE 7 – PACKAGE OUTLINE — SURFACE MOUNT POWER PACKAGE

ORDERING INFORMATION

MODEL	DLA SMD #	SCREENING	PACKAGE
VRG8657-7	-	Commercial Flow, +25°C testing only	6 Lead Thru-Hole Power Pkg
VRG8657-S	-	Military Temperature, -55°C to +125°C Screened in accordance with the individual Test Methods of MIL-STD-883 for Space Applications	
VRG8657-201-1S	5962-0920102KXC	In accordance with DLA SMD	
VRG8657-201-2S	5962-0920102KXA		
VRG8657-901-1S	5962R0920102KXC	In accordance with DLA Certified RHA Program Plan to RHA Level "R", 100krads(Si)	
VRG8657-901-2S	5962R0920102KXA		
VRG8658-7	-	Commercial Flow, +25°C testing only	6 Lead Surface Mount Power Pkg
VRG8658-S	-	Military Temperature, -55°C to +125°C Screened in accordance with the individual Test Methods of MIL-STD-883 for Space Applications	
VRG8658-201-1S	5962-0920102KYC	In accordance with DLA SMD	
VRG8658-201-2S	5962-0920102KYA		
VRG8658-901-1S	5962R0920102KYC	In accordance with DLA Certified RHA Program Plan to RHA Level "R", 100krads(Si)	
VRG8658-901-2S	5962R0920102KYA		

For detailed performance characteristic curves, applications information and typical applications see the latest  datasheet for their RH1086, which is available on-line at www.linear.com.

EXPORT CONTROL:

This product is controlled for export under the International Traffic in Arms Regulations (ITAR). A license from the U.S. Department of State is required prior to the export of this product from the United States.

EXPORT WARNING:

Aeroflex's military and space products are controlled for export under the International Traffic in Arms Regulations (ITAR) and may not be sold or proposed or offered for sale to certain countries. (See ITAR 126.1 for complete information.)

PLAINVIEW, NEW YORK
Toll Free: 800-THE-1553
Fax: 516-694-6715

INTERNATIONAL
Tel: 805-778-9229
Fax: 805-778-1980

NORTHEAST
Tel: 603-888-3975
Fax: 603-888-4585

SE AND MID-ATLANTIC
Tel: 321-951-4164
Fax: 321-951-4254

WEST COAST
Tel: 949-362-2260
Fax: 949-362-2266

CENTRAL
Tel: 719-594-8017
Fax: 719-594-8468



www.aeroflex.com info-ams@aeroflex.com

Aeroflex Microelectronic Solutions reserves the right to change at any time without notice the specifications, design, function, or form of its products described herein. All parameters must be validated for each customer's application by engineering. No liability is assumed as a result of use of this product. No patent licenses are implied.



Our passion for performance is defined by three attributes represented by these three icons: solution-minded, performance-driven and customer-focused

LT, LTC, , Linear Technology and the Linear logo are registered trademarks and RH1086 is copyright Linear Technology Corporation.