

# SSO-AD-230-TO52-S1

## Avalanche Photodiode

### Special characteristics:

**High gain at low bias voltage**  
**Fast rise time**  
**230 µm diameter active area**  
**low capacitance**



<b>Parameters:</b>	
active area	0,042 mm <sup>2</sup> Ø 230 µm
dark current <sup>1)</sup> (M=100)	max. 1,5 nA typ. 0,6 nA
Total capacitance <sup>1)</sup> (M=100)	typ. 1,5 pF
Break-down voltage U <sub>BR</sub> (at I <sub>D</sub> =2µA)	(90 ... 240) typ. 120 - 190 V
Temperature coefficient of U <sub>BR</sub>	typ. 0,4 %/°C
Spectral responsivity (at 780 nm)	min. 0,40 A/W typ. 0,45 A/W
Cut-off frequency (-3dB)	typ. 2 GHz
Rise time	typ. 180 ps
Optimum gain	50 - 60
Gain M	min 200
"Excess Noise" factor (M=100)	typ. 2,2
"Excess Noise" index (M=100)	typ. 0,2
Noise current (M=100)	typ. 0,5 pA/Hz <sup>½</sup>
N.E.P. (M=100, 880 nm)	typ. 1 * 10 <sup>-14</sup> W/Hz <sup>½</sup>
Operating temperature	-20 ... +70°C
Storage temperature	-60 ... +100°C
<b>1) measurement conditions:</b> Setup of photo current 10nA at M=1 and irradiation by a NIR-LED (880 nm, 80 nm bandwidth).  Rise of the photo current up to 1 µA, (M=100) by internal multiplication due to an increasing bias voltage.	

### Package (TO52 S1) :

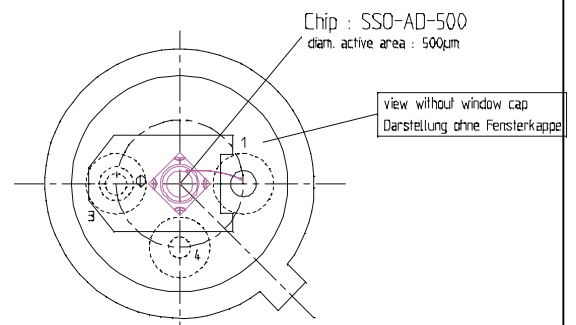
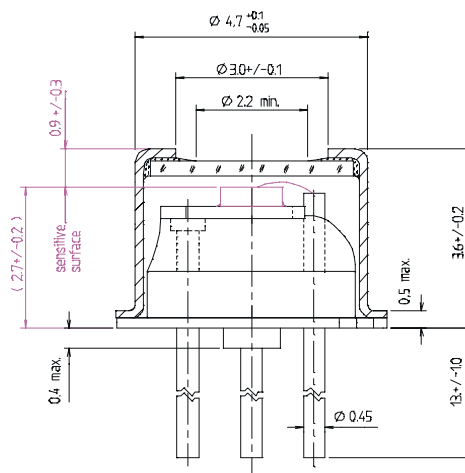
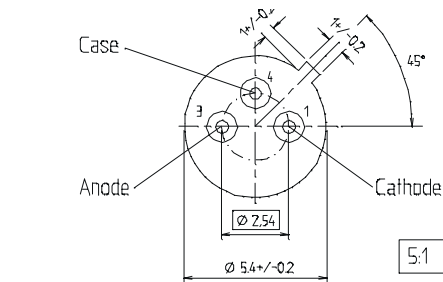

**SSO - AD - serie**  
Spectral Responsivity at M=1

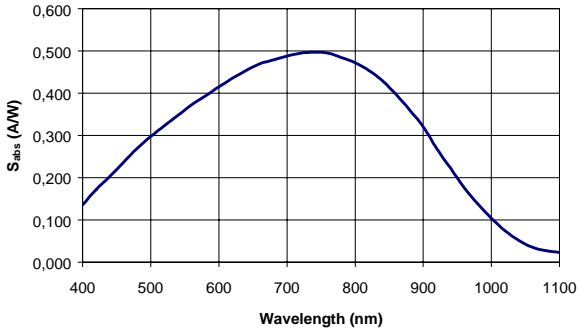

**SSO - AD - serie**  
Spectral Responsivity at M=100

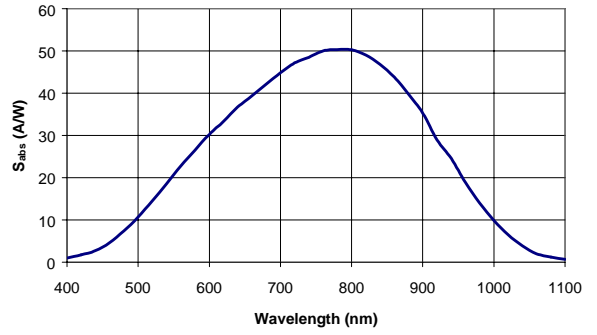

**SSO - AD - serie**  
quantum efficiency for M=1

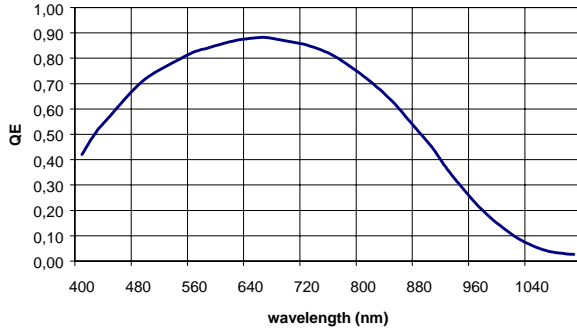

**SSO-AD 230**  
 $C_{tot}=f(U_R)$  at  $f=100\text{kHz}$

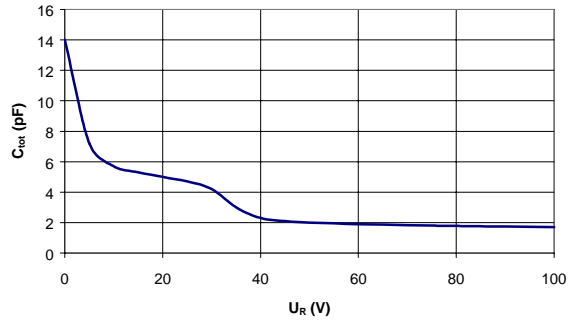

**SSO-AD 230**  
dark current =  $f(U_R)$

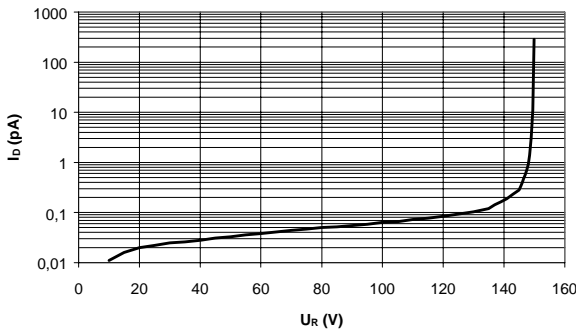

**SSO-AD 230**  
gain =  $f(U_R/U_{BR})$  at  $\lambda = 880\text{ nm}$

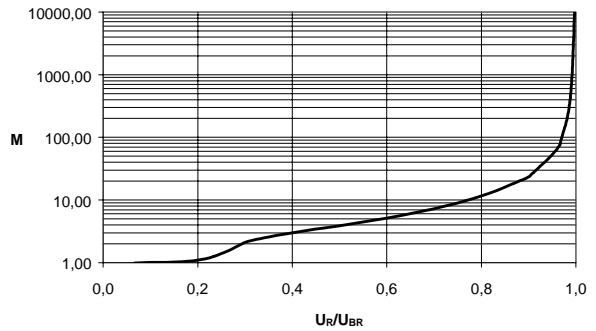

**Maximum Ratings:**

- max. electrical power dissipation 100 mW at 22°C
- max. optical peak value, once 200 mW for 1 s
- max. continuous optical operation  $I_{Ph} (DC) \leq 250 \mu A$   
 $\leq 1\text{ mA}$  for signal 50  $\mu s$  "on" / 1 ms "out"
- $( P_{electr.} = P_{opt.} * S_{abs} * M * U_R )$

**Application hints:**

- Current limit is to be realized via protecting resistor or current limiting - IC inside the supply voltage.
- Use of low noise read-out - IC.
- For higher gain a regulation of bias voltage due to the temperature is to be realized.
- For very small signals stray light (noise source) is to be excluded by filters in order to improve the signal-noise relation.
- Avoid touching the window with fingers!
- Careful cleaning with Ethyl alcohol possible.
- Avoid use of pointed and scratching tools!

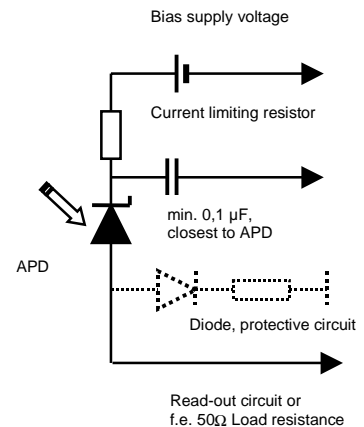

**Handling precautions:**

- Soldering temperature 260°C for max. 10 s. The device must be protected against solder flux vapour!
- min. Pin - length 2mm
- ESD - protection Only small danger for the device. Standard precautionary measures are sufficient.
- Storage Store devices in conductive foam.