



LIGITEK ELECTRONICS CO.,LTD.
Property of Ligitek Only

High Power Light LED



Lead-Free Parts

LGX12NAS-521E-T75-A02

DATA SHEET

DOC. NO : QW0905-LGX12NAS-521E-T75-A02

REV. : A

DATE : 04 - Sep. - 2013



Features

- * High Flux per LED
- * Very long operating life(up to 100k hours).
- * Available in White.
- * More Energy Efficient than Incandescent and most Halogen lamps.
- * Low voltage DC operated..
- * Cool beam, safe to the touch.
- * Instant light(less than 100 ns).
- * Fully dimmable.
- * No UV.

Typical Applications

- * Reading Light (car,bus,aircraft)
- * Portable(flashlight,bicycle).
- * LCD Backlights / Light Guides.
- * Automotive Exterior (Stop-Tail-Turn,CHMSL,Mirror Side Repeat).
- * Commercial and Residential Architectural lighting.
- * Mini-accent / Uplighters / Downlighters / Orientation lighting
- * Fiber Optic Alternative / Decorative / Entertainment lighting.
- * Security / Garden lighting.
- * Cove / Undershef / Task lighting.
- * Traffic signaling / Beacons / Rail crossing and Wayside lighting.
- * Decorative.
- * Sign and channel Letter.

Dimension

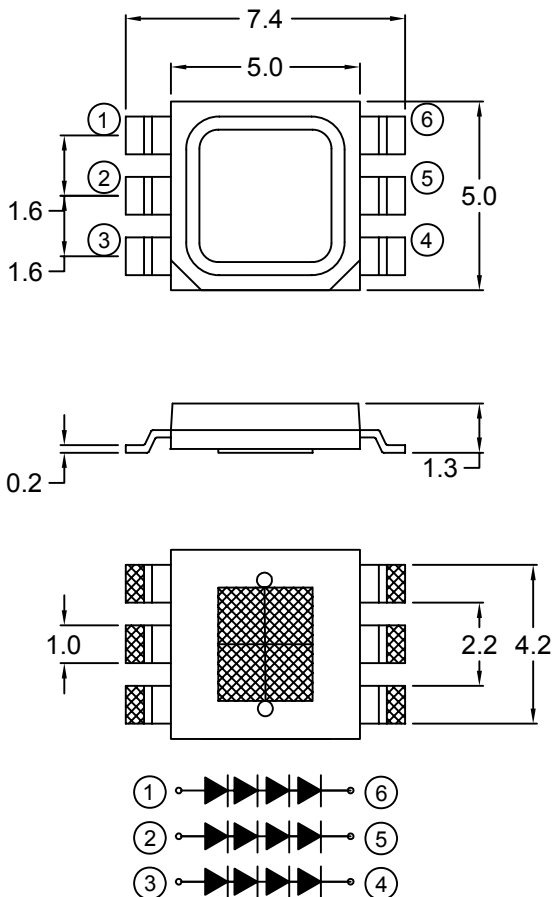

Recommended Solder Patter

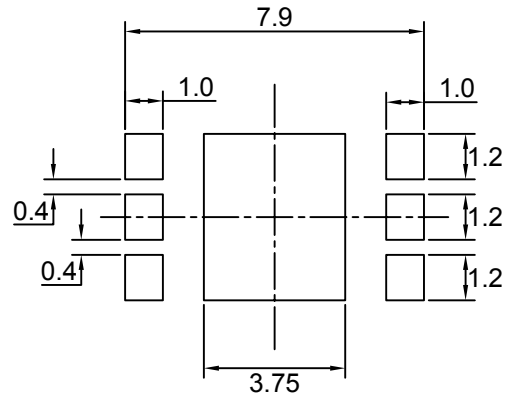

Note : The tolerances unless mentioned is ± 0.1 mm,Unit=mm.

Note : 1.All dimension are in millimeter tolerance is ± 0.2 mm unless otherwise noted.
2.Specifications are subject to change without notice.

Absolute Maximum Ratings at Ta=25°C

Parameter	Symbol	Ratings	UNIT
		White	
DC Forward Current	IF	75	mA
Power Dissipation	PD	1.1	W
Peak pulse current Duty 1/10@10KHz	IFP	150	mA
LED junction Temperature	Tj	125	°C
Reverse Current(VR=5V)	Ir	50	µA
Electrostatic Discharge	ESD	500	V
Storage Temperature	Tstg	-30 ~ +100	°C
Operating Temperature	Topr	-20 ~ +80	°C
Soldering Temperature	Tp	260	°C
Hand Soldering Time at320°C(Max)	Tsol	3	seconds

Note:

- 1.Proper current derating must be observed to maintain temperature below the maximum.
- 2.LEDS are not designed to be driven in reverse bias.

Luminous Intensity Characteristics at 75mA (Ratings At 25°C Ambient)

PART NO	Emission Color	Luminous Flux @75mA			Units
		Min.	Typ.	Max.	
LGX12NAS-521E-T75-A02	White	100	115	---	lm

Note :

1. White emitters are built with InGaN.
2. Luminous Intensity is measured with an accuracy of ±10%

Forward Voltage Characteristics at 75mA

(Ratings At 25°C Ambient)

PART NO	Emission Color	Vf			Units
		Min.	Typ.	Max.	
LGX12NAS-521E-T75-A02	White	11	----	15	V

Note : Forward Voltage is measured with an accuracy of $\pm 0.1V$

Chromaticity Coordinates Characteristics at 75mA

(Ratings At 25°C Ambient)

PART NO	Emission Color	Chromaticity Coordinates			
		X		Y	
		Min.	Max.	Min.	Max.
LGX12NAS-521E-T75-A02	White	0.3441	0.3736	0.3428	0.3874

Note : ± 0.01 is tester tolerance.

Emission Angle Characteristics at 75mA

(Ratings At 25°C Ambient)

PART NO	Emission Color	Lambertian	Units
LGX12NAS-521E-T75-A02	White	120	Degess

Bin Code Description

Bin Code		
Luminous Intensity	CIE	Forward Voltage
F100V	45K-1	11-15

Luminous Intensity (mcd) @IF=75mA		
Bin Code	Min.	Max.
F100V	100	105
F105V	105	110
F110V	110	115
F115V	115	120
F120V	120	125

Color Rank @IF=75mA
45K-1
45K-2
45K-3
45K-4
50K-1
50K-2

Bins Code of chromaticity coordinates

Color Coordiante at75mA									
CCT(K)	BIN CODE	1		2		3		4	
		X	Y	X	Y	X	Y	X	Y
4500	45K-1	0.3736	0.3874	0.3642	0.3805	0.3617	0.3663	0.3703	0.3726
	45K-2	0.3703	0.3726	0.3617	0.3663	0.3591	0.3522	0.3670	0.3578
	45K-3	0.3642	0.3805	0.3548	0.3736	0.3530	0.3601	0.3617	0.3663
	45K-4	0.3617	0.3663	0.3530	0.3601	0.3512	0.3465	0.3591	0.3522
5000	50K-1	0.3551	0.3760	0.3464	0.3688	0.3452	0.3558	0.3533	0.3624
	50K-2	0.3533	0.3624	0.3452	0.3558	0.3441	0.3428	0.3515	0.3487

NOTE: Tolerance on each color bin(x,y)is±0.01

CIE Chromaticity Diagram

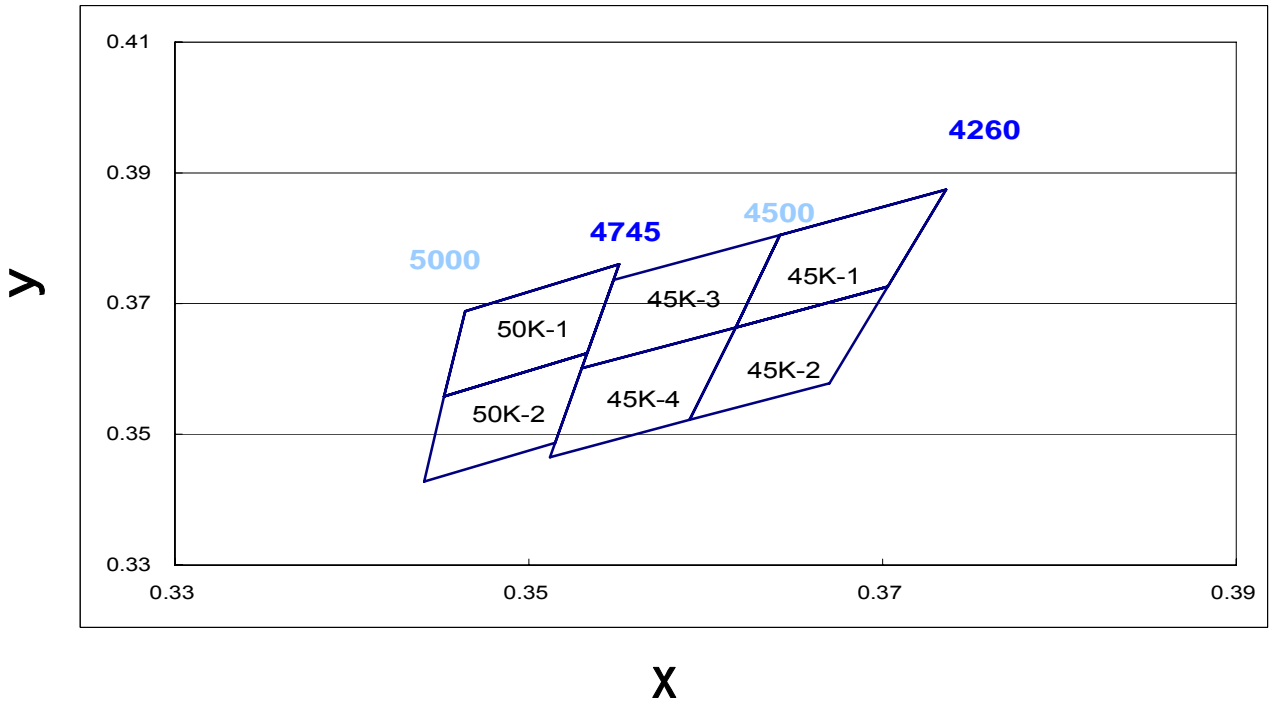

Recommended Profile for Reflow Soldering

Pb -free solder temperature profile

Pb -free solder Temperature profile	
Pre-heat	180-200°C
Pre-heat time	120 Sec Max
Peak-Temperature	260°C Max
Soldering time condition	10 Sec Max

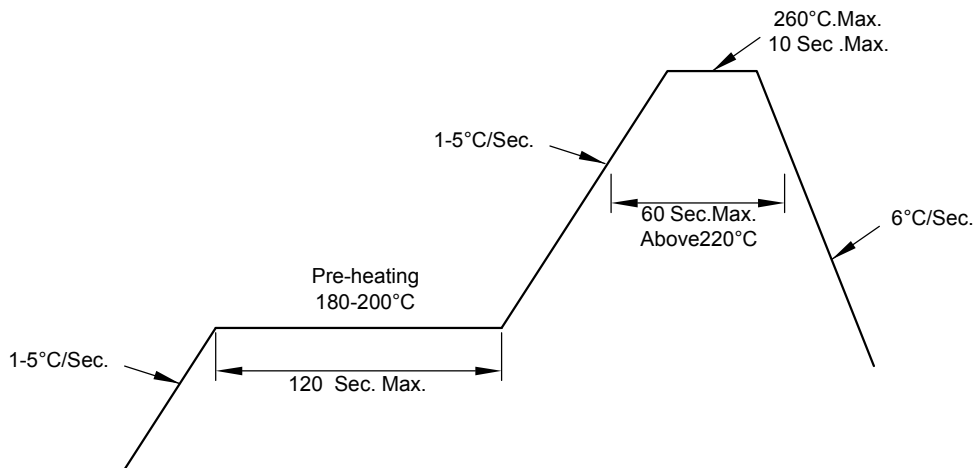

- (1) Reflow soldering should not be done more than two times.
- (2) When soldering, do not put stress on the LEDs during heating.
- (3) After soldering, do not warp the circuit board.
- (4) The encapsulated material of the LEDs is silicone.
Precautions should be taken to avoid the strong pressure on the encapsulated part. So when using the chip mounter, the picking up nozzle that does not affect the silicone resin should be used.

Hand Soldering Conditions:

Do not exceed 3 seconds at maximum 320°C under soldering iron. (one time only)

Typical Electro-Optical Characteristics Curve

Fig.1 Forward current vs. Forward Voltage

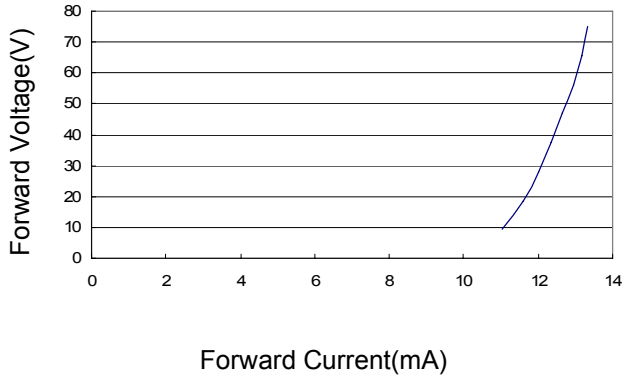

Fig.2 Forward current vs. Luminous Intensity

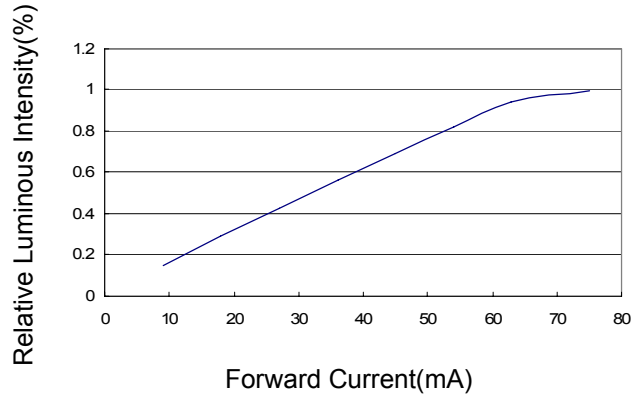

Fig.3 Directivity Radiation

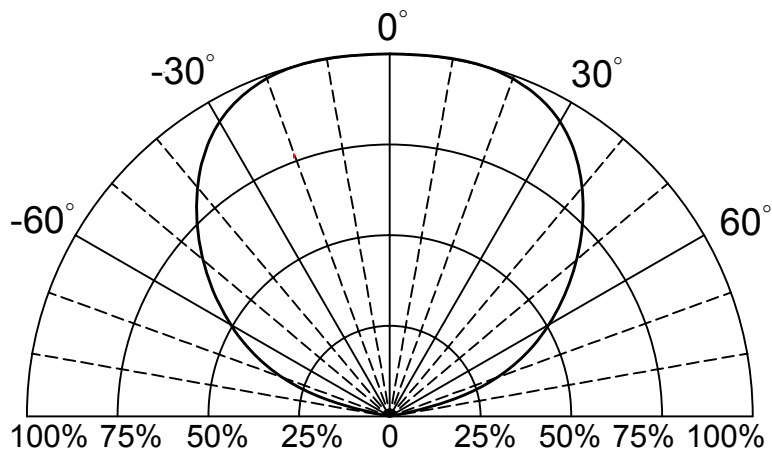
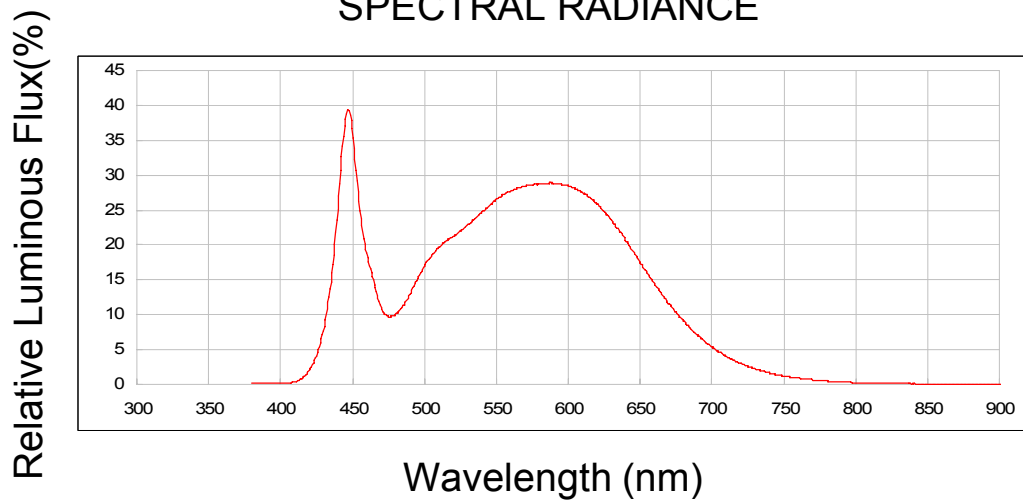
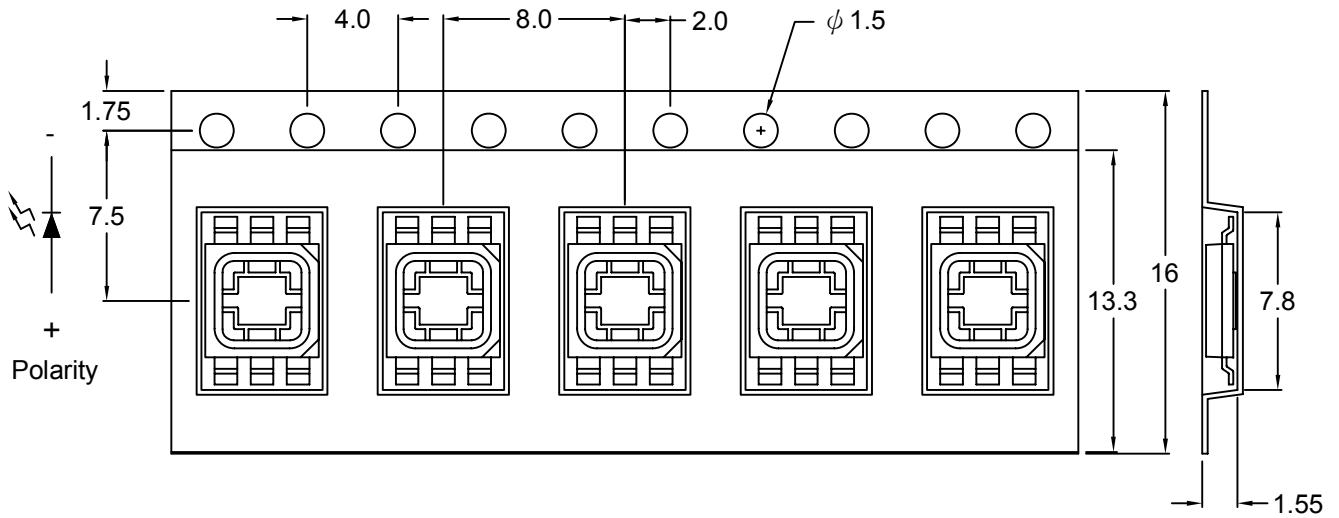

Fig.5 Luminous Spectrum (Ta=25 °C)
SPECTRAL RADIANCE



Carrier Type Dimensions







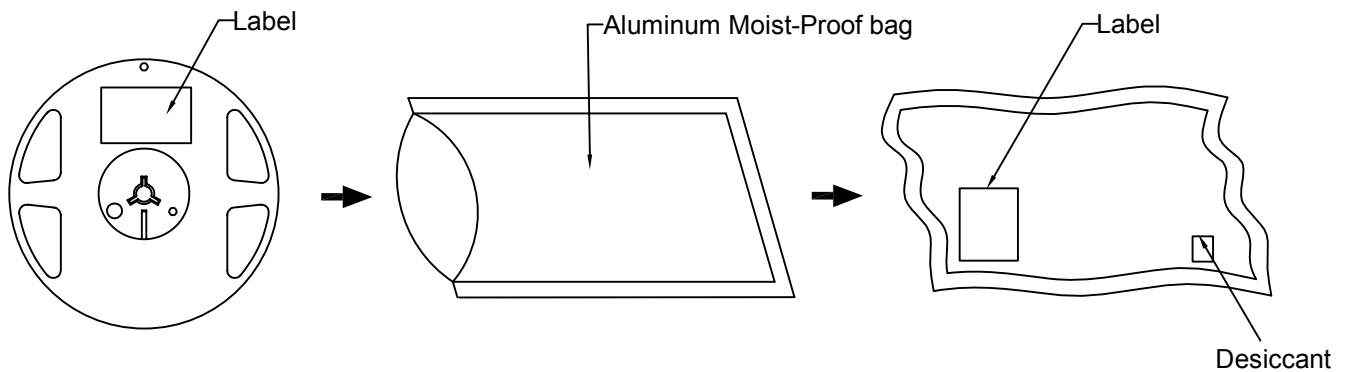

Note : The tolerances unless mentioned is $\pm 0.2\text{mm}$.

Packing Specifications



Label Explanation

	LIGITEK ELECTRONICS CO., LTD.	
		
	PART :	LGX12NAS-521E-T75-A02
		
	LOT :	GS11390168
		
QTY(PCS):	1500	
		
BIN/HUE :	F100V/45K-1	VF:11-15

BIN : Luminous Intensity

HUE : Chromaticity Coordinates
(CIE_x , CIE_y)

VF : Forward Voltage

Reel Dimensions

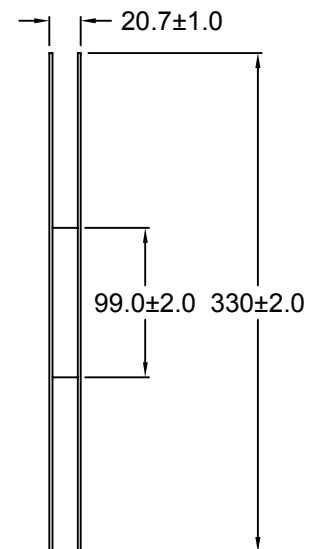
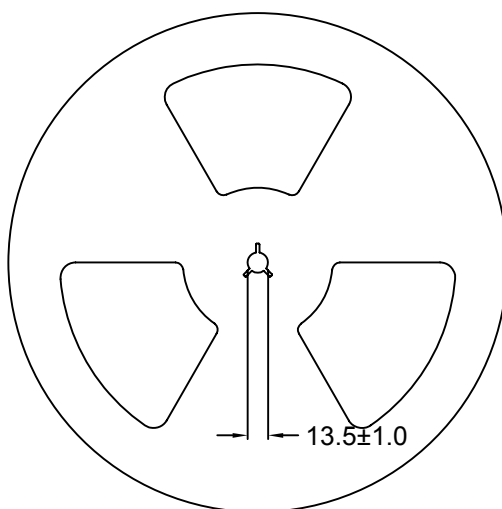

Reliability Test

(1) Test items and results

Classification	Test Item	Test Condition	Sample Size
Endurance Test	Operating Life Test	1.Ta=Under Room Temperature As Per Data Sheet Maximum Rating. 2.If=75mA 3.t=1000 hrs	22
	High Temperature Storage Test	1.Ta=100°C 2.t=1000 hrs	22
	Low Temperature Storage Test	1.Ta=-40°C 2.t=1000 hrs	22
	High Temperature High Humidity Storage Test	1.Ta=85°C 2.RH=85% 3.t=1000 hrs	22
Environmental Test	Thermal Shock Test	1.Ta=-40°C(30min) -100°C(30min) 2.total 100 cycles	22
	Reflow Soldering Test	1.T.Sol=260°C±5°C 2.Dwell Time= 10 Sec.Max.	22
	Temperature Cycling	1.100°C ~ 25°C ~ -40°C 30mins 5mins 30mins 2.100 Cyeles	22

(2) Criteria for judging the damage

Item	Symbol	Test Conditions	Criteria for Judgement	
			Min.	Max.
Forward Voltage	Vf	If=75mA	-	U.S.L x1.2
Reverse Current	Ir	Vr=5V	-	U.S.L x2.0
Luminous Intensity	Iv	If=75mA	L.S.L x 0.7	-

Note:

1.U.S.L.:Upper Standard Level.

2.L.S.L.:Lower Standard Level.