

COIL FORMERS

General data CP-P18/11

PARAMETER	SPECIFICATION
Coil former material	polybutyleneterephtalate (PBT), glass reinforced, flame retardant in accordance with "UL 94V-0"; UL file number E45329 (R)
Maximum operating temperature	155 C, "IEC 60085", class F

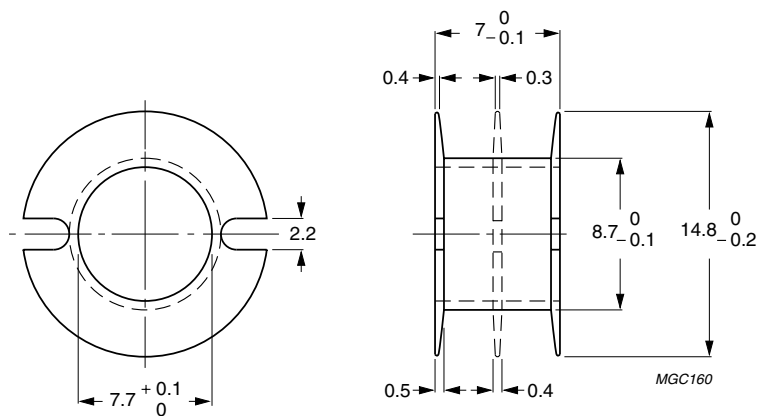

Dimensions in mm.

Fig.3 CP-P18/11 coil former.

Winding data for CP-P18/11 coil former

NUMBER OF SECTIONS	WINDING AREA (mm ²)	MINIMUM WINDING WIDTH (mm)	AVERAGE LENGTH OF TURN (mm)	TYPE NUMBER
1	17.1	5.7	36.6	CP-P18/11-1S
2	2 7.95	2 2.65	36.6	CP-P18/11-2S
3	3 4.95	3 1.6	36.6	CP-P18/11-3S