

PLEASE CHECK WWW.MOLEX.COM FOR LATEST PART INFORMATION

Part Number: **0192030005**
Status: **Active**
Description: Krimptite™ Temp-Term Ring Tongue Terminal for 18 to 22 AWG Wire, Stud Size 1/4, Mylar Tape Carrier

Documents:

[Drawing \(PDF\)](#) [RoHS Certificate of Compliance \(PDF\)](#)

Agency Certification

UL E32244

General

Product Family Ring and Spade Terminals
 Series 19203
 Crimp Quality Equipment Yes
 Mil-Spec N/A
 Product Name Krimptite™, Temp-Terms
 Type Ring

Physical

Barrel Type Closed
 Insulation None
 Material - Plating Mating Tin
 Packaging Type Adhesive Tape on Reel
 Stud Size 1/4" (M6)
 Wire Size AWG 18, 20, 22
 Wire Size mm² 0.25 - 1.50

Material Info

Old Part Number A-S-122-14T

Reference - Drawing Numbers

Sales Drawing SD-19203-036



*Series
image - Reference only*

EU RoHS

**ELV and RoHS
Compliant**

REACH SVHC

Contains SVHC: No

Halogen-Free

Status

Not Reviewed

China RoHS



**Need more information on product
environmental compliance?**

Email productcompliance@molex.com
 For a multiple part number RoHS Certificate of
 Compliance, [click here](#)

Please visit the [Contact Us](#) section for any
 non-product compliance questions.

Search Parts in this Series

19203Series

Application Tooling | [FAQ](#)

*Tooling specifications and manuals are
 found by selecting the products below.
 Crimp Height Specifications are then
 contained in the Application Tooling
 Specification document.*

Global

Description	Product #
ATP Perishable Tool Kit used in ATP presses that process product on tape	<u>0190270026</u>
Mini-Mac™ Applicator	<u>0638854500</u>

LOOSE PIECE		TAPE MOUNTED		STUD SIZE	DIMENSIONS			
MATERIAL NO.	ENG. NO.	MATERIAL NO.	ENG. NO.		"S" ±.007/0.18	"W" MAX	"C" MIN	"L" MAX
192030486	A-S-122-14	192030005	A-S-122-14T	1/4"	.256/6.50	.467/11.86	.427/10.85	.894/22.71
192030483	A-S-132-06	192030011	A-S-132-06T	06	.146/3.71	.270/6.86	.238/6.05	.611/15.52
192030485	A-S-132-08	192030014	A-S-132-08T	08	.169/4.29	.270/6.86	.238/6.05	.611/15.52
192030387	A-S-133-10	192030016	A-S-133-10T	10	.209/5.31	.325/8.26	.270/6.86	.666/16.92

Ⓒ

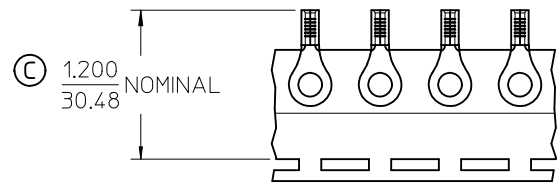
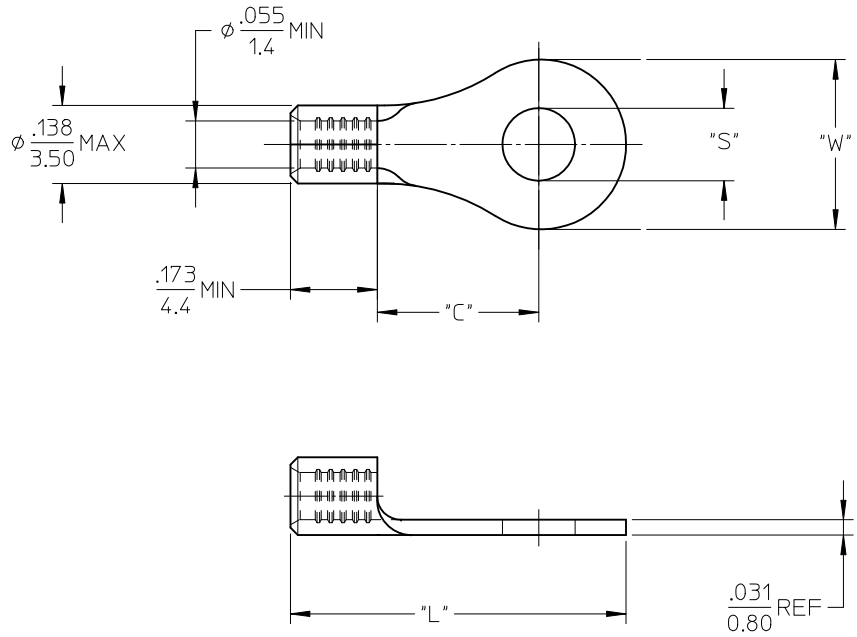

PARTS ON TAPE

NOTE(S):

1. MATERIAL: STEEL
2. WIRE SIZE: 22-18 AWG (0.25-1.5 MM²)
3. FINISH: NICKEL PLATING
4. PARTS ARE ROHS COMPLIANT.
5. AMBIENT OPERATING TEMPERATURE UP TO 900 °F (483 °C).

TAPET HT, CONSOL P/N'S EC NO: WNA2010-0619 DRW: WETHRODAHL 2010/04/23 CHKD: JMACNEIL 2010/04/23 APPR: JMACNEIL 2010/06/01	QUALITY SYMBOLS ▽=0 ▽=0	GENERAL TOLERANCES (UNLESS SPECIFIED)		DIMENSION STYLE IN/MM		SCALE 4:1	DESIGN UNITS INCH	THIRD ANGLE PROJECTION		
		4 PLACES ± --- ± ---	3 PLACES ± --- ± ---	2 PLACES ± --- ± ---	1 PLACE ± --- ± ---	DRAWN BY EHILE	DATE 2006/09/22	TITLE RING TONGUE TERMINAL, 22-18 AWG, KRIMPTITE, 900 DEG F (483 DEG C)		
		ANGULAR ± --- °				CHECKED BY JMACNEIL	DATE 2006/09/22			
		DRAFT WHERE APPLICABLE MUST REMAIN WITHIN DIMENSIONS				APPROVED BY JMACNEIL		DATE 2006/09/22	MOLEX INCORPORATED DOCUMENT NO. SD-19203-036	
				MATERIAL NO.		SEE CHART		SHEET NO. 1 OF 1		