

Final Control Elements

SERVO-TOP II ELECTRONIC ACTUATOR

linear type; rated thrust 3000N

Functions & Features

- High-resolution electronic actuator for control valves
- Fast action control without overshoot
- Equipped with high-performance stepping motor
- Usable in both low and high temperature ranges
- Excellent in hysteresis, linear, and resolution characteristics
- Disc spring with buffer incorporated

Typical Applications

- Fuel cell systems
- Capacity control of compressor for refrigerating machines
- High-speed & high-performance control valves used in various plants and industries

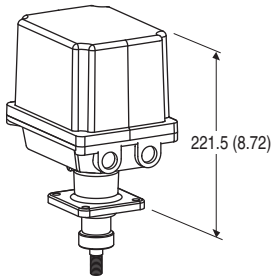

MODEL: PSN1G-A21-A

ORDERING INFORMATION

- Code number: PSN1G-A21-AR
- Use Ordering Information Sheet (No. ESU-4876).
Ex-factory settings will be as shown in the table below if not specified by the user.

EX-FACTORY SETTINGS

Item	Setting
Action	Reverse
Operations at abnormally low input	Stop
Output stem ex-factory position	Upper-end
Opening/Closing speed	7.5 sec./ 20 mm
Deadband setting	0.1 %
Restart limiting timer	0.1 sec.

OUTPUT STEM OPERATION DISTANCE

A: 0-20 mm (0" to .79")

SEALING SPRING PRESSURE

2: 3000 N use

OUTPUT STEM TYPE

1: M14 male screw, pitch 1.5

INPUT

Current

A: 4 - 20 mA DC (Input resistance 250 Ω)

POWER SUPPLY VOLTAGE

DC Power

R: 24 V DC

(Operational voltage range 24 V ±10 %, ripple 10 %p-p max.)

Common Specifications

- Output signal: 4 - 20 mA DC
(allowable load resistance: ≤ 300 Ω)
- Rated thrust: 3000 N
- Maximum thrust: 3200 N (reference value)
- Thrust when output stem is locked: 3500 N min.
(reference value)
- Operation speed: 7.5 sec./20 mm

RELATED PRODUCTS (Products sold separately)

- Manual operation handle (model: HPSN)
- Programming Unit (model: PU-2x)

GENERAL SPECIFICATIONS

Degree of protection: IP66

Action: "Reverse" action, in which the output stem retracts or moves upward as the input signal increases.

Operation at abnormally low input:

(selectable with DIP switches)

- Extend/move downward
- Retract/move upward
- Stop

Abnormal signal level: ≤ 1.48(±0.4) mA DC

Wiring conduits: G 1/2 female thread (two)

Terminal block: 7.62 mm pitch; M3 screw terminals (torque 0.5 N·m)

Screw terminal: Nickel-plated brass

Housing material: Diecast aluminum

Coating: Silver color

Drive: Stepping motor

Insulation class: E

Power control element: Power MOS-FET
Deadband adjustment: 0.1 – 5.0 %
Restart limiting timer adjustment: 0 – 30 sec.
Isolation: Signal or power to metallic housing
Fuse: 6 A (replaceable)
Protective functions: Error detection, Abnormal temperature increase protection, Motor preheating function
Power indicator: Green LED is on while the power is supplied.
Input indicator: Green LED is ON while normal signal is input
Alarm indicator:
Red LED turns on when an error is detected; and
Red LED blinks at 1-sec. intervals when abnormal temperature rise is detected.
Manual operation: Available
User-configurable items:
Programming Unit (model: PU-2x) allows programming of:
Full-open(upper-end)/full-closed(lower-end) positions;
Extended/retracted side limiters;
Deadband; and
Restart limiting timer

OUTPUT SIGNAL SPECIFICATIONS

■ **Position Signal:** 4 – 20 mA DC
Load resistance: $\leq 300 \Omega$

STROKE RATE

Duty cycle = Within 50 %
The unit must operate at an average duty cycle of 50% (ratio of operating time to standby time) or less.
Operation rate: Less than 13 strokes / min. (excepting momentary peak stroke rate)

INSTALLATION

Current consumption values
Standby current value: 0.15 A (25°C^{at})
Current at no load: 2.1 A (25°C^{at})
Locked rotor current: 3.7 A max.
Current in standby or non-operating state at - 25°C:
1 A (- 25°C^{at}) (approx. 2.4 A. during operation at - 25°C)
Operating temperature: -25 to +66°C (-13 to +150.8°F)
Storage temperature: -29 to +70°C (-20.2 to 158°F)
Operating humidity: 30 to 85 %RH (non-condensing)
Vibration resistance:

- Sweep endurance test
- Acceleration: 1 G (9.8 m/s²)
- Frequency: 10 to 1000 Hz
- Cycle: 20 cycles
- Sweep rate: 1 oct./min.
- Testing time: approx. 4 hr. 30 min.
- Direction: X, Y, Z

Mounting orientation:
Vertical to horizontal
(DO NOT mount upside-down or with the output stem facing upward)
Weight: Approx. 5.7 kg (12.57 lb)

PERFORMANCE

Resolution: 0.02 mm
Hysteresis: 0.15% (0.03 mm)
Linear characteristic: 0.3% (0.06 mm)
Insulation resistance: $\geq 100 \text{ M}\Omega$ with 500 V DC (signal or power to metallic housing)
Dielectric strength: 500 V AC @ 1 minute (signal or power to metallic housing)

STANDARDS & APPROVALS

EU conformity

- EMC Directive
EMI EN 61000-6-4
EMS EN 61000-6-2
- RoHS Directive
EN 50581

TERMINOLOGY

• Error Detection
When the output stem does not operate due to overload or certain malfunction despite there is a deviation between the input signal and the position signal, PSN tries to start the motor by applying a locked rotor torque up to five times. Then, if the stem still does not operate, the unit outputs an alarm signal, turns Alarm LED on, and stops the power supply to the motor.
In order to reset the unit after error detection, apply 0 % and 100 % input signals alternately for several times, or turn off and on the power voltage.

• Abnormal Temperature Increase Protection
When the internal temperature sensor detects an abnormal temperature increase in the motor, PSN blinks the alarm LED and stops power supply to the motor until the temperature decreases to an acceptable level. Usually, power supply to the motor is automatically resumed in a few minutes, however, it will take longer if the ambient temperature is higher.

• Motor Preheating Function
When the internal temperature sensor detects a temperature lower than 0°C / 32°F (approximate) on the surface of the motor, the unit supplies current to the motor to warm up the motor to 0°C / 32°F.
Keep the power voltage supplied when this unit is used in

the ambient temperature below 0°C or 32°F.

- **Hysteresis**

The output stem reciprocates i.e. moves up and down according to the input signal.

Hysteresis is the difference between the two curves of ascending and descending directions, which is expressed in percentage. In the case of PSN, the hysteresis distance is "0.03mm/MAX. = 0.15%".

- **Linear Characteristics**

The output stem reciprocates i.e. moves up and down according to the input signal.

In theory, the output stem moves by a distance proportional to the input signal.

In the case of PSN, the difference between the theoretical value and the actual distance that the output stem actually moved is "0.06mm/MAX. = 0.3%".

- **Resolution** (varies according to the deadband settings)

The output stem operates according to the input signal.

When 4 to 20 mA DC input signal is applied, the output stem follows the input signal in units of 0.16 mA.

That is, resolution of 0.1% is achieved when the output stem reciprocates i.e. moves up and down 1,000 times in units of 0.16 mA or less.

- **Operation at abnormally low input**

The output stem operates as specified when an abnormally low input is detected even though power supply voltage is being applied.

The abnormal input signal level is 1.48 (± 0.4) mA DC or lower.

The output stem operation mode can be selected from:

- Stop at the current position;
- Extend/move downward to the full-closed/lower-end position; and
- Retract/move upward to the full-open/upper-end position.

- **Restart Limiting Timer**

The output stem operates frequently (i.e. hunting occurs) when input signal is unstable and its value changes frequently, resulting in shortening the life of the product.

In order to prevent such frequent operation or hunting of the actuator, the restart limiting timer can be set (0 to 30 sec.) so as to prevent the motor from restarting for the specified period of time after reaching and stopping at the target position based on the input signal.

The unit must operate at an average duty cycle of 50% (ratio of operating time to standby time) or less. The operation rate exceeding 13 strokes / min. is regarded as hunting.

OPERATION

■ OUTPUT STEM POSITION WHEN INPUT SIGNAL IS APPLIED (Reverse action)

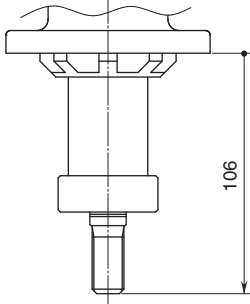
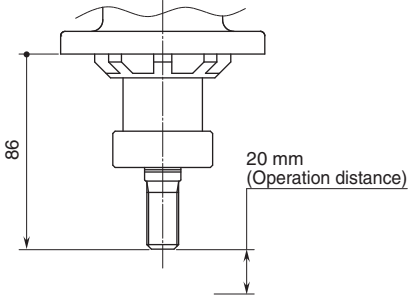
Input	4mA DC / Full-closed [Lower-end]	20mA DC / Full-open [Upper-end] position
Output Stem position		

■ OUTPUT STEM POSITION WHEN INPUT SIGNAL IS APPLIED (Direct action)

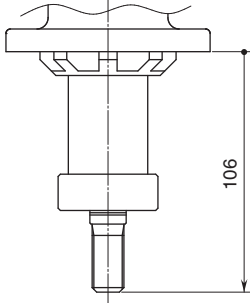
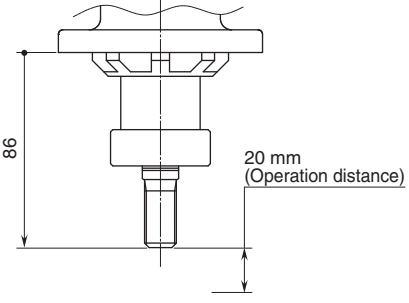
Input	20mA DC / Full-closed [Lower-end]	4mA DC / Full-open [Upper-end] position
Output Stem position		

EXTERNAL DIMENSIONS unit: mm (inch)

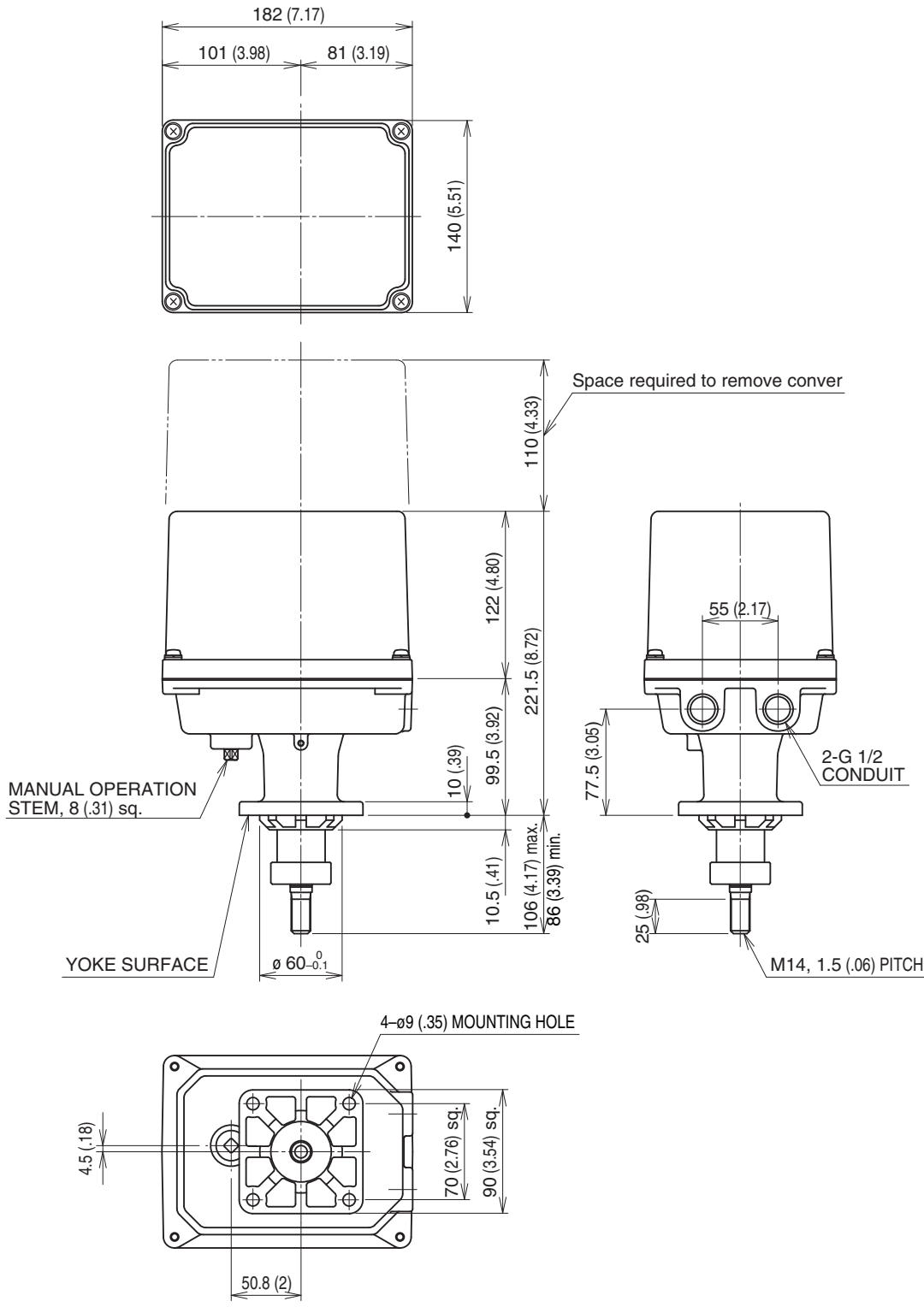

SCHEMATIC CIRCUITRY & CONNECTION DIAGRAM

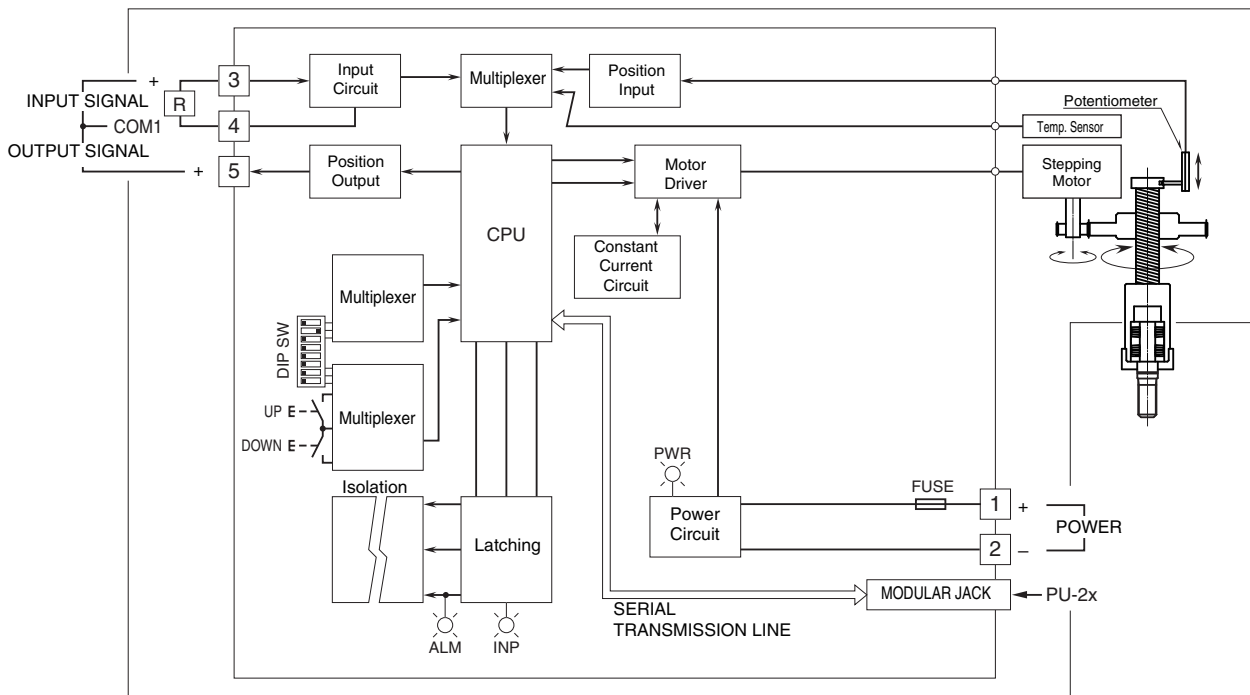

Specifications are subject to change without notice.