

# APPROVAL SHEET

**WM07B\_Q, WM04B\_Q, WM07C\_Q,  
WM04C\_Q**

**$\pm 1\%$ ,  $\pm 0.5\%$ ,  $\pm 0.25\%$ ,  $\pm 0.1\%$**

**TC50 , TC25**

High Precision Thin Film MELF Resistors

Size: 0207, 0204

AEC-Q200 Compliant



\*Contents in this sheet are subject to change without prior notice.

## FEATURE

1. SMD enabled structure thin film resistor
2. High reliability and stability of  $\pm 0.3\%$  and below per customer request
3. High precision of TCR: 50 & 25 ppm/ $^{\circ}\text{C}$  and below per customer request
4. Best in class pulse load capability
5. RoHS compliant and lead free
6. AEC-Q200 Compliant

## APPLICATION

- Medical equipment
- Measuring instrument
- Communication device
- Power / Meter Converter

## DESCRIPTION

A uniform alloy film is deposited on a high grade ceramic body ( $\text{Al}_2\text{O}_3$ ) and achieved the desired temperature coefficient by annealing. Nickel plated termination caps are firmly attached on the ceramic body. It is achieved the target value by smoothly cutting a helical groove in the resistive layer without damaging the ceramic body. The resistive film is covered by epoxy molding compound designed for electrical, mechanical and climatic protection. For environmental soldering issue, Nickel plated terminations receive a final pure tin on it. Four color code rings designate the resistance value in accordance with IEC 60062.

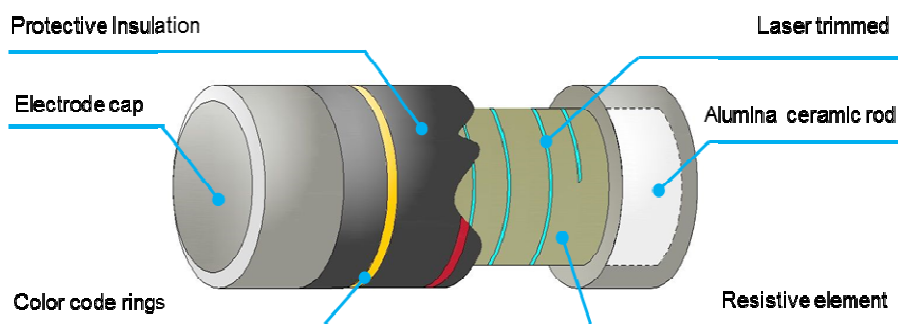

Fig 1. Construction of MELF

### QUICK REFERENCE DATA

Item	General Specification			
Series No.	WM07B_Q	WM07C_Q	WM04B_Q	WM04C_Q
Size code	0207 ( 6123 )		0204 ( 3715 )	
Resistance Tolerance	±1%, ±0.5%, ±0.25%, ±0.1%			
Resistance Range	0.2Ω ~1M	10Ω~1MΩ	0.2Ω ~1M	10Ω~1MΩ
TCR (ppm/°C)	±50ppm/C	±25ppm/C	±50ppm/C	±25ppm/C
Max. dissipation at T <sub>amb</sub> =70°C	1/2W		1/4W	
Max. Operating Voltage (DC or RMS)	300V		200V	
Max. Overload Voltage (DC or RMS)	600V		400V	
Operating temperature	- 55 ~ +155 °C			

Note :

1. This is the maximum voltage that may be continuously supplied to the resistor element, see "IEC publication 60115-8"
2. Max. Operation Voltage : So called RCWV (Rated Continuous Working Voltage) is determined by

$$RCWV = \sqrt{\text{Rated Power} \times \text{Resistance Value}} \text{ or Max. RCWV listed above, whichever is lower.}$$

### DIMENSIONS:( unit:mm)

Type	0207	0204
L	5.90±0.20	3.50±0.10
D	2.20±0.10	1.40±0.15
K	1.40±0.10	0.90±0.10
Weight (g) 1000pcs	87.81	22.34

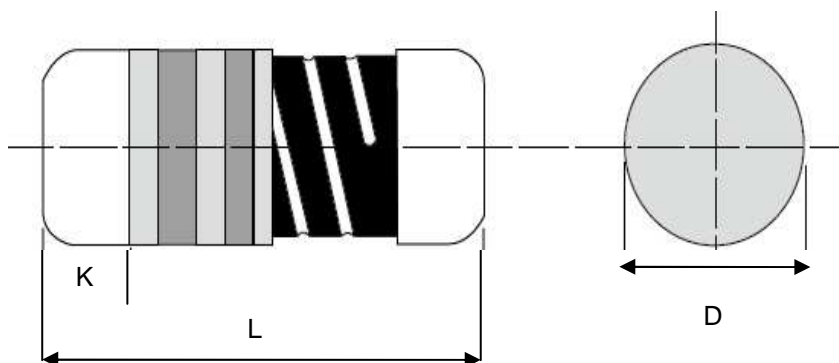

## MARKING & RESISTANCE RANGE / TOLERANCE

Standard Resistance Values															
±1%、±0.5%、±0.25%、±0.1%															
E192															
100	115	133	154	182	210	243	280	324	374	432	499	576	665	768	887
101	117	135	156	184	213	246	284	328	379	437	505	583	673	777	898
102	118	137	158	187	215	249	287	332	383	442	511	590	681	787	909
104	120	138	160	189	218	252	291	336	388	448	517	597	690	796	920
105	121	140	162	191	221	255	294	340	392	453	523	604	698	806	931
106	123	142	164	193	223	258	298	344	397	459	530	612	706	816	942
107	124	143	165	196	226	261	301	348	402	464	536	619	715	825	953
109	126	145	167	198	229	264	305	352	407	470	542	626	723	835	965
110	127	147	169	200	232	267	309	357	412	475	549	634	732	845	976
111	129	149	174	203	234	271	312	361	417	481	556	642	741	856	988
113	130	150	178	205	237	274	316	365	422	487	562	649	750	866	
114	132	152	180	208	240	277	320	370	427	493	569	657	759	876	

Color 1 Coding	Color 2 Coding	Color 3 Coding	Color 4 Coding
	0	0	10 <sup>0</sup>
1	1	1	10 <sup>1</sup>
2	2	2	10 <sup>2</sup>
3	3	3	10 <sup>3</sup>
4	4	4	10 <sup>4</sup>
5	5	5	10 <sup>5</sup>
6	6	6	
7	7	7	
8	8	8	10 <sup>-1</sup>
9	9	9	10 <sup>-2</sup>

Resistance values more than two digiting tags (<1R) or more than three digiting tags (>1R) will not provide marking.

## FUNCTIONAL DESCRIPTION

### Product characterization

Standard values of nominal resistance are taken from the E192 series for resistors with a tolerance of  $\pm 1\%$ ,  $\pm 0.5\%$ ,  $\pm 0.25\%$ ,  $\pm 0.1\%$ . The values of the E192 series are in accordance with "IEC publication 60063".

### DERATING

The power that the resistor can dissipate depends on the operating temperature; see Fig.2

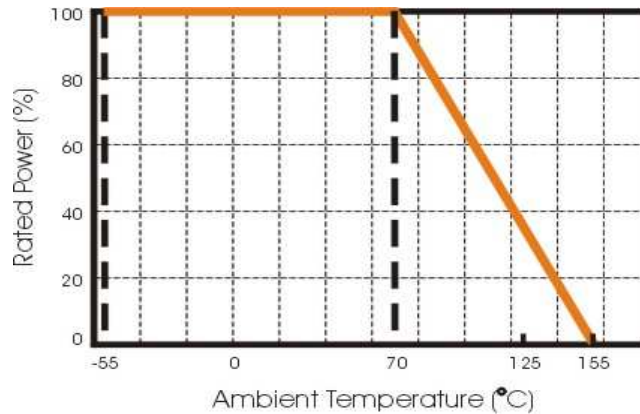

Fig.2 Maximum dissipation in percentage of rated power  
As a function of the ambient temperature

### MOUNTING

Due to their rectangular shapes and small tolerances, Surface Mountable Resistors are suitable for handling by automatic placement systems.

Cylindrical placement can be on ceramic rods and printed-circuit boards (PCBs).

Electrical connection to the circuit is by individual soldering condition.

The end terminations guarantee a reliable contact.

### RECOMMEND LAND PATTERN

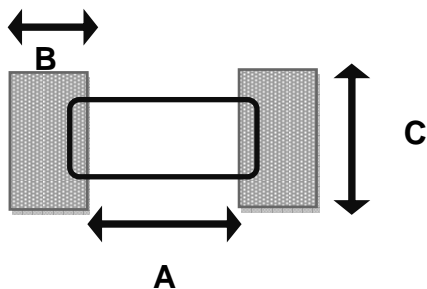

Type	0207	0204
A (mm)	3.0	1.6
B (mm)	1.7	1.2
C (mm)	2.4	1.6

## SOLDERING CONDITION

The robust construction of cylindrical resistors allows them to be completely immersed in a solder bath of 260°C for 10 seconds. Therefore, it is possible to mount Surface Mount Resistors on one side of a PCB and other discrete components on the reverse (mixed PCBs).

Surface Mount Resistors are tested for solderability at 235°C during 2 seconds within lead-free solder bath. The test condition for no leaching is 260°C for 30 seconds. Typical examples of soldering profile and condition that provide reliable joints without any damage are given in Fig 3. and Table 1.

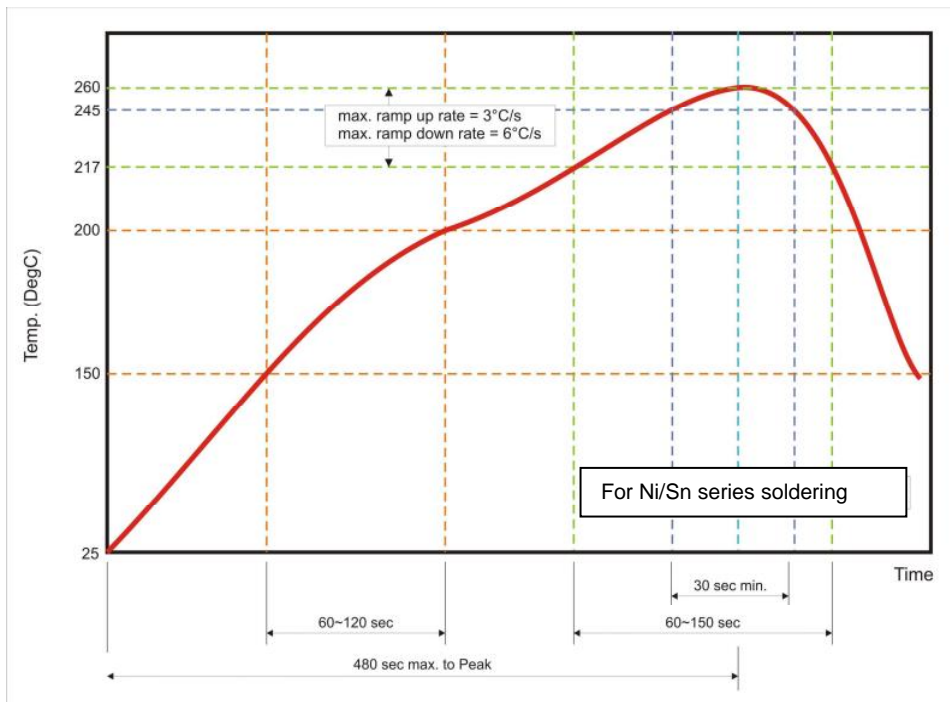

Fig. 3 Infrared soldering profile for MELF Resistors

Table 1. Infrared soldering condition for MELF Resistors

Temperature Condition	Exposure Time
Average ramp-up rate (217°C to 260°C)	Less than 3°C/second
Between 150 and 200°C	Between 60-120 seconds
> 217°C	Between 60-150 seconds
Peak Temperature	260°C +0/-5°C
Time within 245°C	Min. 30 seconds
Ramp-down rate (Peak to 217°C)	Less than 6°C/second
Time from 25°C to Peak	No greater than 480 seconds

## CATALOGUE NUMBERS

The resistors have a catalogue number starting with .

WM07	C	xxxx	B	T	L	Q
<b>Size code</b>	<b>TCR code</b>	<b>Resistance code</b>	<b>Tolerance</b>	<b>Packaging code</b>	<b>Termination code</b>	<b>Special code</b>
WM07 : 0207	B : 50 ppm	102Ω =1020	F: ±1.0%	T : Taped & Reeled	L: Sn base (lead free)	Q : epoxy molding compound type
WM04 : 0204	C : 25 ppm	37.4KΩ =3742	D: ±0.5%			
		220Ω =2200	C: ±0.25%			
		20Ω =20R0	B: ±0.1%			
		0.1Ω =R100				
		0.033Ω =R033				

1. Reeled tape packaging: 12mm width plastic taping for WM07.

2. Reeled tape packaging: 8mm width plastic taping for WM04.

2,000pcs/reel for WM07.

3,000pcs/reel for WM04.



**TEST AND REQUIREMENTS (JIS C 5201-1 : 1998)**

TEST	PROCEDURE	REQUIREMENT	
		10Ω to 250KΩ	<10Ω & >250KΩ
Electrical Characteristics <b>IEC 60115-1 4.8</b>	- DC resistance values measurement - Temperature Coefficient of Resistance (T.C.R) Natural resistance change per change in degree centigrade. $\frac{R_2 - R_1}{R_1(t_2 - t_1)} \times 10^6 \text{ (ppm/}^\circ\text{C)}$ $t_1 : 20^\circ\text{C}+5^\circ\text{C}-1^\circ\text{C}$ $R_1$ : Resistance at reference temperature (20°C+5°C/-1 °C) $R_2$ : Resistance at test temperature (-55°C or +125°C)	Refer to “ QUICK REFERENCE DATA “	
Short time overload (S.T.O.L) <b>IEC60115-1 4.13</b>	Permanent resistance change after a 5second application of a voltage 2.5 times RCWV or the maximum overload voltage specified in the above list, whichever is less.	±(0.1%+0.05Ω)	±(0.15%+0.05Ω)
Resistance to soldering heat(R.S.H) <b>MIL-STD-202 Method 210</b>	Un-mounted chips completely immersed for 10±1second in a SAC solder bath at 260°C±5°C	±(0.15%+0.05Ω)	±(0.25%+0.05Ω)
Solderability <b>IEC-60115-1 4.17</b>	Un-mounted chips completely immersed for 2±0.5 second in a SAC solder bath at 235°C±5°C	good tinning (>95% covered) no visible damage	
Temperature cycling <b>JESD22 method JA-104</b>	Test 1000 cycles (-55°C to +125°C),dwell time 30min. maximum. Measurement at 24±4 hours after test conclusion	±(0.25%+0.05Ω)	±(0.40%+0.05Ω)
Biased Humidity <b>MIL-STD-202 Method 103</b>	1000 +48/-0 hours, loaded with 10% rated power in humidity chamber controller at +85°C/85%RH	±(0.30%+0.05Ω)	±(0.50%+0.05Ω)
Operational Life <b>AEC-Q200-8 MIL-STD-202 -108</b>	1000 hours at 125±2°C, loaded with rated power cont inuously	±(0.30%+0.05Ω)	±(0.50%+0.05Ω)
High Temperature Exposure <b>MIL-STD-202 Method 108</b>	1000 hours @ +125°C, un-powered	±(0.25%+0.05Ω)	±(0.4%+0.05Ω)
Moisture Resistance <b>AEC-Q200 -6 MIL-STD-202 Method 106</b>	65±2°C, 80~100% RH, 10 cycles, 24 hours/ cycle	±(0.25%+0.05Ω)	
Mechanical Shock <b>MIL-STD-202 Method 213</b>	1/2 Sine Pulse / 100g Peak / Normal duration 6	±(0.2%+0.05Ω)	
Vibration <b>MIL-STD-202 Method 204</b>	5 g's for 20 min , 12 cycles each of 3 orientations	±(0.2%+0.05Ω)	
Terminal strength <b>AEC-Q200-006</b>	1.8 kg for 60 s	No broken	
Board flex <b>AEC-Q200-005</b>	Bending 2mm for 60 sec	±(0.2%+0.05Ω)	

## PACKAGING

Paper Tape specifications (unit :mm)

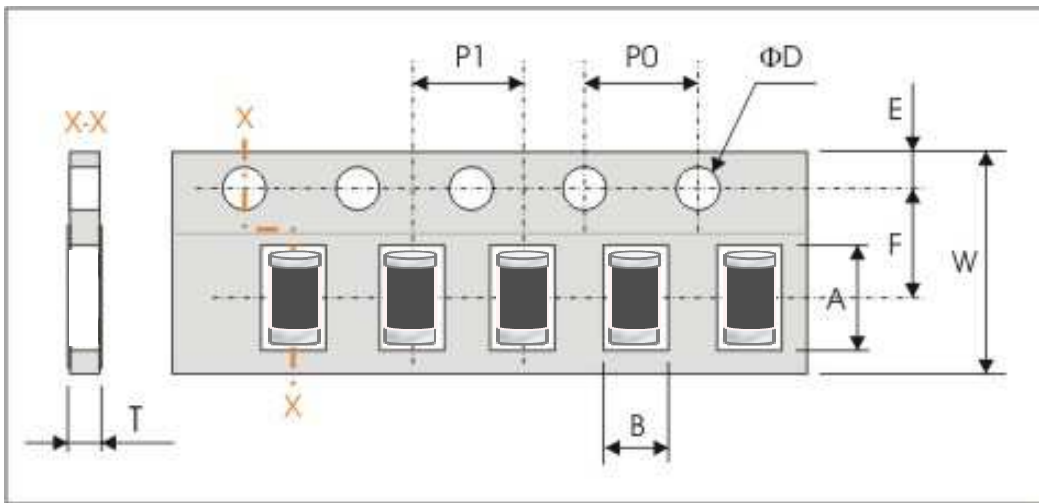

Series No.	A	B	W	E	F
WM07	6.15±0.10	2.40±0.10	12.0±0.10	1.75±0.10	5.50±0.05
WM04	3.65±0.10	1.55±0.10	8.0±0.10	1.75±0.10	3.50±0.05

Series No.	P0	P1	P2	ΦD0	T
WM07	4.00±0.10	4.00±0.10	2.00±0.05	1.50±0.05	2.70±0.1
WM04	4.00±0.10	4.00±0.10	2.00±0.05	1.50±0.05	1.80±0.1

### Reel dimensions

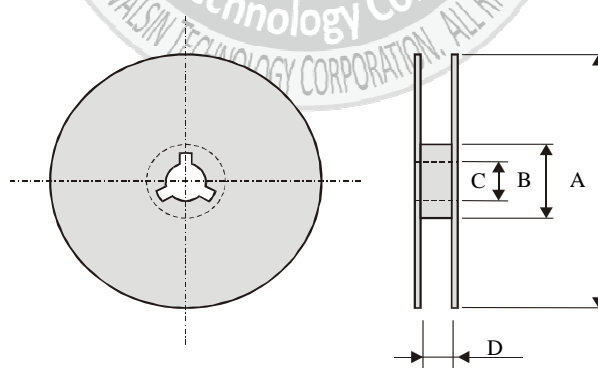

Symbol	A	B	C	D
0207	Φ178.0±2.0	Φ60.0±1.0	13.0±0.5	13.0±0.5
0204	Φ178.0±2.0	Φ60.0±1.0	13.0±0.2	9.0±0.5

### Taping quantity

- Cylinder resistors 2,000 pcs per reel ( WM07 )
- Cylinder resistors 3,000 pcs per reel ( WM04 )

**PULSE LOAD PERFORMANCE:**

**Single Pulse :**

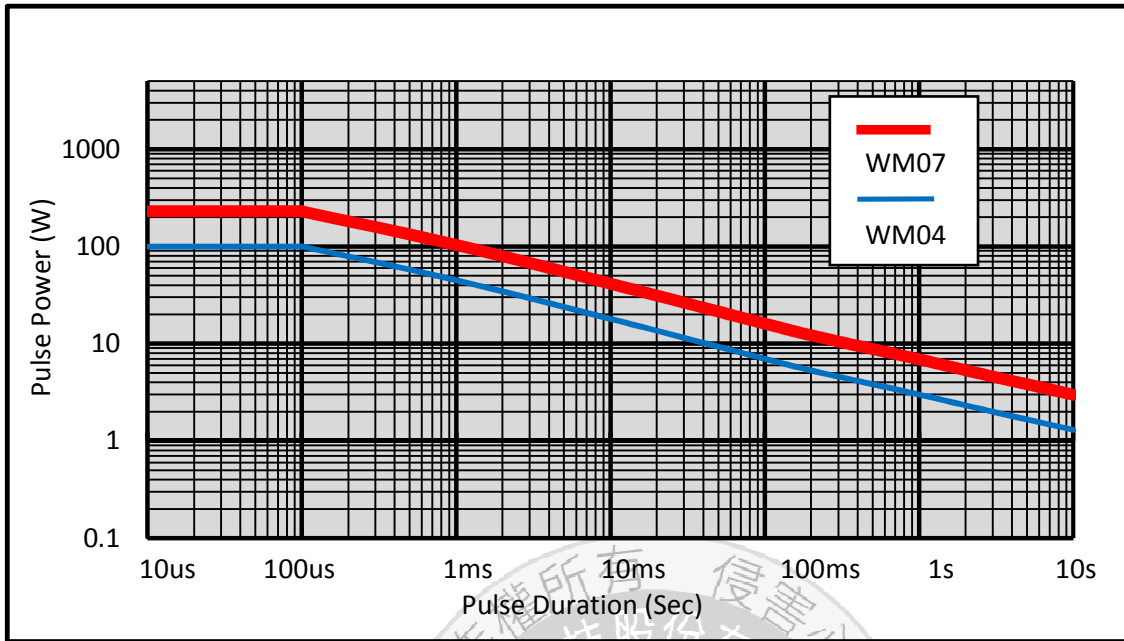

**Single Pulse for  $R \geq 10 \Omega$**

1000 rectangular pulse amplitudes are applied to the component at intervals of 60seconds, permissible the resistance to be varied by  $\pm (0.5\% R + 0.01\Omega)$ .

**Continuous Pulse :**

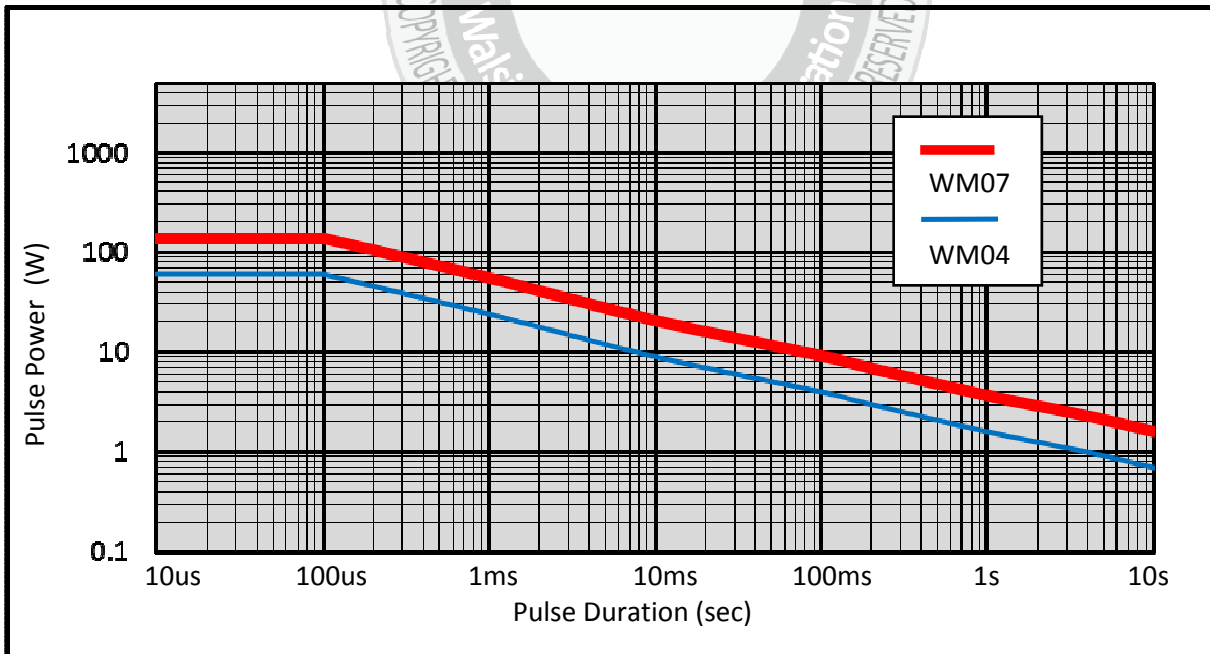

**Continuous Pulse for  $R \geq 10 \Omega$**

Continuous load is a pulse period generated by the repetitive rectangular pulse amplitude, the applied power dissipation is at a rated power of 70 °C.

Permissible the resistance to be varied by  $\pm (0.5\% R + 0.01\Omega)$ .

**Pulse Voltage :**

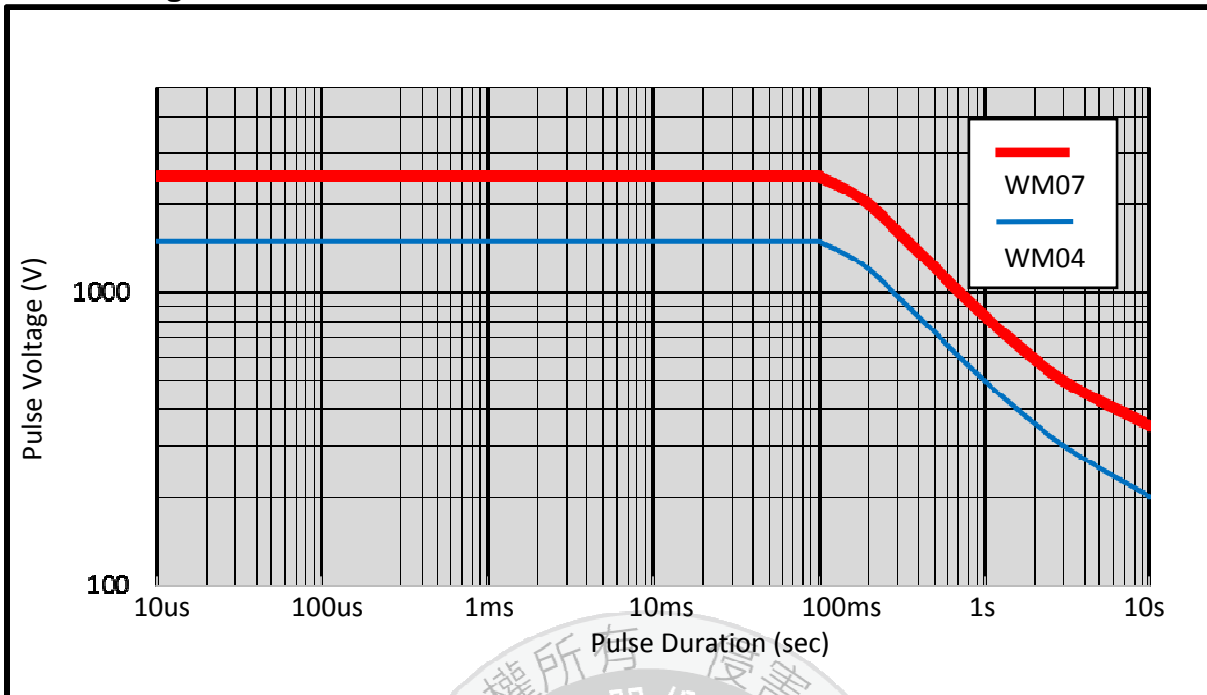

**Pulse Surge Overload :**

**1.2 / 50us Pulse**

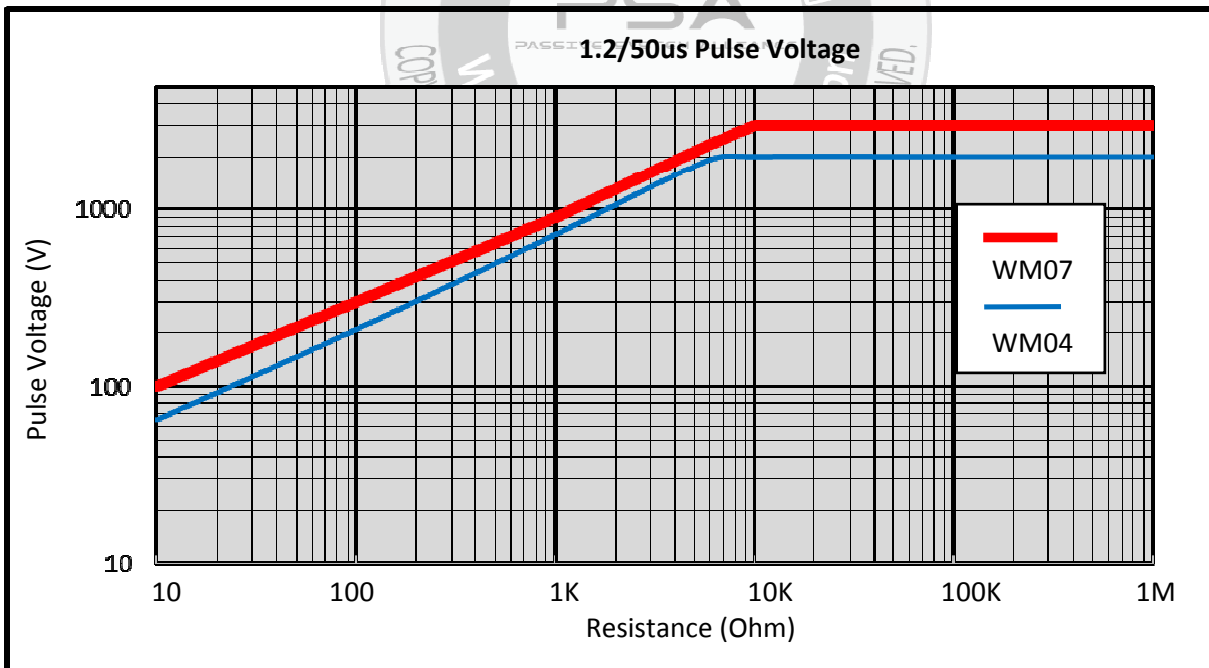

According to IEC 60115-1 4.27 1.2 / 50us use 5 pulses at 12sec intervals pulse shapes test resistor, permissible the resistance to be varied by  $\pm (0.5\% R + 0.01\Omega)$ .

### 10 / 700us Pulse

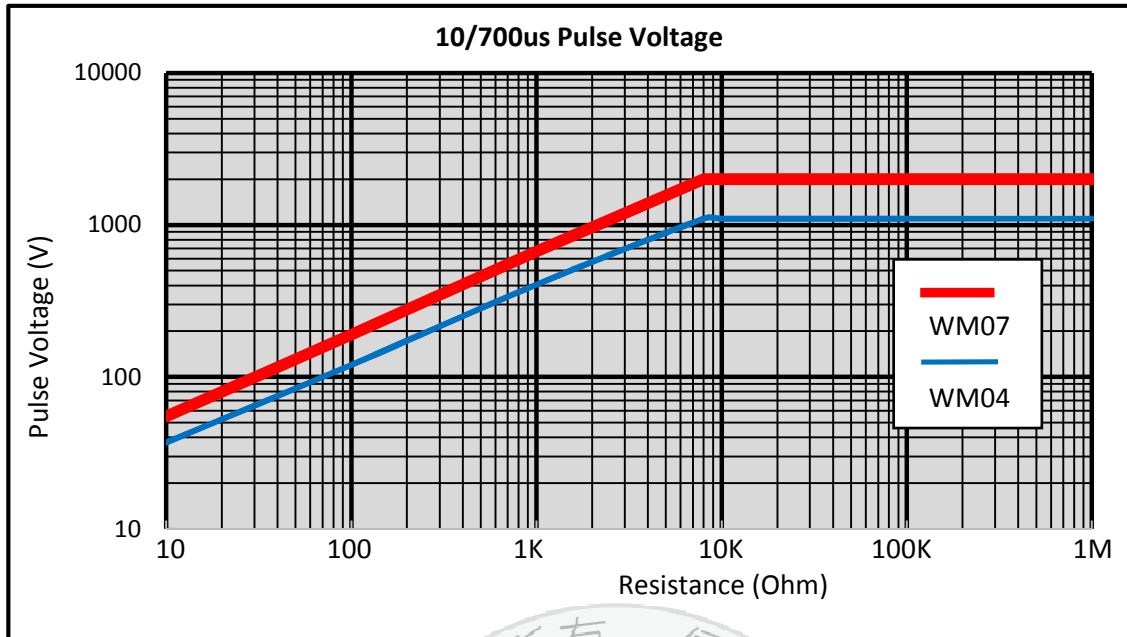

According to IEC 60115-1 4.27 10 / 700us use 10 pulses at 60sec intervals pulse shapes test resistor, permissible the resistance to be varied by  $\pm (0.5\% R + 0.01\Omega)$ .

