

PC915

Wide Band Linear Output Type OPIC Photocoupler

■ Features

1. Wide band linear output type
(Frequency band width : TYP. 10Hz to 8MHz)
2. Fluctuation free stable output
(Output fluctuation : TYP. $\pm 5\%$ at within operating temperature 50 000hr)
3. High isolation voltage
(V_{iso} : 5 000V_{rms})
4. Standard dual-in-line package
5. Recognized by UL, file No, E64380

■ Applications

1. Video signal insulation in TV
2. Insulation amplifier in measuring instrument and FA equipment

■ Outline Dimensions

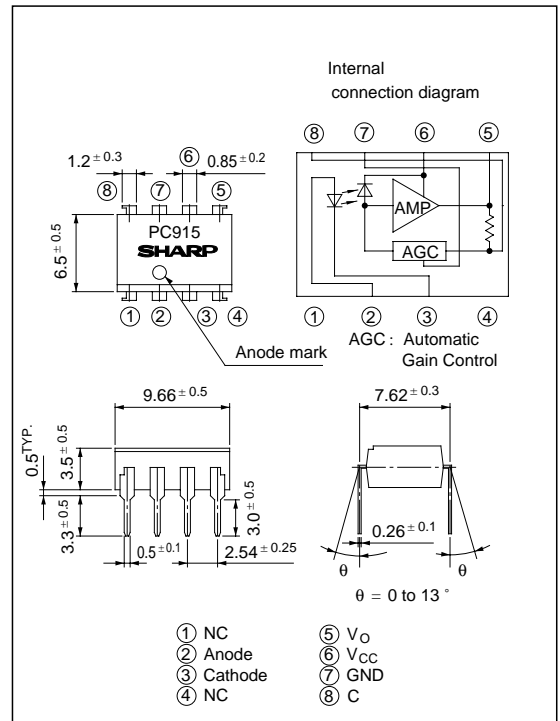

* "OPIC" (Optical IC) is a trademark of the SHARP Corporation.
 An OPIC consists of a light-detecting element and signal-processing circuit integrated onto a single chip.

■ Absolute Maximum Ratings

($T_a = 25^\circ\text{C}$)

Parameter		Symbol	Rating	Unit
Input	Forward current	I_F	25	mA
	Reverse voltage	V_R	6	V
	Power dissipation	P	45	mW
Output	Supply voltage	V_{CC}	- 0.5 to + 13	V
	Output power dissipation	P_O	250	mW
	Output current	I_O	- 1.0 to + 0.5	mA
*1 Isolation voltage		V_{iso}	5 000	V _{rms}
Operating temperature		T_{opr}	- 25 to + 85	$^\circ\text{C}$
Storage temperature		T_{stg}	- 55 to + 125	$^\circ\text{C}$
*2 Soldering temperature		T_{sol}	260	$^\circ\text{C}$

*1 40 to 60% RH, AC for 1 minute

*2 For 10 seconds

■ Electro-optical Characteristics

(Unless otherwise specified, Ta = 25°C)

Parameter		Symbol	Conditions	MIN.	TYP.	MAX.	Unit	Fig.	
Input	Forward voltage	V _F	I _F = 10mA	-	1.6	1.8	V	1	
	Reverse voltage	I _R	V _R = 5V	-	-	10	μA	-	
	Terminal capacitance	C _t	V = 0, f = 1MHz	-	60	250	pF	-	
Output	Supply current	I _{CC}	I _F = 10mA	-	9	16	mA	1	
	DC output voltage	V _{ODC}	I _F = 10mA	4	6	8	V	1	
	Output noise voltage	V _{ONO}	I _F = 10mA, Band width = 100Hz to 4.2MHz	-	4	-	mV _{rms}	1	
Transfer characteristics	AC output voltage		V _{OAC}	R _E = 230Ω	0.8	1.0	1.2	V _{P-P}	2
	AC output voltage fluctuation	*1 Temperature characteristics	ΔV _{OAC-1}	R _E = 230Ω, Ta = 10 to 70°C	-	± 3	-	%	2
		*2 Forward current characteristics	ΔV _{OAC-2}	R _E = 230 to 460Ω	-	± 3	-	%	2
	*3 Cut-off frequency	High frequency	f _{CH}	R _E = 230Ω	6	8	-	MHz	2
		Low frequency	f _{CL}	R _E = 230Ω	-	10	20	Hz	2
	Differential gain		DG		-	+ 3	-	%	3
	Differential phase		DP		-	- 3	-	°	3
	Isolation resistance		R _{ISO}	DC500V, 40 to 60% RH	5 × 10 ¹⁰	1 × 10 ¹¹	-	Ω	-
Floating capacitance		C _f	V = 0, f = 1MHz	-	0.6	5	pF	-	

*1 Fluctuation ratio of V_{OAC} at Ta = - 10 to 70°C on the basis of V_{OAC} at Ta = 25°C

*2 Fluctuation ratio of V_{OAC} at R_E = 230 to 460Ω on the basis of V_{OAC} at R_E = 230Ω

*3 Frequency of V_{IN} when V_{OAC} falls by 3dB on the basis of V_{OAC} when frequency of V_{IN} in Fig. 2 is 100kHz.

■ Recommended Operating Conditions

Parameter		Symbol	MIN.	MAX.	Unit
Input	Forward bias current	I _{FB}	8	15	mA
	Supply voltage	V _{CC}	8	13	V
Output	AC output voltage	V _{OAC}	-	4	V _{P-P}
	Output current	I _O	- 0.6	+ 0.2	mA
	C terminal capacitance	C _C	10	-	μF

■ Test Circuit

Fig.1

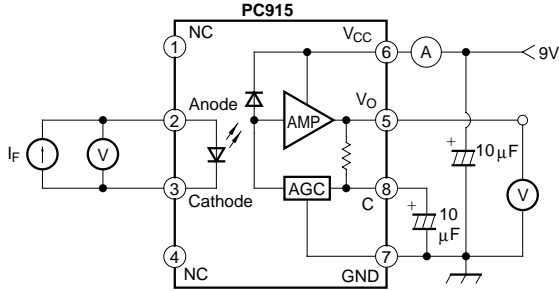
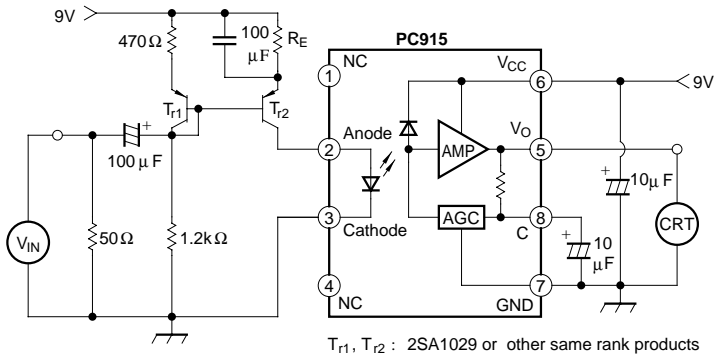

Fig. 2



V_{IN} Waveform



(Frequency) 15kHz at measuring V_{OAC} , ΔV_{OAC-1} and ΔV_{OAC-2}
and shall be swept at measuring f_{CH} and f_{CL} .

Fig. 3

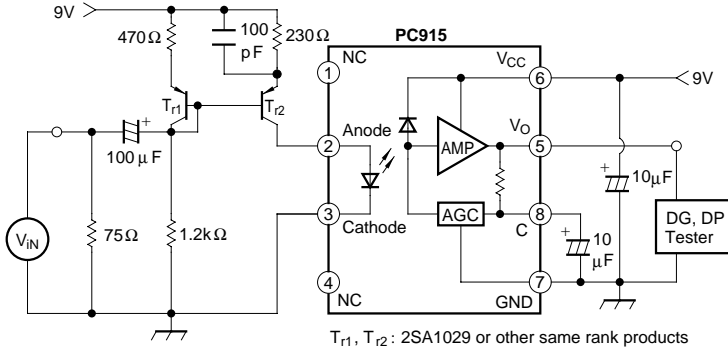

V_{IN} Waveform

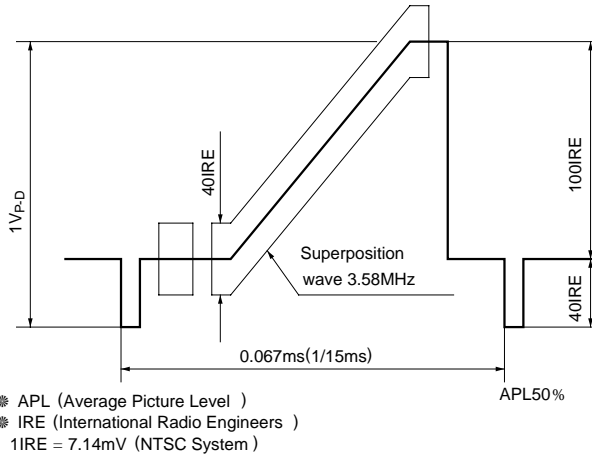

Fig. 4 Forward Current vs. Ambient Temperature

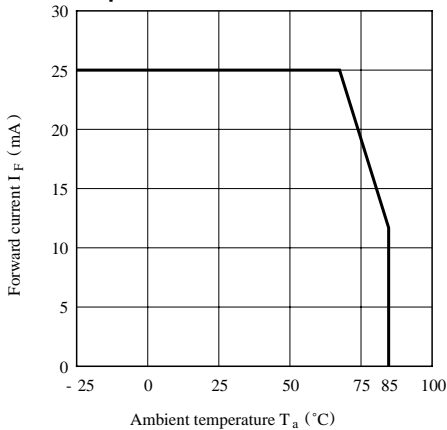

Fig. 5 Power Dissipation vs. Ambient Temperature

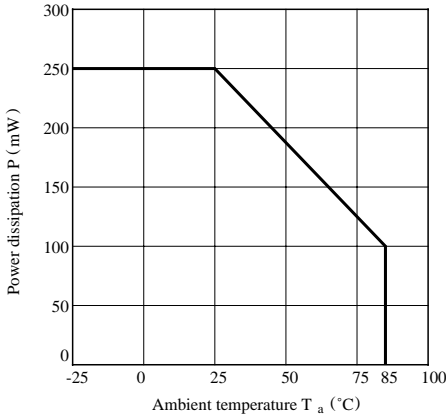

Fig. 6 Forward Current vs. Forward Voltage

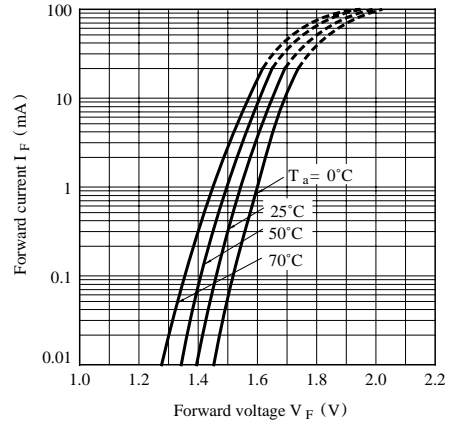

Fig. 7 Supply Current vs. Ambient Temperature

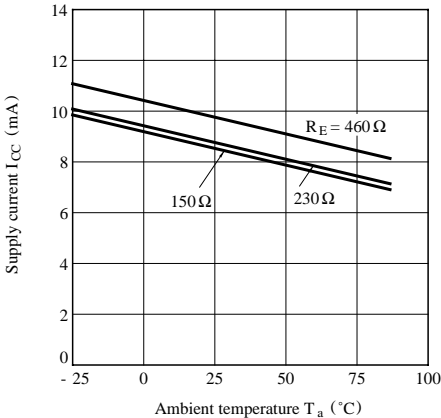
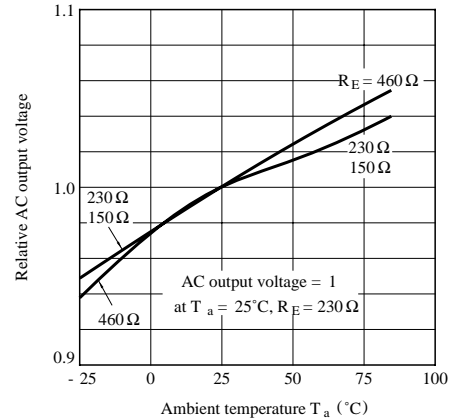
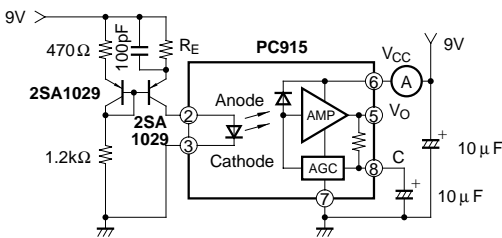

Fig. 8-a Relative AC Output Voltage 1 vs. Ambient Temperature



Test Circuit of Supply Current



Test Circuit of Relative AC Output Voltage 1 vs. Ambient Temperature

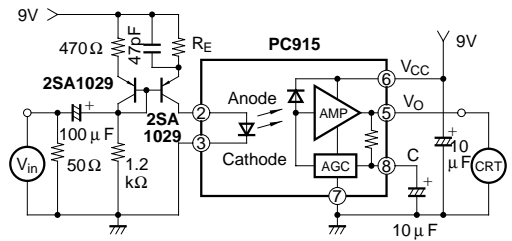

V_{in} Input Waveform



Fig. 8-b Relative AC Output Voltage 2 vs. Frequency (1)

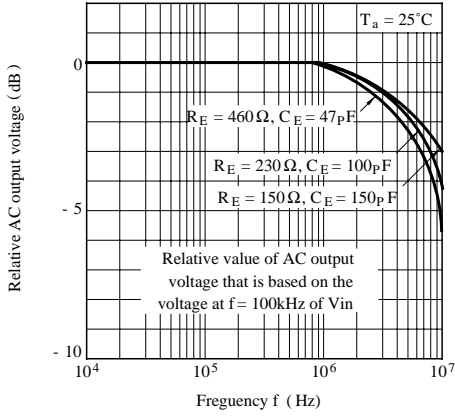

Test Circuit of Relative AC Output Voltage 2 vs. Frequency (1)

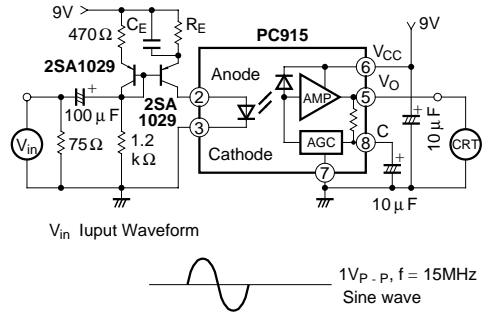
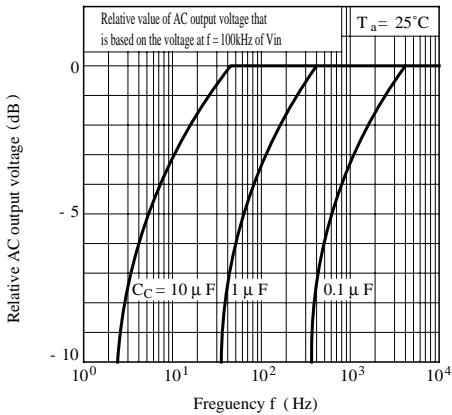

Fig. 8-c Relative AC Output Voltage 2 vs. Frequency (2)



Test Circuit of Relative AC Output Voltage 2 vs. Frequency (2)

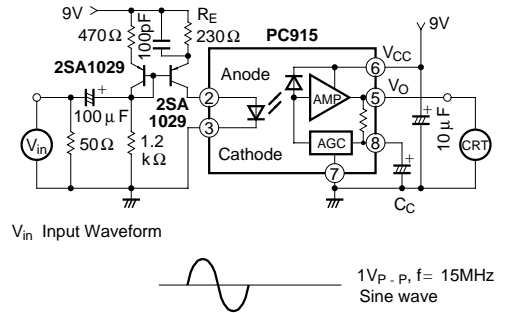

Fig. 9 Differential Gain vs. RE

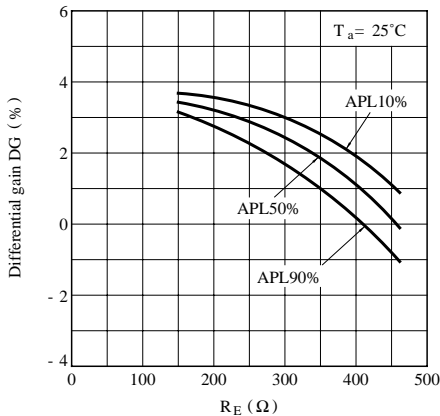
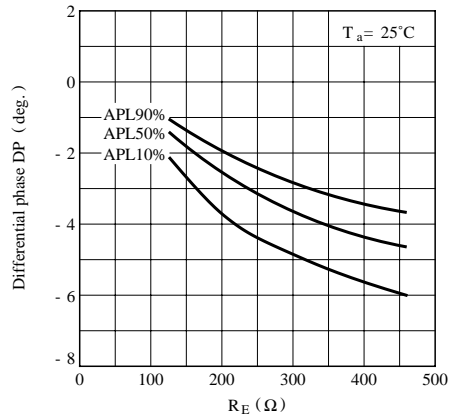
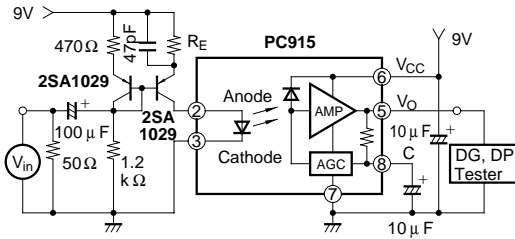

Fig.10 Differential Phase vs. RE



Test Circuit of Differential Gain vs. R_E and Differential Phase vs. R_E



V_{in} Waveform

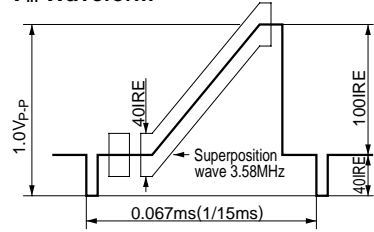

APL: Average Picture Level

Application Example

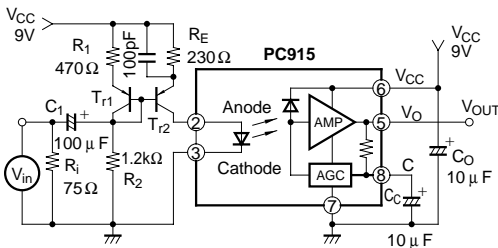

T_{r1}, T_{r2} : 2SA1029 or other same rank products

$$V_{OUT} = 2.3 \frac{I_s}{I_B} = 2.3 \frac{V_{in}}{V_{CC} - V_E}$$

I_B : DC flowed to infrared LED

I_s : AC flowed to infrared LED

V_E : Emitter voltage of T_{r2} (Between emitter and GND)

< Example of Circuit Setting >

(1) Set for Gain

Gain is represented by the following formula ;

$$G = 2.3 / (V_{CC} - V_E)$$

When using on condition that Gain = 1, set $V_{CC} - V_E$ on 2.3V. So that R_1 and R_2 is determined.

(2) Set for Input Resistance

Set R_i on output impedance (usually 75Ω) of a mounting equipment.

(3) Set for R_E

When there is no signal (input signal : 0), set I_{LED} flowed into infrared LED on 10 mA.

(4) Set for Low Cut-off Frequency

Low cut-off frequency with C terminal capacitance, C_c , is represented by the following formula;

$$f_c = 100 / C_c (\text{Hz}) (C_c : \mu\text{F value})$$

Then set C_i with input impedance of by-pass diode on as much value as possible on condition that $f_c > 1 / (2\pi C_i R) [R = R_1 R_2 / (R_1 + R_2)]$

Precautions for Use

- (1) It is recommended that a by-pass capacitor of more than $0.01\mu\text{F}$ is added between V_{CC} and GND near the device in order to stabilize power supply line.
- (2) Handle this product the same as with other integrated circuits against static electricity.
- (3) As for other general cautions, refer to the chapter "Precautions for Use"