

DESCRIPTION

The LXMG1800_LS Ambient Light Sensor Board Assembly provides a 'plug-n-play' automatic lamp dimming solution. It is designed particularly to mate with Microsemi's LXMG1811-05-6xS (5V input) and LXMG1813-12-6xS (8.4V to 16V) single lamp CCFL inverters.

Using the included wire harness and connector the LXMG1800_LS will plug into connector CN2 of the CCFL inverter and provide an automatic dimming solution based on ambient lighting conditions. This saves the time and effort needed to properly integrate this feature with an inverter.

The board is designed to sense light through a hole in the bottom of the board assembly so it can be easily flush mounted against the back of the display housing. Ambient light can then be directed to the sensor through a small hole in the display bezel, a panel mounted light pipe, or transparent or translucent opening in the display housing.

The board comes preprogrammed to drive the minimum inverter lamp brightness at complete darkness and full brightness when about 120 lux strikes the sensor. However the gain that determines this range is user adjustable both up or down by adding or removing solder bridge(s) to short jumpers J1 to J3 on the board. There are eight gain settings possible to tailor the sensor board to match a wide variety of lighting configurations.

In addition connecting an external 500k rheostat to the inverter's BRITE input pin will override the sensor output allowing further dimming. This rheostat (or a selected fixed resistor) could also be used to shift the sensor's range down thus trimming the gain.

The small size of the sensor board permits mounting it in the typically narrow space in the housing surrounding the LCD display. The length of the included wire harness (about 16") allows flexible mounting of the sensor with respect to the inverter mounting location.

IMPORTANT: For the most current data, consult MICROSEMI's website: <http://www.microsemi.com>

KEY FEATURES

- Save Energy By Automatically Adjusting Display Brightness to Meet Ambient Light Conditions
- Uses Microsemi's LX1974 Ambient Light Detector
- Plug-in Automatic Dimming
- Rated From -30°C to 80°C
- Size 31mm x 9.5mm x 2.5mm
- Easy Flush Mounting Against Display Bezel
- Includes 16" Leads For Flexible Mounting in System
- User Programmable Gain Settings
- Compatible With Microsemi's Single Lamp Inverters:
LXMG1811-05-6xS
LXMG1813-12-6xS

APPLICATIONS

- Single Lamp CCFL LCD Displays
- Portable Instrumentation Displays
- Medical Instrument Displays

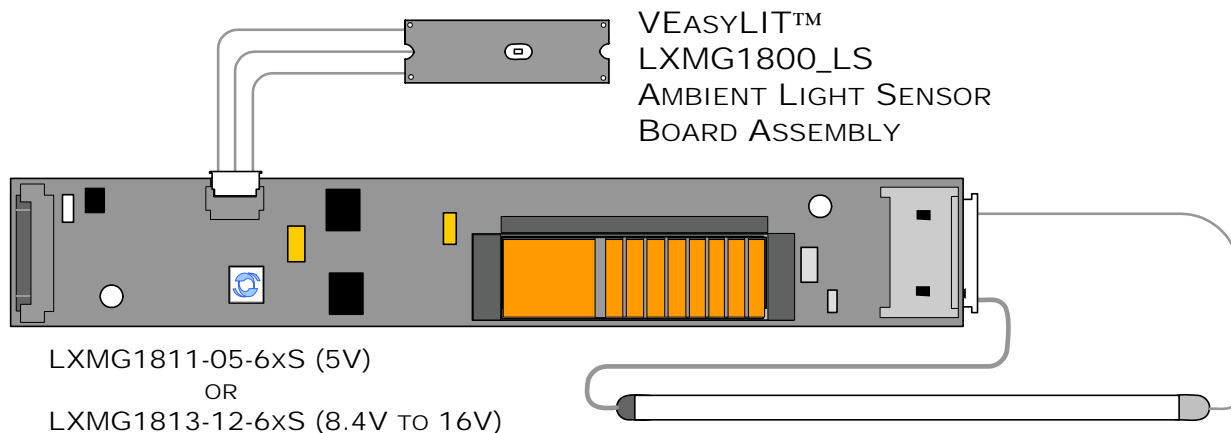
PRODUCT HIGHLIGHT

ORDER INFORMATION

RoHS Compliant	Matching Microsemi Inverters
LXMG1800_LS	LXMG1811-05-61S or LXMG1811-05-62S
	LXMG1813-12-61S or LXMG1813-12-62S



ABSOLUTE MAXIMUM RATINGS

Input Signal Voltage (ALS_VCC)	-0.3V to 6V
Output Voltage (ALS_OUT)	-0.3V to 5.5V
Ambient Operating Temperature, zero airflow	-30°C to 80°C
Storage Temperature Range	-40°C to 85°C

Exceeding these ratings could cause damage to the device. All voltages are with respect to Ground. Currents are positive into, negative out of specified terminal.

ELECTRICAL CHARACTERISTICS

Unless otherwise specified, the following specifications apply over the operating ambient temperature of 0°C < Temp < 60°C, and the following test conditions: ALS_VCC = 5V; J₁ = Short, J₂, J₃ = OPEN (Factory Setting)

Parameter	Symbol	Test Conditions / Comment	LXMG1800_LS			Units
			Min	Typ	Max	
ALS_OUT						
Peak Spectral Response	λ _{PR}			520		nm
Input irradiance which produces maximum ALS_OUT voltage	E _{V0}	J ₁ , J ₂ , J ₃ = OPEN	4.4	5.8	7.3	μW/cm ²
Input irradiance which produces maximum ALS_OUT voltage	E _{V1}	J ₁ = Short, J ₂ , J ₃ = OPEN (Factory Setting)	13.2	17.5	22	μW/cm ²
Input irradiance which produces maximum ALS_OUT voltage	E _{V2}	J ₂ = Short, J ₁ , J ₃ = OPEN	26.3	35	43.8	μW/cm ²
Input irradiance which produces maximum ALS_OUT voltage	E _{V3}	J ₃ = Short, J ₁ , J ₂ = OPEN	49.3	65.7	82	μW/cm ²
Input irradiance which produces maximum ALS_OUT voltage	E _{V4}	J ₁ , J ₂ , J ₃ = Short	78.8	105	131.4	μW/cm ²
Maximum output voltage produced at ALS_OUT	V _{BRITE_D}	ALS_VCC = 4.5V to 5.5V Load = 499K; 120 lux	2.1		2.8	V
Minimum voltage produced at ALS_OUT	V _{BRITE_D}	ALS_VCC = 4.5V to 5.5V Load = 499K; 0 lux	0.6		0.8	V

Note: The input irradiance (E_V) is supplied from a white light-emitting diode (LED) optical source adjusted to impose the specified E_V at a peak λ = 550nm. (For further details regarding irradiance vs. lux, see the LX1974 datasheet at: <http://www.microsemi.com>)

FUNCTIONAL PIN DESCRIPTION

Name	Pin #	Description
CN1		
CN1-1	ALS_VCC	Main Input Power Supply (Supplied through the inverter board) 4.5V to 5.5V
CN1-2	ALS_OUT	Light sensor board output supplied to inverter for brightness control
CN1-3	ALS_GND	Light sensor board ground connected to inverter ground

JUMPER GAIN SETTINGS

J1	J2	J3	Gain Factor	Description
OPEN	OPEN	OPEN	3.01	Highest Gain
SHORT	OPEN	OPEN	1.00	Nominal Factory Setting
OPEN	SHORT	OPEN	0.50	
SHORT	SHORT	OPEN	0.38	
OPEN	OPEN	SHORT	0.25	
SHORT	OPEN	SHORT	0.21	
OPEN	SHORT	SHORT	0.18	
SHORT	SHORT	SHORT	0.16	Lowest Gain

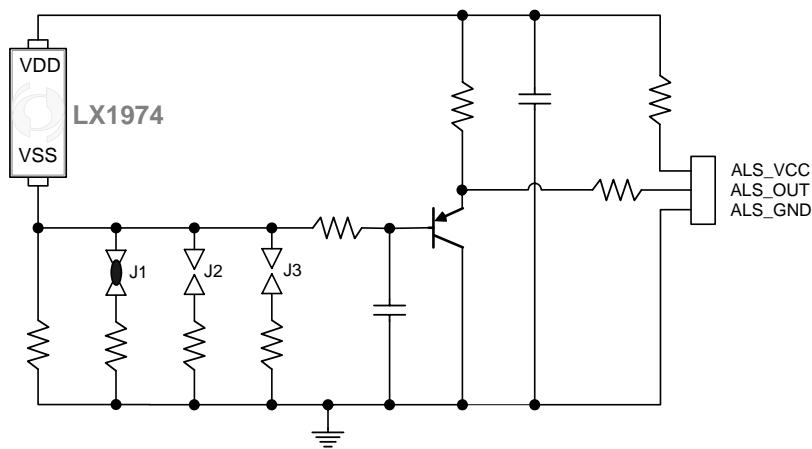
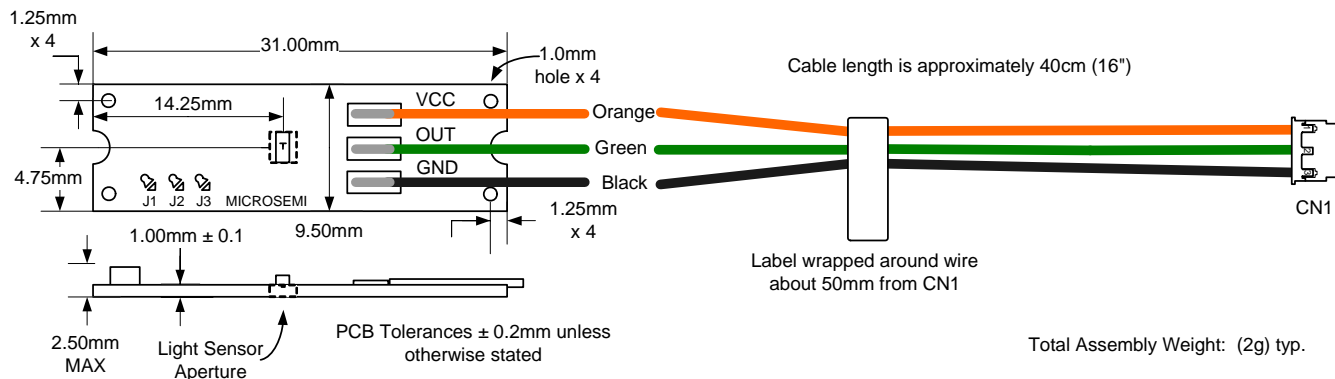
LXMG1800_LS SCHEMATIC

MECHANICAL DRAWING

APPLICATION INFORMATION
Adjusting the light gain, using jumpers J1 to J3:

The LXMG1800_LS comes from the factory preset with a solder bridge across jumper J1, as described in Jumper Gain Setting Table on page two. Light sensitivity will be reduced further by creating a solder bridge(s) across jumpers J2 or J3 or any combination. Reducing light sensitivity means that it will take a brighter light striking the sensor to signal the inverter to drive the panel to full brightness. Likewise if greater sensitivity is required (less light striking sensor to reach maximum lamp brightness) then the solder bridge on jumper J1 can be removed, using solder wick or vacuum removal tool. Which gain setting to use depends on the desired dimming range, ambient light conditions of the application and any loss in the light pipe or panel bezel used to supply light to the sensor assembly. The gain can also be trimmed downward by adding and adjusting a 500k rheostat, or selected fixed resistor to the inverter's BRITE input pin to ground.

Mounting Suggestions:

The sensor module may be mounted using one of three methods:

1. Use thin double-sided sticky tape with a hole punched in the tape to allow light to enter at the location of the light sensor, and then mounting the sensor against the back surface of the front panel.
2. Two small mounting screws on either end utilizing the half moon mounting holes; these half holes have a diameter of 2.5mm.
3. The four small 1mm holes in each corner could be hot melted down to small tabs molded into a plastic housing.

Light Aperture:

Generally the sensor should be mounted behind the LCD bezel frame in the same plane as the display. A small hole in the bezel or translucent frosted light opening that allows light to strike the sensor will suffice. Using only a hole may not be cosmetically attractive and could become plugged with dust or other contaminants. One option is to use a panel mounted light pipe to conduct the light to the surface of the sensor PCB. Further information on optical design can be found on our brief application note AN-32 'Optical Design of Ambient Light Sensor' which can be found at: <http://www.microsemi.com/micnotes/1404.pdf>



NOTES

PRODUCTION DATA – Information contained in this document is proprietary to Microsemi and is current as of publication date. This document may not be modified in any way without the express written consent of Microsemi. Product processing does not necessarily include testing of all parameters. Microsemi reserves the right to change the configuration and performance of the product and to discontinue product at any time.