

GENERAL DESCRIPTION

The SIC9653 is a high accuracy edge feedback LED constant current driver chip, suitable for 176 Vac ~ 265 Vac full range of input voltage, offering power under 7W flyback type isolation LED constant current power supply.

The SIC9653 was built in a high precision of sampling and compensation circuit, enables the circuit to achieve constant current accuracy around $\pm 3\%$. It also has excellent linear regulation and load regulation. Through the external R_{ADJ} pin, the resistor can easily control the LED open circuit protection voltage.

The SIC9653 has internal integration for 650V power MOSFET, design as original double winding feedback mode, it can work without secondary feedback circuit. It also doesn't need the compensation circuit. Combined with the precise and stable adaptive technology, it makes the system peripheral structure very simple with few peripheral devices. The wide range of parameters makes it easy to achieve high precision under condition of constant current control. Such design has greatly saving the system cost and size. At the same time it can ensure the consistency of the LED lamps and lanterns parameters during mass production.

The SIC9653 has many protection functions: output short circuit protection, sampling resistor short-circuit protection, under-voltage protection and output over-voltage protection, over temperature adaptive adjustment and etc.

FEATURES

- Internal integration 650V Power MOSFET
- $\pm 3\%$ LED Output Current Accuracy
- Original edge feedback constant current control, without secondary feedback circuits
- Without auxiliary winding and power supply
- LED open-circuit voltage adjusted through the external resistors
- Ultra-Low operating current
- Output short circuit protection
- Short open sampling resistance
- Output over-voltage protection
- Under-voltage protection
- Over-heat adaptive adjustment function
- Concise system topology with few peripheral devices
- Wide range of input voltage

TYPICAL APPLICATION

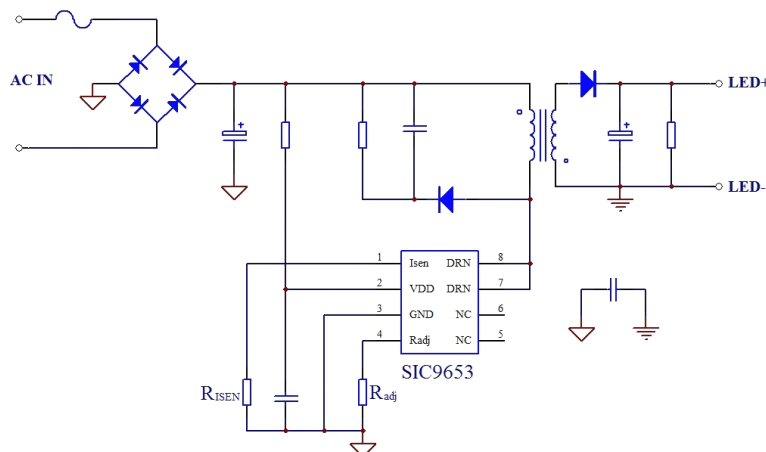



RECOMMENDED OPERATION CONDITIONS

Symbol	Parameters	Range	Unit
P _{OUT1}	Output power (output voltage 176-265V)	<7	W
P _{OUT2}	Output power (output voltage 85-265V)	<5	W
F _{OP}	System operating frequency	<100	KHz

ORDERING INFORMATION

Part number	Package	Package method	Marking
SIC9653	SOP-8	Tape 3,000PCS/Roll	SI 9653 YMXXXX

PIN CONFIGUTATION AND MARKING INFORMATION

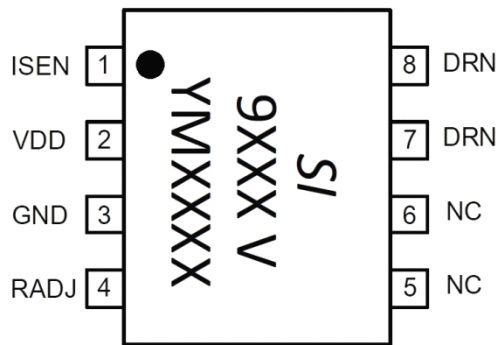

“SI”: Logo of SI Semiconductors

“9XXX V”:

9XXX: Product Model

V: Product Version

“YMxxx”

YM: Year/Month

XXXX: Batch Code

PIN DEFINITION

PIN NO.	Name	Description
1	ISEN	Current Sense Pin, external resistor to ground
2	VDD	Power Supply Pin
3	GND	Ground
4	RADJ	Open-circuit voltage protection, external resistor
5	NC	No Connection
6	NC	No Connection
7	DRN	Drain of internal MOSFET
8	DRN	Drain of internal MOSFET

ABSOLUTE MAXIMUM RATINGS

Parameters	Symbol	Range	Unit
Supply voltage	V _{DD}	-0.3-20	V
Drain voltage	V _{DRN}	-0.3-650	V
Sense voltage	V _{ISEN}	-0.3-6	V
Maximum operating current	I _{DDMAX}	5	mA
Open circuit protection voltage regulation	V _{RADJ}	-0.3-6	V



Maximum Power Dissipation($T_a=25^{\circ}\text{C}$)	P_{tot}	0.45	W
Thermal Resistance Junction-ambient	$R_{\text{thj-a}}$	145	$^{\circ}\text{C}/\text{W}$
Operating Junction Temperature	T_{J}	-40~150	$^{\circ}\text{C}$
Storage Temperature Range	T_{STG}	-55~150	$^{\circ}\text{C}$
ESD		2,000	V

Note: The Performance and reliability of the product will not be guaranteed in case of exceeding the limit parameter range. Exceeding of the limit parameter range should be avoid during practical using.

ELECTRICAL CHARACTERISTICS ($V_{\text{DD}}=15\text{V}$, $T_{\text{C}}=25^{\circ}\text{C}$)

Parameter	Symbol	Conditions	Range	Unit
V_{DD} clamp voltage	$V_{\text{DD_CLP}}$	1mA	16.1~17.9	V
working current	I_{DD}	$F_{\text{SYS}}=70\text{KHz}$	≤ 160	μA
starting voltage	V_{ST}	V_{DD} Rising	13.5~14.5	V
starting current	I_{ST}	$V_{\text{DD}}=V_{\text{ST}} - 1\text{V}$	≤ 100	μA
Under-voltage protection hysteresis	V_{UVLO}	V_{DD} Falling	8.5~9.5	V
Sampling reference voltage	V_{ISEN}		390~410	mV
Short circuit current detection threshold	$V_{\text{ISEN_SHT}}$	Output short	200	mV
Leading Edge Blanking Time for Current Sense	T_{LEB}		500	ns
Internal MOSFET turn-off delay	T_{DELAY}		200	ns
Drain-Source Breakdown Voltage of Internal MOSFET	BV_{DSS}	$V_{\text{GS}}=0\text{V}/ I_{\text{DS}}=250\mu\text{A}$	650	V
$R_{\text{DS(ON)}}$ of Internal MOSFET	$R_{\text{DS(ON)}}$	$V_{\text{GS}}=15\text{V}/ I_{\text{DS}}=0.2\text{A}$	< 16	Ω
Internal MOSFET Drain Leakage Current	I_{DSS}	$V_{\text{GS}}=0\text{V}/ V_{\text{DS}}=650\text{V}$	1	μA
RADJ Voltage on Pin	V_{RADJ}		0.5	V
Maximum conducting time	D_{MAX}		45	%
Maximum Demagnetization time	$F_{\text{SYS_MIN}}$		5	KHz
Minimum Demagnetization time	$F_{\text{SYS_MAX}}$		120	KHz
Over Heat Temperature	T_{REG}		155	$^{\circ}\text{C}$

INTERNAL BLOCK DIAGRAM

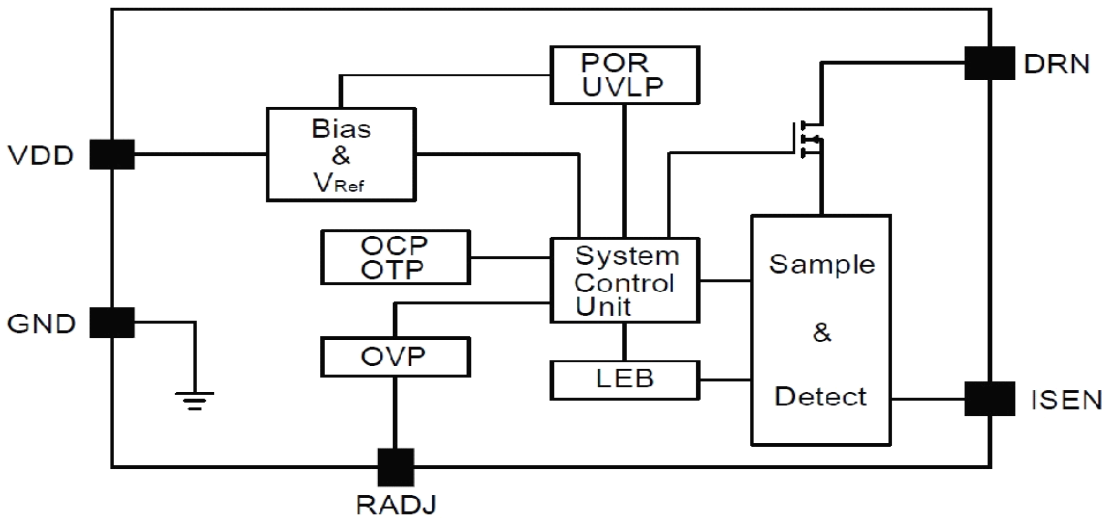

APPLICATION INFORMATION

Function Description

The SIC9653 is a constant current driver chip dedicated for LED Lighting applications. The device integrates a 650V high voltage MOSFET, operating under DCM mode and suitable for operating between 176-265V voltage ranges. With good linear regulation, load regulation and outstanding constant current characteristic, only using few peripheral components can also achieve low cost and high efficiency LED constant current controller.

The SIC9653 has adopted double winding feedback technology. It can operate without light coupling feedback, TL431 feedback and also power supply and auxiliary winding detection. The system has achieved low cost demand.

Start up

The starting current of the the SIC9653 is very low, after the system is powered on, V_{DD} starting resistance start charge the capacitance. When the V_{DD} reach the open threshold range, the circuit begins to work. When the SIC9653 is under normal operation condition, the internal circuit of the electric current can be as low as 50 μA, and internal system can offer an unique power mechanism. Thus, power supply can run normally without auxiliary winding supply.

Sampling resistance and constant current control

The SIC9653 works under the DCM mode, and it has a reference voltage of 400 mv inside. The reference voltage and inductance in the system compares the original edge peak current calculation. Through the adjustment of the sampling resistance, it is able to achieve the current control of LED driver:

$$I_{LED} = \frac{400}{4R_{ISEN}} \times \frac{N_P}{N_S} \text{ mA}$$

Note: I_{LED} is the LED drive current

R_{ISEN} is the sample resistance

N_P is the number of turns that winding around primary side of transformer

N_S is the number of turns that winding around secondary side of transformer

Operating frequency of the system

The SIC9653 system operates under DCM mode. Without the loop compensation its maximum space occupancy is 45%. In order to guarantee the operating stability of the system, the minimum working frequency was limited internal the chip. The maximum operating frequency of the chip recommendation is not to over than 100 KHZ. The system working frequency calculation formula goes to below:

$$f = \frac{N_p^2 \times V_{LED}}{8 \times N_s^2 \times L_p \times I_{LED}}$$

Note: L_p is Transformer primary side inductance

Over voltage protection

When designing the system, the open circuit voltage can be determined by turn ratios to the transformer. However, due to the various load requirements, different open circuit voltage protection requirements have brought inconvenience for the design of the transformer. Through the adjustment of an external resistor RADJ pin, the SIC9653 can achieved under the condition of reasonable design of transformer. By adjusting the external resistor RADJ pin open circuit protection voltage, the SIC9653 can adjust system without changing the transformer. Such design can not only do great benefit to the customer's system design, but also convenient for production and operations. Finally allows users to obtain better efficiency and effectiveness.

In the system, when the LED is on the open condition, due to no load connection, the output voltage will gradually rise, leading to the decrease of demagnetization time, therefore the RADJ through an external resistor can control the corresponding demagnetization time. It can also get open circuit voltage protection at the same time. Calculate according to the internal circuit, can draw RADJ relations with VOVP formula goes as:

$$R_{ADJ} \approx \frac{V_{ISEN} \times L_p \times 16}{R_{ISEN} \times N_{PS} \times V_{OVP}} \times 10^6 (Kohm)$$

Note: V_{ISEN} is ISEN turn off threshold value

L_p is the original side inductance

R_{ISEN} is the sample resistance

N_{PS} is the turns ratio of secondary side of transformer

V_{OVP} is The set value of over voltage protection

Protection Function

The SIC9552 has a variety of protective functions such as the LED to open/short circuit protection, I_{SEN} resistance short-circuit protection, V_{DD} over-voltage/under-voltage, temperature adaptive adjustment and etc.

When the SIC9552 is working, it is able to monitoring the various working status automatically. When the load turns to open, the circuit will enter a state of over-voltage protection, immediately shut the internal MOSFET will be shut down immediately and the system runs into interval detection at the

same time. After the recovery of the failure, circuit will automatically return to normal working state; if Load circuit runs into short situation, the system will work at around 5 KHZ state of low frequency, low power consumption, constantly monitoring the system at the same time. After the load circuit is back to normal condition, the circuit will also resume back to normal working status; In the situation of ISEN resistance short-circuit, or other failure such as inductor saturation, fast protection mechanism circuit will immediately stop the MOSFET switching action. Working circuit power supply will also be declined, at this point, when U_{VLO} circuit is triggered, the system will also restart. In summary, such design can realize the protection function of trigger and restart working mechanism.

During the working process, when the SIC9552 detected the circuit junction temperature runs over the temperature adjusting threshold (155 °C), the circuit will enter a state of a temperature adjusting control, reducing the output current to control the output power and rise of temperature. That can enable the system to maintain in the normal range of stable operating temperature.

PCB Layout

1. It's very critical for V_{DD} bypass capacitor, should be as close as possible to VDD and GND pin.
2. The area of main current loop should be as small as possible to reduce EMI radiation, such as the inductor, the output diode and the bus capacitor loop.
3. The power ground path should be separated from small signal ground path and shorten the distance with the capacitance.
4. R_{ADJ} external resistance need to be close to R_{ADJ} pins, and connected to the ground.
5. The NC pin(PIN3) should be connected to GND (pin1) , R_{ADJ} resistance will set to the ground if possible.
6. DRN pin (PIN5, PIN6) apply copper area should be as large as possible for better thermal dissipation. However too large copper area may compromise EMI performance.

SOP8 封装机械尺寸
SOP8 MECHANICAL DATA

单位:毫米/UNIT: mm

符号 SYMBOL	最小值 min	典型值 nom	最大值 max	符号 SYMBOL	最小值 min	典型值 nom	最大值 max
A	4.80		5.00	C	1.30		1.50
A1	0.37		0.47	C1	0.55		0.75
A2		1.27 TYP		C2	0.55		0.65
A3		0.41 TYP		C3	0.05		0.20
B	5.80		6.20	C4	0.19	0.20TYP	0.23
B1	3.80		4.00	D		1.05TYP	
B2		5.0TYP		D1	0.40		0.62

