

RS7213

300mA High Speed, Low Noise LDO with Fast Enable and Fast Discharge Function

General Description

The RS7213 series is a low-dropout linear regulator with ON/OFF control that operates in the input voltage range from +1.8V to +5.5V and delivers 300mA output current.

The fixed output voltage is preset at an internally trimmed voltage 1.8V, 2.5V, or 3.3V. Other options 1.0V, 1.2V, 1.5V, 2.2V, 3.0V and 3.6V are available by special order only.

The RS7213 consists of a 0.87V bandgap reference, an error amplifier, and a P-channel pass transistor. Other features include short-circuit protection, thermal shutdown protection, fast respond and fast discharge functions. The RS7213 series devices are available in SOT-25 & SC-70-5 packages.

Features

- Operating Voltage Range : +1.8V to +5.5V
- Output Voltages : +0.9V to +5.0V (0.1V Step)
- Dropout Voltage : 90mV@100mA (Typ.)
- Fast Response in Power-on Transient : 35µS (Typ.)
- Low Current Consumption : 30µA (Typ.)
- Shutdown Current : 0.7µA (Typ.)
- ±2% Output Voltage Accuracy (special ±1%highly accurate), $V_{OUT} \geq 1.8V$
- Low ESR Capacitor Compatible
- High Ripple Rejection : 70dB (Typ.)
- Output Current Limit Protection : 500mA (Typ.)
- Short Circuit Protection : 70mA (Typ.)
- Thermal Overload Shutdown Protection
- Control Output ON/OFF Function
- SOT-25 & SC-70-5 Packages
- RoHS Compliant and 100% Lead (Pb)-Free and Green (Halogen Free with Commercial Standard)

Applications

- Battery-powered equipment
- Voltage regulator for microprocessor
- Voltage regulator for LAN cards
- Wireless Communication equipment
- Audio/Video equipment
- Post Regulator for Switching Power
- Home Electric/Electronic Appliance
- CDMA/GSM Cellular Handsets
- Laptop, Palmtops, Notebook Computers
- Portable Information Application

Application Circuits

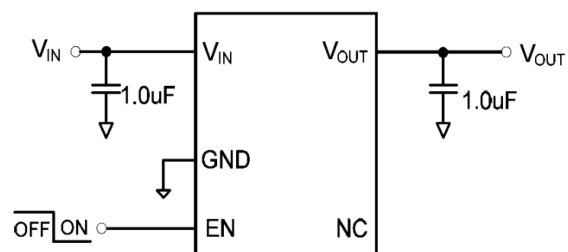
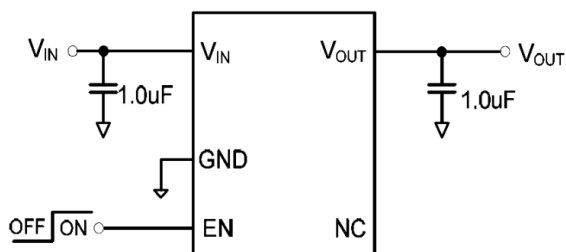

This integrated circuit can be damaged by ESD. Orister Corporation recommends that all integrated circuits be handled with appropriate precautions. Failure to observe proper handling and installation procedures can cause damage.

ESD damage can range from subtle performance degradation to complete device failure. Precision integrated circuits may be more susceptible to damage because very small parametric changes could cause the device not to meet its published specifications.

Pin Assignment

SOT-25

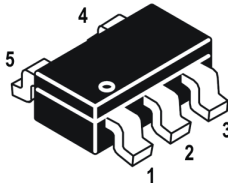

SC-70-5

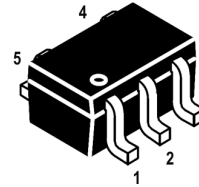

PACKAGE	PIN	SYMBOL	DESCRIPTION
SOT-25	1	VIN	Regulator Input Pin
	2	GND	Ground Pin
	3	EN	Chip Enable Pin
	4	NC	No Connection
	5	VOUT	Regulator Output Pin

PACKAGE	PIN	SYMBOL	DESCRIPTION
SC-70-5	1	VIN	Regulator Input Pin
	2	GND	Ground Pin
	3	EN	Chip Enable Pin
	4	NC	No Connection
	5	VOUT	Regulator Output Pin

Ordering Information

DEVICE	DEVICE CODE
RS7213-XX EEE YY Z	<p>XX is nominal output voltage (for example, 18 = 1.8V, 33 = 3.3V, 285 = 2.85V). EEE is CE Input Logic & Discharge Function Selection : (see CE & Discharge Function Selection Table) YY is package designator : NE : SOT-25 SC : SC-70-5 Z is Lead Free designator : P: Commercial Standard, Lead (Pb) Free and Phosphorous (P) Free Package G: Green (Halogen Free with Commercial Standard)</p>

CE & Discharge Function Selection Table

EEE CODE	EN Type		Discharge	EEE CODE	EN Type		Discharge
	Type 1	Type 2			Type 1	Type 2	
NHF	None	High Active	Fast	UHN	Pull High	High Active	Normal
NLF	None	Low Active	Fast	ULN	Pull High	Low Active	Normal
NHN	None	High Active	Normal	DHF	Pull Low	High Active	Fast
NLN	None	Low Active	Normal	DLF	Pull Low	Low Active	Fast
UHF	Pull High	High Active	Fast	DHN	Pull Low	High Active	Normal
ULF	Pull High	Low Active	Fast	DLN	Pull Low	Low Active	Normal

Block Diagram

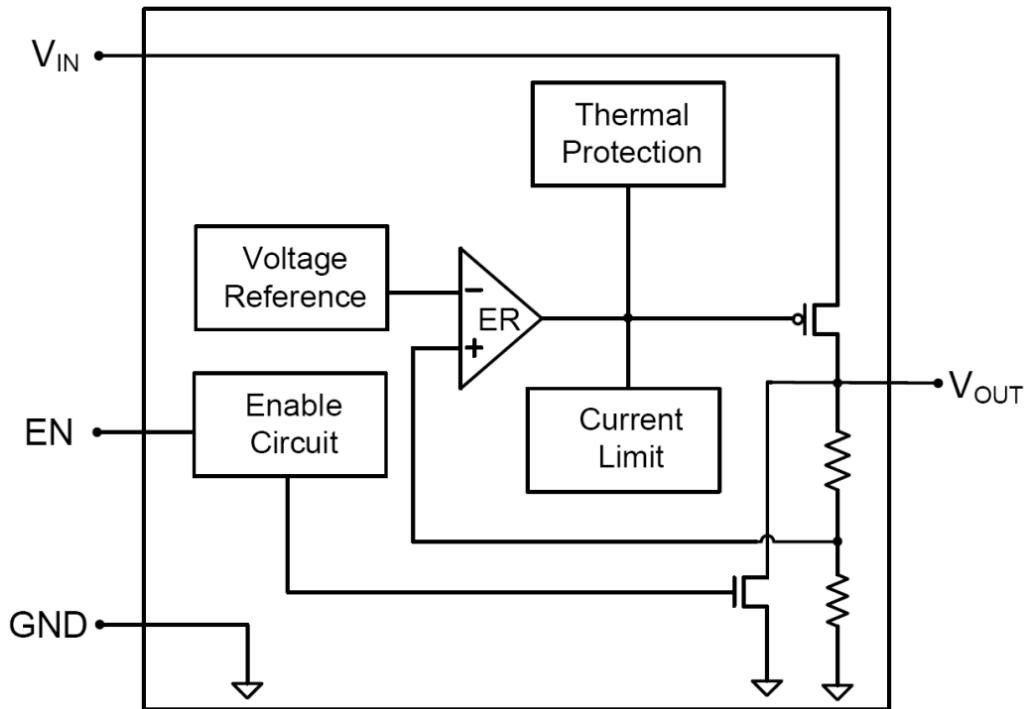

Absolute Maximum Ratings

Parameter		Symbol	Ratings	Units
Input Voltage V_{IN} to GND		V_{IN}	6.0	V
Output Current Limit, I_{LIMIT}		I_{LIMIT}	0.5	A
Junction Temperature		T_J	+155	°C
Thermal Resistance	SOT-25	θ_{JA}	250	°C/W
	SC-70-5		333	
Power Dissipation	SOT-25	P_D	400	mW
	SC-70-5		200	
Operating Ambient Temperature		T_{OPR}	-40 ~ +125	°C
Storage Temperature		T_{STG}	-55~+150	°C
Lead Temperature (soldering, 10sec)		-	+260	°C

NOTES :

- 1 The power dissipation values are based on the condition that junction temperature T_J and ambient temperature T_A difference is 100°C.
- 2 Stresses beyond those listed under “absolute maximum ratings” may cause permanent damage to the device. These are stress ratings only, and function operation of the device at these or any other conditions beyond those indicated under “recommended operating conditions” is not implied. Exposure to absolute-maximum –rated conditions for extended periods may affect device reliability.

Electrical Characteristics ($V_{IN}=5V$, $T_A=25^\circ C$, unless otherwise specified)

Symbol	Parameter	Conditions	Min.	Typ.	Max.	Unit
V_{IN}	Input Voltage	-	1.8	-	5.5	V
V_{OUT}	Output Voltage	$V_{IN}=V_{OUT}+1.0V$, $I_{OUT}=1mA$, $V_{OUT} \geq 1.8V$	-2%	V_{OUT}	+2%	V
		$V_{IN}=V_{OUT}+1.0V$, $I_{OUT}=1mA$, $V_{OUT} < 1.8V$, $V_{IN} > 2.4V$	-35		+35	mV
I_{MAX}	Output Current (see NOTE 1)	$V_{OUT}+1.0V \leq V_{IN} \leq 5.5V$, $V_{IN} \geq 2.4V$	300	-	-	mA
V_{DROP}	Dropout Voltage	$I_{OUT}=300mA$, $V_{OUT} > 2.0V$	-	300	500	mV
ΔV_{LINE}	Line Regulation	$V_{OUT}+1.0V \leq V_{IN} \leq 5.5V$, $I_{OUT}=1mA$	-	0.2	0.3	%/V
ΔV_{LOAD}	Load Regulation	$V_{IN}=V_{OUT}+1V$, $1mA \leq I_{OUT} \leq 100mA$	-	0.01	0.02	%/mA
I_Q	Ground Pin Current	$I_{LOAD}=0mA$ to $300mA$, $V_{IN}=V_{OUT}+1V$	-	30	50	μA
I_{SD}	Shutdown Current	$V_{IN}=V_{OUT}+1V$, $EN=0V$, No Load	-	0.7	1.0	μA
I_{SC}	Short Circuit Current	-	-	70	-	mA
PSRR	Ripple Rejection	$I_{OUT}=30mA$, $F=1KHz$, $C_{OUT}=1\mu F$	-	70	-	dB
e_N	Output Noise	$I_{OUT}=100mA$, $F=1KHz$, $C_{OUT}=1\mu F$	-	40	-	$\mu V_{(rms)}$
V_{IH}	EN Pin Input Voltage "H"	$V_{IN} \leq 5.0V$	1.6	-	-	V
V_{IL}	EN Pin Input Voltage "L"	$V_{IN} \leq 5.0V$	-	-	0.3	V
R_{DIS}	Discharge Resistor	$V_{EN}=0V$	-	30	100	Ω
T_{DIS}	Discharge Time	$V_{OUT}=3.3V$ to $0V$, $C_{OUT}=1\mu F$	-	70	100	μs
T_C	Temperature Characteristics	$I_{OUT}=1mA$, $-25^\circ C \leq T_{OPR} \leq +85^\circ C$	-	± 100	-	ppm/ $^\circ C$
T_{SD}	Thermal Shutdown Temperature	-	-	150	-	$^\circ C$
T_{HYS}	Thermal Shutdown Hysteresis	-	-	30	-	$^\circ C$

NOTES :

- 1 Measured using a double sided board with 1" x 2" square inches of copper area connected to the GND pins for "heat spreading".

Detail Description

The RS7213 is a low-dropout linear regulator. The device provides preset 1.8V, 2.5V and 3.3V output voltages for output current up to 300mA. Other mask options for special output voltages are also available. As illustrated in function block diagram, it consists of a 0.87V bandgap reference, an error amplifier, a P-channel pass transistor and an internal feedback voltage divider.

The bandgap reference for is connected to the error amplifier, which compares this reference with the feedback voltage and amplifies the voltage difference. If the feedback voltage is lower than the reference voltage, the pass transistor's gate is pulled lower, which allows more current to pass to the output pin and increases the output voltage. If the feedback voltage is too high, the pass transistor's gate is pulled up to decrease the output voltage.

The output voltage is feed back through an internal resistor divider connected to V_{OUT} pin. Additional blocks include an output current limiter, thermal sensor, and shutdown logic.

Internal P-channel Pass Transistor

The RS7213 features a P-channel MOSFET pass transistor. Unlike similar designs using PNP pass transistors, P-channel MOSFETs require no base drive, which reduces quiescent current. PNP-based regulators also waste considerable current in dropout when the pass transistor saturates, and use high base-drive currents under large loads. The RS7213 does not suffer from these problems and consumes only 30µA (Typ.) of current consumption under heavy loads as well as in dropout conditions.

Enable Function

EN pin starts and stops the regulator. When the EN pin is switched to the power off level, the operation of all internal circuit stops, the build-in P-channel MOSFET output transistor between pins V_{IN} and V_{OUT} is switched off, allowing current consumption to be drastically reduced. The V_{OUT} pin enters the GND level through the internal discharge path between V_{OUT} and GND pins.

Operating Region and Power Dissipation

Maximum power dissipation of the RS7213 depends on the thermal resistance of the case and circuit board, the temperature difference between the die junction and ambient air, and the rate of airflow. The power dissipation across the devices is P = I_{OUT} x (V_{IN}-V_{OUT}). The resulting maximum power dissipation is:

$$P_{MAX} = \frac{(T_J - T_A)}{\theta_{JC} + \theta_{CA}} = \frac{(T_J - T_A)}{\theta_{JA}}$$

Where (T_J-T_A) is the temperature difference between the RS7213 die junction and the surrounding air, θ_{JC} is the thermal resistance of the package chosen, and θ_{CA} is the thermal resistance through the printed circuit board, copper traces and other materials to the surrounding air. For better heat-sinking, the copper area should be equally shared between the V_{IN}, V_{OUT}, and GND pins.

The thermal resistance θ_{JA} of SOT-25 package of RS7213 is 250°C/W. Based on a maximum operating junction temperature 125°C with an ambient of 25°C, the maximum power dissipation will be:

$$P_{MAX} = \frac{(T_J - T_A)}{\theta_{JC} + \theta_{CA}} = \frac{(125 - 25)}{250} = 0.40W$$

Thermal characteristics were measured using a double sided board with 1"x2" square inches of copper area connected to the GND pin for "heat spreading".

Dropout Voltage

A regulator's minimum input-output voltage differential, or dropout voltage, determines the lowest usable supply voltage. In battery-powered systems, this will determine the useful end-of-life battery voltage. The RS7213 use a P- channel MOSFET pass transistor, its dropout voltage is a function of drain-to-source on-resistance R_{DS(ON)} multiplied by the load current.

$$V_{DROPOUT} = V_{IN} - V_{OUT} = R_{DS(ON)} \times I_{OUT}$$

SOT-25 Dimension

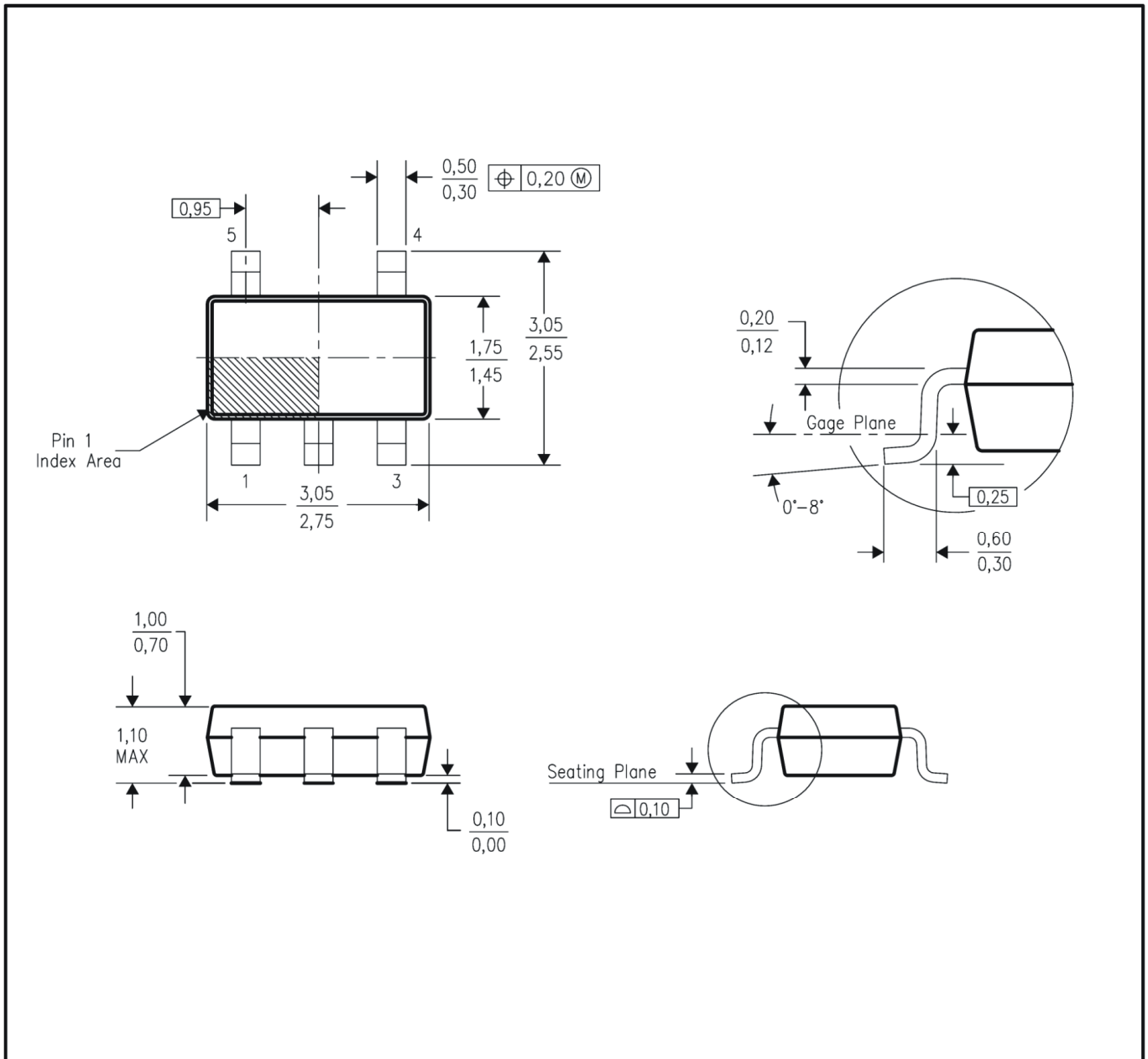

NOTES:

- All linear dimensions are in millimeters.
- This drawing is subject to change without notice.
- Body dimensions do not include mold flash or protrusion.
- Falls within JEDEC MO-193 variation AB (5 pin).

SC-70-5 Dimension

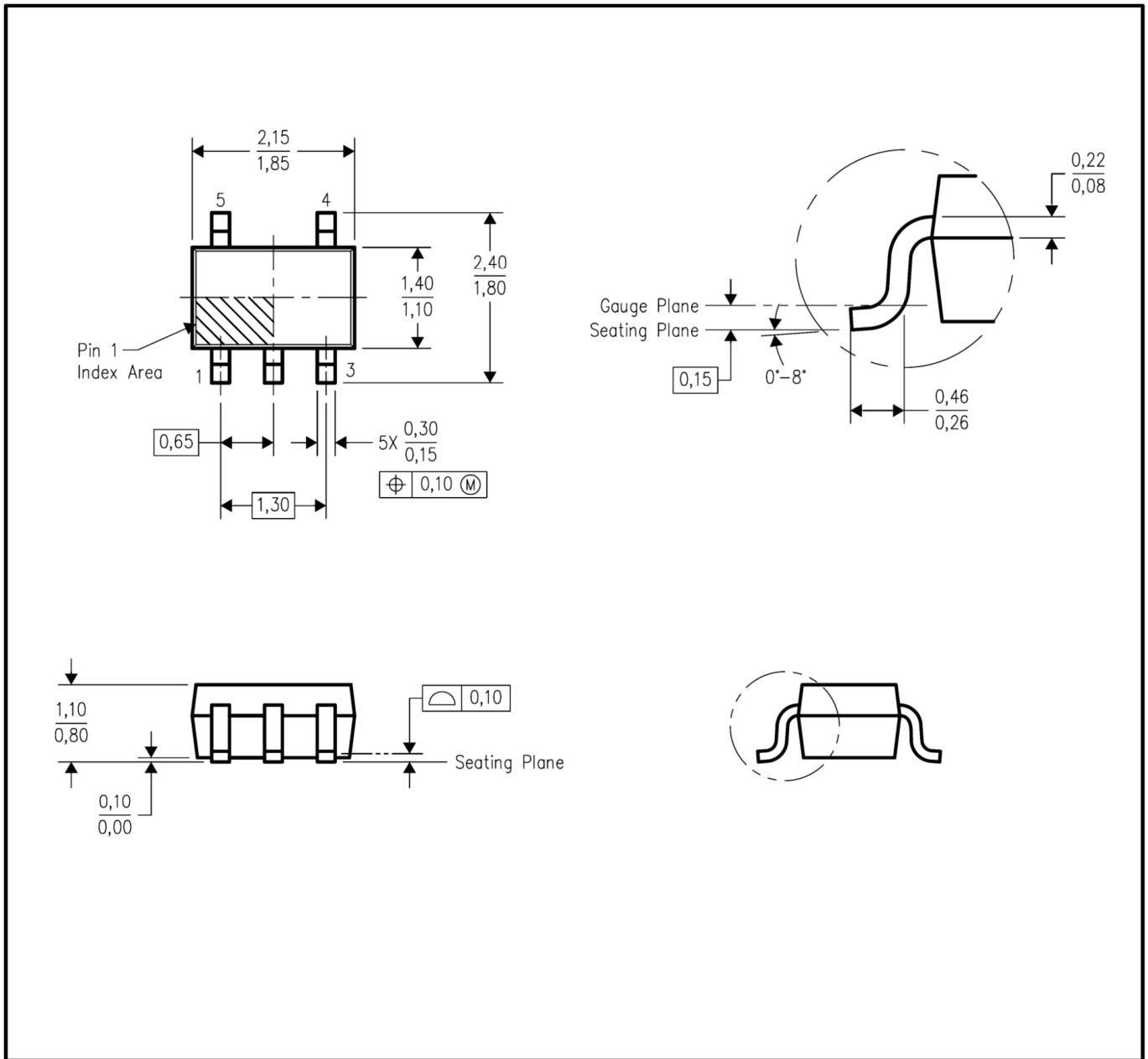

NOTES:

- All linear dimensions are in millimeters.
- This drawing is subject to change without notice.
- Body dimensions do not include mold flash or protrusion. Mold flash and protrusion shall not exceed 0.15 per side.
- Falls within JEDEC MO-203 variation AA.

Soldering Methods for Orister's Products

1. Storage environment: Temperature=10°C~35°C Humidity=65%±15%
2. Reflow soldering of surface-mount devices

Figure 1: Temperature profile

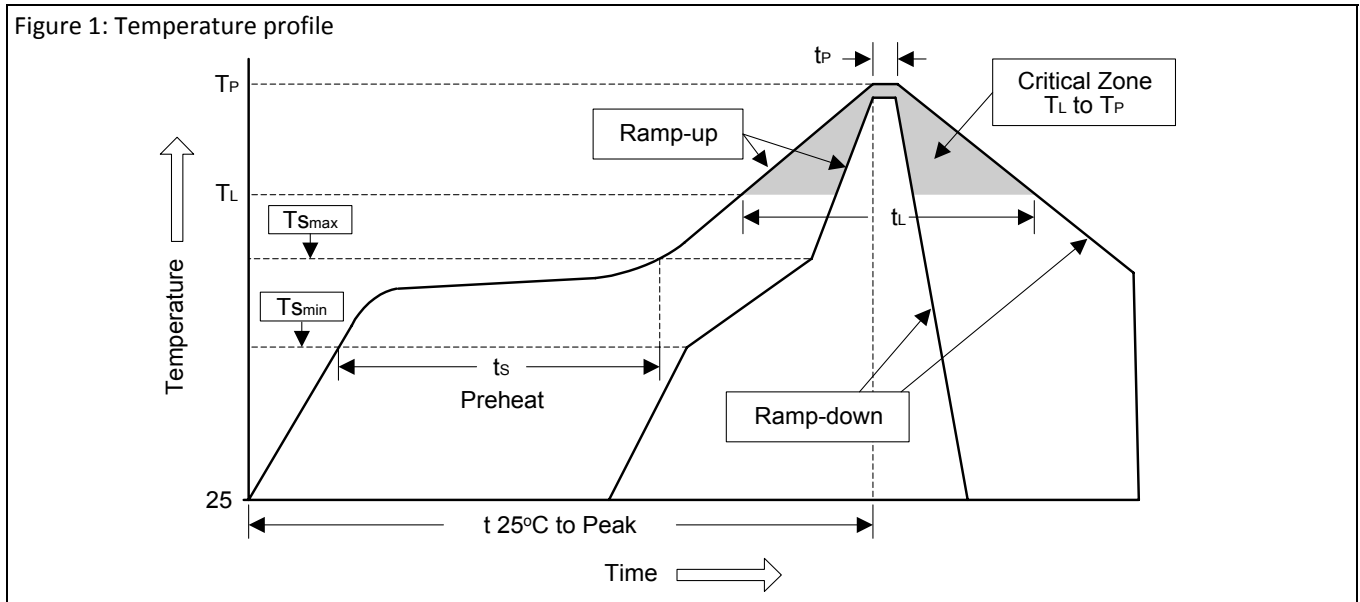

Profile Feature	Sn-Pb Eutectic Assembly	Pb-Free Assembly
Average ramp-up rate (T_L to T_P)	<3°C/sec	<3°C/sec
Preheat		
- Temperature Min (T_{Smin})	100°C	150°C
- Temperature Max (T_{Smax})	150°C	200°C
- Time (min to max) (t_s)	60~120 sec	60~180 sec
T_{Smax} to T_L		
- Ramp-up Rate	<3°C/sec	<3°C/sec
Time maintained above:		
- Temperature (T_L)	183°C	217°C
- Time (t_L)	60~150 sec	60~150 sec
Peak Temperature (T_P)	240°C +0/-5°C	260°C +0/-5°C
Time within 5°C of actual Peak Temperature (t_p)	10~30 sec	20~40 sec
Ramp-down Rate	<6°C/sec	<6°C/sec
Time 25°C to Peak Temperature	<6 minutes	<8 minutes

3. Flow (wave) soldering (solder dipping)

Products	Peak temperature	Dipping time
Pb devices.	245°C ±5°C	5sec ±1sec
Pb-Free devices.	260°C +0/-5°C	5sec ±1sec

Important Notice:

© Orister Corporation

Orister cannot assume responsibility for use of any circuitry other than circuitry entirely embodied in an Orister product. No circuit patent licenses, copyrights, mask work rights, or other intellectual property rights are implied.

Orister reserves the right to make changes to their products or specifications or to discontinue any product or service without notice. Except as provided in Orister's terms and conditions of sale, Orister assumes no liability whatsoever, and Orister disclaims any express or implied warranty relating to the sale and/or use of Orister products including liability or warranties relating to fitness for a particular purpose, merchantability, or infringement of any patent, copyright or other intellectual property right. In order to minimize risks associated with the customer's applications, adequate design and operating safeguards must be provided by the customer to minimize inherent or procedural hazards. Testing and other quality control techniques are utilized to the extent Orister deems necessary to support this warranty. Specific testing of all parameters of each device is not necessarily performed.

Orister and the Orister logo are trademarks of Orister Corporation. All other brand and product names appearing in this document are registered trademarks or trademarks of their respective holders.