

CCD multichannel detector heads



C7040

C7041

Designed for back-thinned CCD area image sensor

The C7040 and C7041 are high sensitivity multichannel detector heads for use with back-thinned CCD area image sensors (S7030/S7031 series, S11500-1007) that offer high UV sensitivity and quantum efficiency. The C7040 is designed for the non-cooled type (S7030 series, S11500-1007), while the C7041 for the one-stage TE-cooled type (S7031 series) for detection at even lower light levels. Both the C7040 and C7041 incorporate a low-noise driver/amplifier circuit that provides reliable operation from simple external signals. The C7041 also includes a highly stable temperature controller that cools the sensor to a preset temperature level ($T_s = -10\text{ }^\circ\text{C}$) as soon as the power is turned on. If the cooler fails and causes internal circuitry to overheat, the built-in protection circuit automatically turns off the power to the thermoelectric cooler. Despite its compact size, the housing configuration is designed for good heat dissipation, and threaded mounting holes on the front panel allow connections to other devices such as monochrometers. The table (P.2) shows back-thinned CCD image sensors for the C7040 and C7041. The C7040 and C7041 do not come with a CCD image sensor, so select the desired sensor and order it separately.

Controller for multichannel detector head C7557-01 is also available. The software supplied with the C7557-01 allows easy control of the multichannel detector head and data acquisition.

Features

- **Designed for back-thinned CCD area image sensor*1**
C7040: for non-cooled type (S7030 series, S11500-1007)
C7041: for TE-cooled type (S7031 series)
- **Line binning operation*2/area scanning operation**
- **Driver/amplifier circuit for low noise CCD operation**
- **Highly stable temperature controller (C7041)**
Cooling temperature: $-10\text{ }^\circ\text{C} \pm 0.05\text{ }^\circ\text{C}$
- **Simple signal input operation**
- **Compact configuration**

Applications

- **Fluorescence spectroscopy**
- **Raman spectroscopy**
- **Other low-light-level detection**

*1: In normal CCD image sensors that receive light from the front surface, the active area is covered with electrodes for charge transfer. These electrodes cut off UV radiation incident on the image sensor and also reduce the quantum efficiency. In contrast, back-thinned CCD image sensors have a unique structure in which the back of the active area is finely ground to allow light to enter from the back surface. This structure ensures high UV sensitivity and quantum efficiency because incident light need not pass through the electrodes.

*2: The CCD area image sensor can be operated like a linear image sensor having a large active area by transferring all the pixel signals in the vertical direction to the horizontal register (this is referred to as line binning).

Selection guide

The table below shows CCD area image sensors applicable for the C7040 and C7041. Since the C7040 and C7041 do not include a CCD area image sensor, so select the desired sensor and order it separately.

Type No.	CCD area image sensor			
	Type No.	Number of pixels	Number of active pixels	Active area [mm (H) × mm (V)]
C7040	S7030-0906	532 × 64	512 × 58	12.288 × 1.392
	S7030-0907	532 × 128	512 × 122	12.288 × 2.928
	S7030-0908	532 × 256	512 × 250	12.288 × 6.000
	S7030-1006	1044 × 64	1024 × 58	24.576 × 1.392
	S7030-1007	1044 × 128	1024 × 122	24.576 × 2.928
	S7030-1008	1044 × 256	1024 × 250	24.576 × 6.000
	S11500-1007	1044 × 128	1024 × 122	24.576 × 2.928
C7041	S7031-0906S	532 × 64	512 × 58	12.288 × 1.392
	S7031-0907S	532 × 128	512 × 122	12.288 × 2.928
	S7031-0908S	532 × 256	512 × 250	12.288 × 6.000
	S7031-1006S	1044 × 64	1024 × 58	24.576 × 1.392
	S7031-1007S	1044 × 128	1024 × 122	24.576 × 2.928
	S7031-1008S	1044 × 256	1024 × 250	24.576 × 6.000

Note: CCD multichannel detector head C7042 for two-stage TE-cooled CCD area image sensor S7032/-1006/-1007/-1008 is also available.

Absolute maximum ratings

Parameter	Symbol	Min.	Typ.	Max.	Unit
Supply voltage (for digital circuitry)	VD1	-0.5	-	+7	V
Supply voltage (for analog circuitry)	VA1+	-	-	+18	
	VA1-	-	-	-18	
	VA2	-	-	+30	
Supply voltage	VD2	-	-	+7	
	Vp	-	-	+7	
	VF	-	-	+14	
Digital input voltage	-	-	-	VD (1, 2)	
Operating temperature	C7040	0	-	+50	°C
	C7041	+10	-	+35*3	
Storage temperature	C7040	-20	-	+70	
	C7041	0	-	+50	

*3: The maximum value may be lower, depending on the drive frequency and the number of sensor pixels.

Electrical characteristics

(Ta=25 °C, VD1=+5 V, VA1+=+15 V, VA1=-15 V, VA2=+24 V, VD2=+5 V, Vp=+5 V, VF=+12 V, unless otherwise noted)

Parameter	Symbol	Min.	Typ.	Max.	Unit	
Digital input	High level	VIH	+2.0	-	VD (1, 2)	
	Low level	VIL	-0.5	-	+0.8	
CLK frequency	fCLK	-	-	1	MHz	
Data video readout frequency	fV	-	-	fCLK/4	Hz	
Start pulse width	tst	1/fCLK	-	-	s	
Digital output	High level (Io=-6 mA)	VIH	+2.0	-	V	
	Low level (Io=+6 mA)	VIL	-	-	+0.8	
Power supply operating conditions						
Voltage	Digital circuitry	VD1	+4.75	+5.0	+5.25	V
	Analog circuitry	VA1+	+14.5	+15.0	+15.5	V
		VA1-	-14.5	-15.0	-15.5	V
		VA2	+23.5	+24.0	+24.5	V
	Other	VD2	+4.75	+5.0	+5.25	V
		Vp	+4.75	+5.0	+5.25	V
VF		+11.75	+12.0	+12.25	V	
Current	VD1 (+5 VDC)	-	-	-	+200	mA
	VA1+ (+15 VDC)	-	-	-	+100	mA
	VA1- (-15 VDC)	-	-	-	-100	mA
	VA2 (+24 VDC)	-	-	-	+30	mA
	VD2 (+5 VDC)*4	-	-	-	+30	mA
	Vp (+5 DC)*4	-	-	-	+2.5	A
	VF (+12 VDC)*4	-	-	+100	-	mA

*4: C7041

Electrical and optical characteristics

(Ta=25 °C, Ts=-10 °C, VD1=+5 V, VA1+=+15 V, VA1=-15 V, VA2=+24 V, VD2=+5 V, Vp=+5 V, Vf=+12 V)

Parameter	Symbol	Min.	Typ.	Max.	Unit
Spectral response range	λ	-	200 to 1100	-	nm
Full well capacity	Vertical	240	320	-	ke ⁻
	Horizontal	800	1000	-	
Conversion gain*5	Sv	-	15	-	$\mu\text{V}/e^-$
Dark current*6	C7040 (Ta=25 °C)	-	100	1000	e ⁻ /pixel/s
	C7041 (Ta=-10 °C)	-	3	30	
Readout noise	Nr	-	20	-	e ⁻ rms
Dynamic range	DR	-	33333	-	-
Photo response non-uniformity*7	PRNU	-	± 3	± 10	%

*5: Including the circuit gain

*6: At MPP mode. Vertical register value. The actual value equals the sum of the vertical direction because of the binning operation.

*7: Measured at 50 % of the full well capacity

Specifications for temperature controller (C7041)

(Ta=25 °C, VD1=+5 V, VA1+=+15 V, VA1=-15 V, VA2=+24 V, VD2=+5 V, Vp=+5 V, Vf=+12 V)

Parameter*8	Symbol	Min.	Typ.	Max.	Unit
Cooling temperature	Ts	-11	-10	-9	°C
Temperature control range	ΔT_s	-0.05	-	+0.05	°C
Power dissipation of TE-cooler element	Pp	-	-	7	W
Cool down time to reset temperature	to	-	-	5	min
Setting temperature for overheat protection*9	To	-	+45	-	°C

*8: Other functions include error display, automatic power off, and detection of electrical opens and shorts by the thermosensor.

*9: Temperature on the rear of the case (where the fan is installed)

Spectral response (without window)

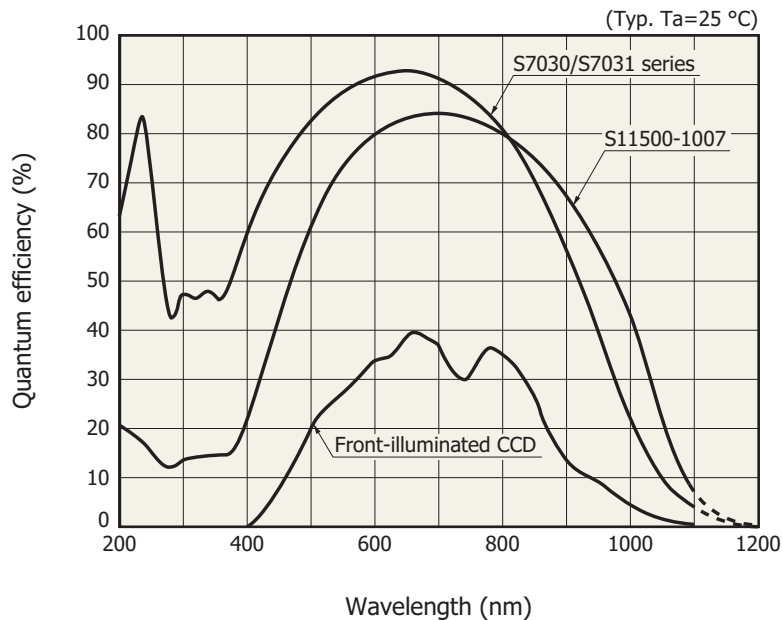

KMPD80038EB

Dark current vs. temperature

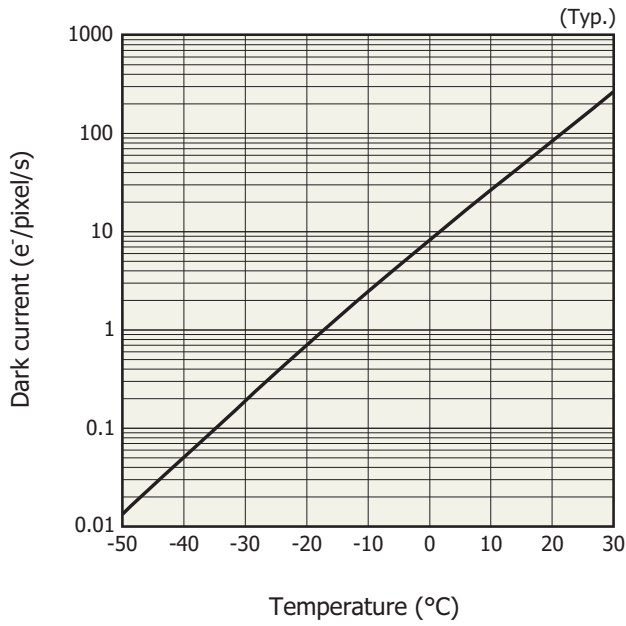

KMPD80256EA

Device structure (S7030/S7031 series)

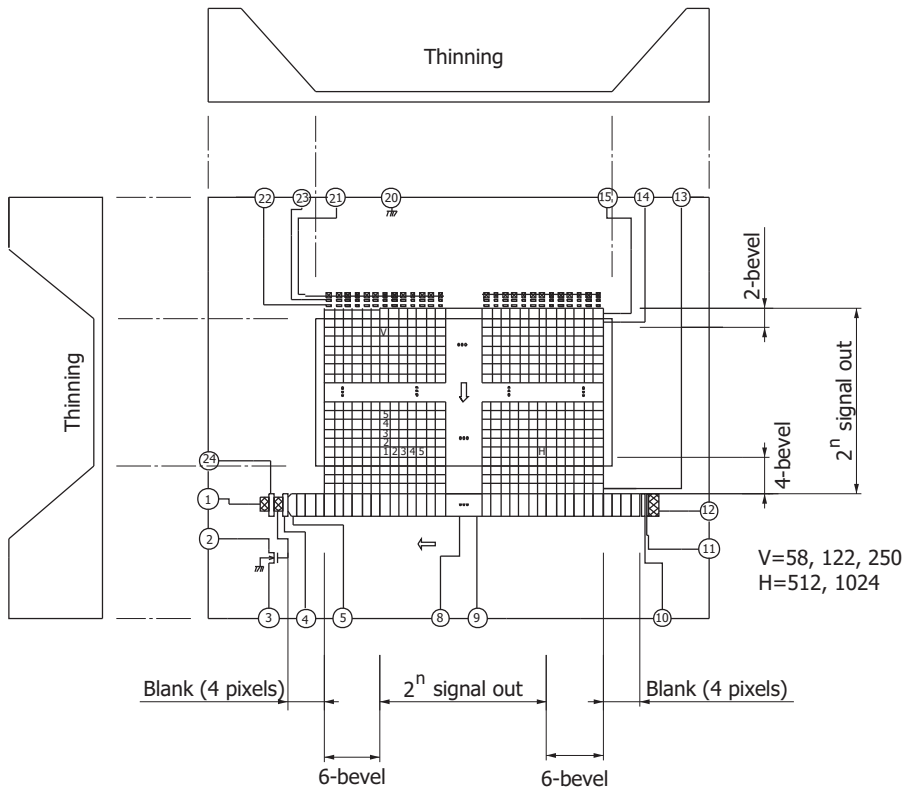

KMPDC0016EB

Block diagram (C7041)

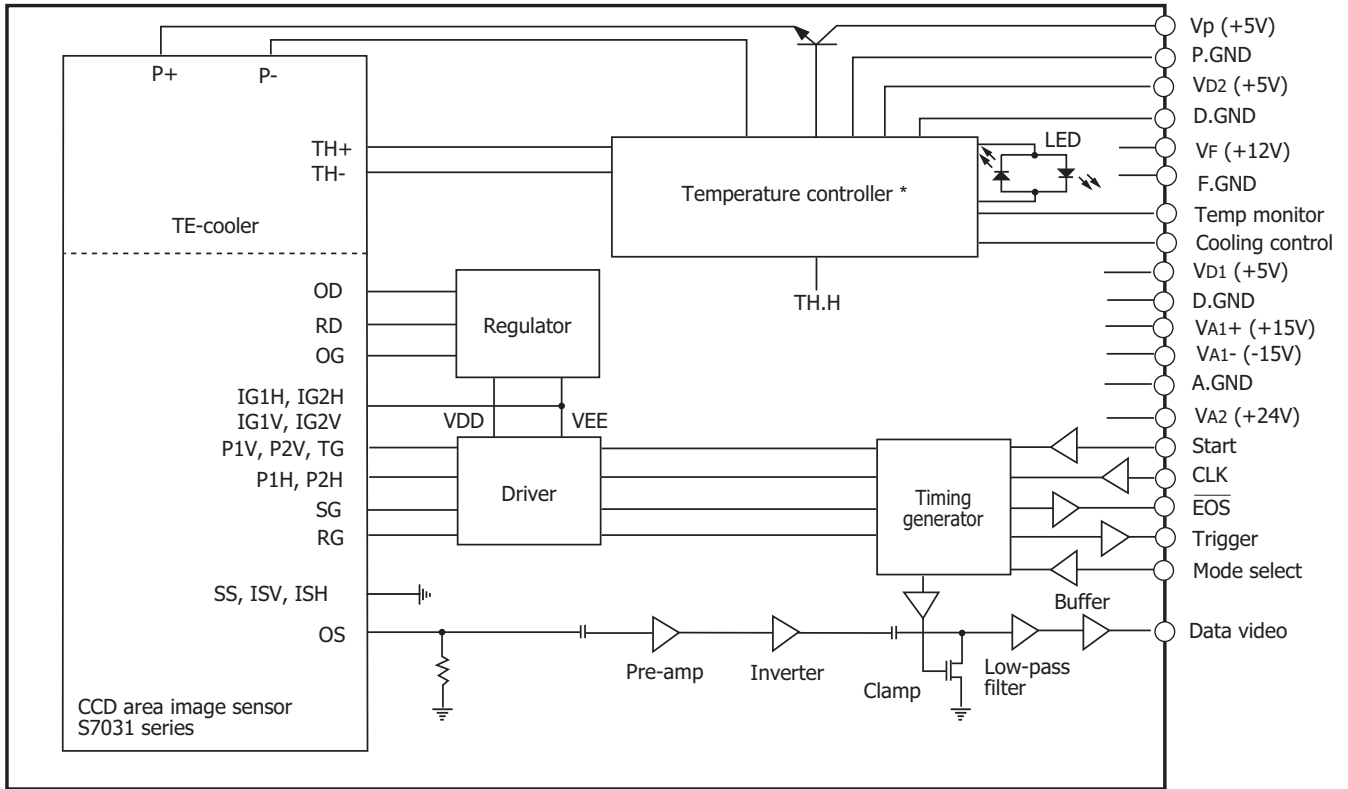

* The C7040 does not include the temperature controller and TE-cooler.

KACCC0078EB

Timing chart (line binning operation)

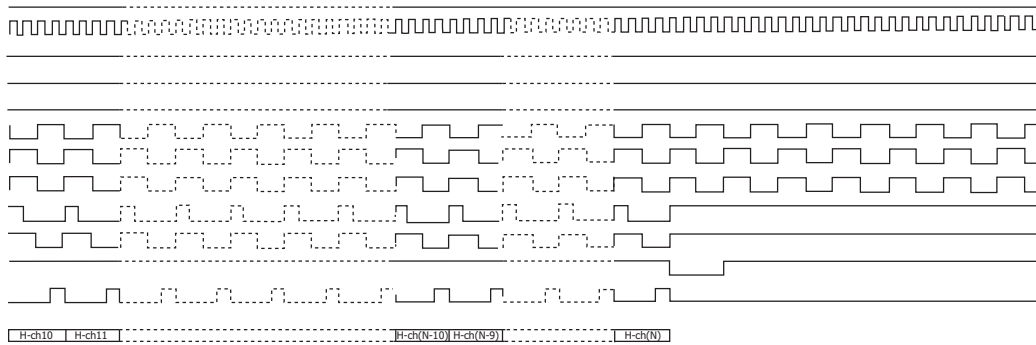
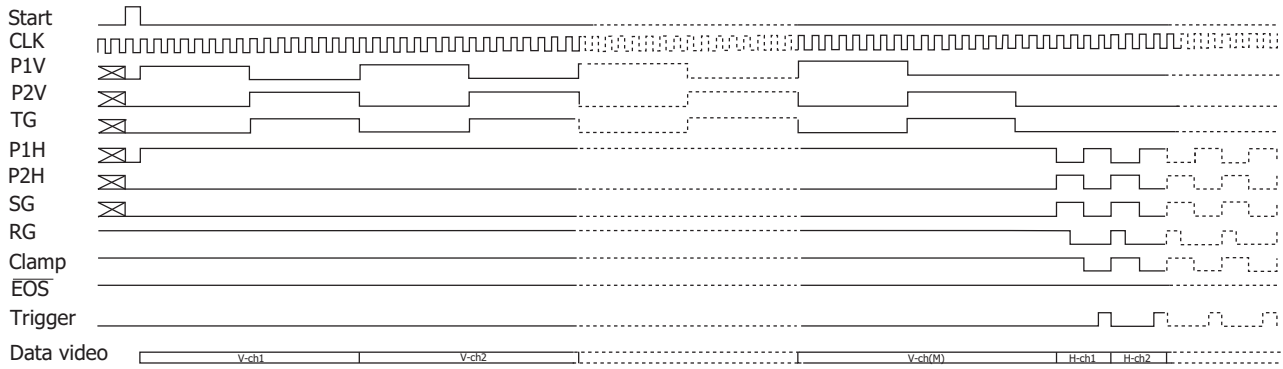

M=64, 128, 256 N=532, 1044
 V-ch1--V-ch2, V-ch (M-3)--V-ch (M): Isolation pixels
 H-ch1--H-ch4, H-ch (N-3)--H-ch (N): Blank pixels
 H-ch5--H-ch10, H-ch (N-9)--H-ch (N-4): Isolation pixels

KACCC0079EC

Pin connections of "SIGNAL I/O" connector

15-pin D-sub connector

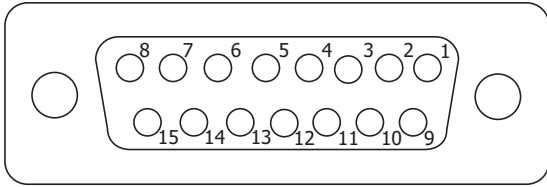

KACCC0069EA

Pin No.	Terminal name	Description
1	Mode select	Digital input signal used to select between the line binning operation and area scanning operation. HCMOS compatible. High level or left open: line binning operation Low level: area scanning operation
2	Data video	Analog video output. Positive polarity.
3	VA1+ (+15 V)	Analog power supply
4	VA1- (-15 V)	Analog power supply
5	VD1 (+5 V)	Digital power supply
6	Start	Digital input signal for initializing the circuit. HCMOS compatible. Positive logic. The interval of the Start pulses determines the integration time of the CCD image sensor.
7	CLK	Digital input signal for operating the circuit. HCMOS compatible. Rising edge operation.
8	$\overline{E}OS$	Digital output signal for indicating end-of-scan of the image sensor. HCMOS compatible. Negative logic.
9	A.GND	Analog ground
10	A.GND	Analog ground
11	VA2 (+24 V)	Analog power supply
12	D.GND	Digital ground
13	D.GND	Digital ground
14	D.GND	Digital ground
15	Trigger	Digital output signal for A/D conversion. HCMOS compatible. Positive logic.

Pin connections of "TE CONTROL I/O" connector (C7041)

9-pin D-sub connector

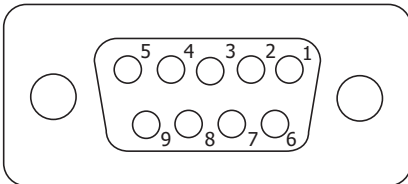

KACCC0075EA

Pin No.	Terminal name	Description
1	VD2 (+5 V)	Digital power supply
2	Temp monitor	Analog output signal of the temperature of the CCD image sensor
3	Cooling control	Digital input signal for starting to cool down. HCMOS compatible. High level or left open: cooling Low level: stand-by
4	Vp (+5 V)	Power supply for the thermoelectric cooler in the CCD image sensor (Please use AWG 18 wire)
5	VF (+12 V)	Power supply for cooling fan
6	D.GND	Ground
7	D.GND	Ground
8	P.GND	Power supply return of the thermoelectric cooler mounted in the CCD image sensor (Please use AWG 18 wire)
9	F.GND	Power supply return for cooling fan

Available for using same power supply (+5 V) for "+Vd2" and "+Vp"

Caution: Do not connect "Vd2" and "Vp" together on the backside of the 9-pin D-sub connector.

These may be connected (shorted) at the power supply end, not 9-pin D-sub connector.

Dimensional outlines (unit: mm)

C7040

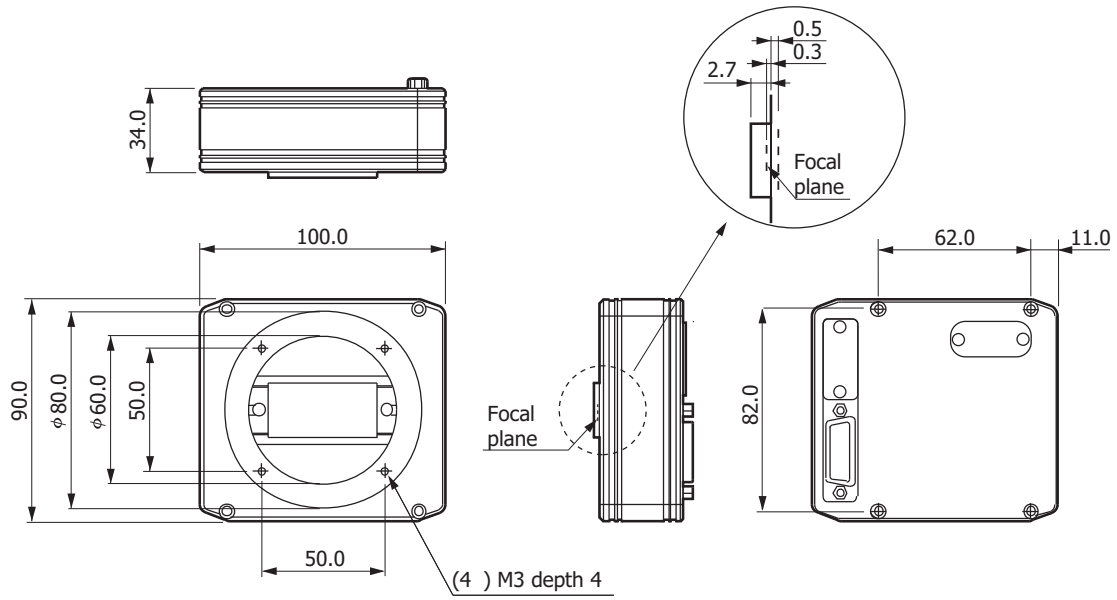

KACCA0062EC

C7041

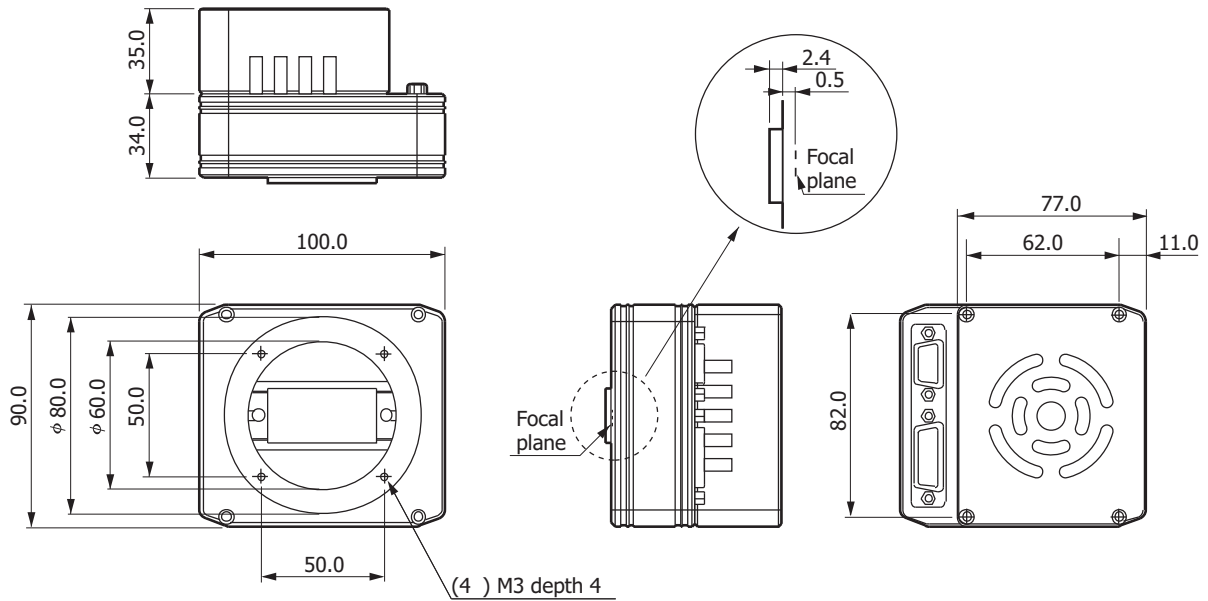

KACCA0063EC

Pin connections

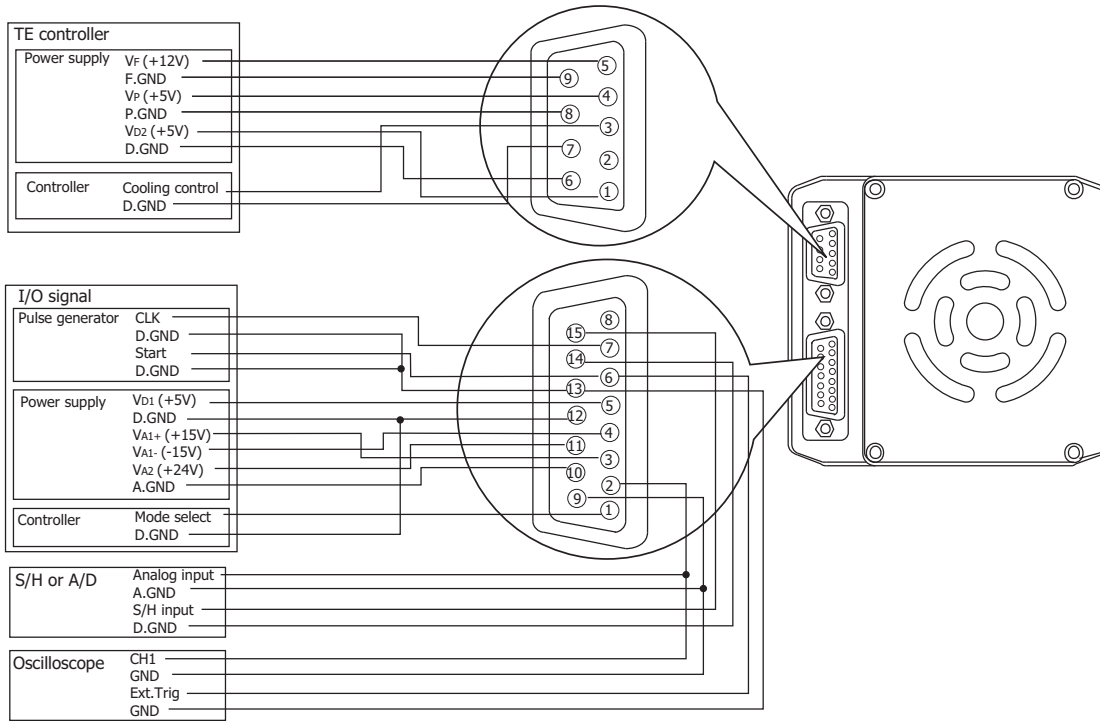

KACCC0076EC

Multichannel detector head controller C7557-01

When connected to a HAMAMATSU multichannel detector head and a personal computer, the C7557-01 allows easy control of the detector head and data acquisition by using dedicated software that comes with the unit.

Suitable multichannel detector head

C7020/-02, C7021/-02, C7025/-02,
 C7040, C7041, C7043, C7044, C7180,
 C7181, C8061-01, C8062-01, C10150, C10151,
 C5964 series, C8892



Accessories

- Spare fuse (2.5 A)*10
- AC cable
- 2 to 3 conversion adapter
- USB cable
- Detector head connection cables (for "SIGNAL I/O" and "TE CONTROL I/O" terminal of multichannel detector head)
- CD-R (MCD USB driver, software, operation manual)
- MOS adapter*11

*10: Contained in the holder just above the AC cable connector on the C7557-01 rear panel.

*11: When operating the NMOS multichannel detector head, always be sure to attach the MOS adapter (supplied) to the C7557-01 main unit. If the the NMOS multichannel detector head is connected and the power is turned on without attaching the adapter, the power supply in the C7557-01 main unit may be damaged.

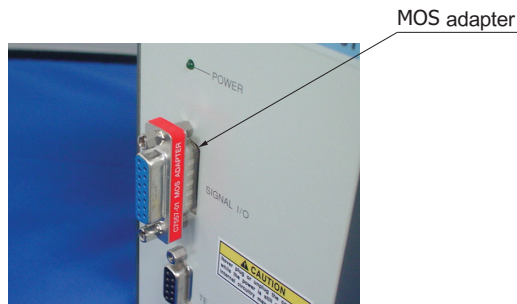

MOS adapter mounting example

Connection example

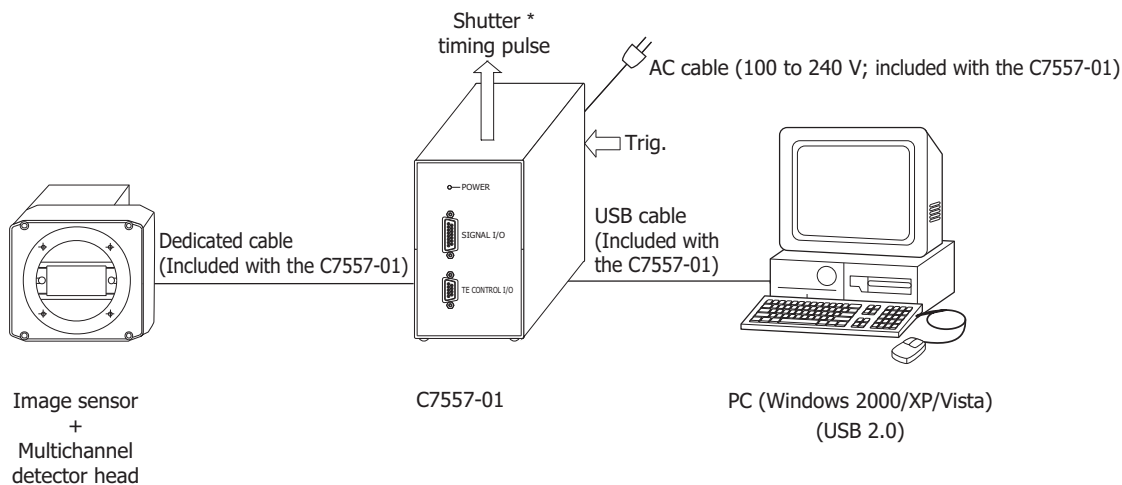

KACCC0402EA

Information furnished by HAMAMATSU is believed to be reliable. However, no responsibility is assumed for possible inaccuracies or omissions.

Specifications are subject to change without notice. No patent rights are granted to any of the circuits described herein.

Type numbers of products listed in the specification sheets or supplied as samples may have a suffix "(X)" which means tentative specifications or a suffix "(Z)" which means developmental specifications. ©2010 Hamamatsu Photonics K.K.

HAMAMATSU

www.hamamatsu.com

HAMAMATSU PHOTONICS K.K., Solid State Division

1126-1 Ichino-cho, Higashi-ku, Hamamatsu City, 435-8558 Japan, Telephone: (81) 53-434-3311, Fax: (81) 53-434-5184

U.S.A.: Hamamatsu Corporation: 360 Foothill Road, P.O.Box 6910, Bridgewater, N.J. 08807-0910, U.S.A., Telephone: (1) 908-231-0960, Fax: (1) 908-231-1218

Germany: Hamamatsu Photonics Deutschland GmbH: Arzbergerstr. 10, D-82211 Herrsching am Ammersee, Germany, Telephone: (49) 8152-375-0, Fax: (49) 8152-265-8

France: Hamamatsu Photonics France S.A.R.L.: 19, Rue du Saule Trapu, Parc du Moulin de Massy, 91882 Massy Cedex, France, Telephone: 33-(1) 69 53 71 00, Fax: 33-(1) 69 53 71 10

United Kingdom: Hamamatsu Photonics UK Limited: 2 Howard Court, 10 Tewin Road, Welwyn Garden City, Hertfordshire AL7 1BW, United Kingdom, Telephone: (44) 1707-294888, Fax: (44) 1707-325777

North Europe: Hamamatsu Photonics Norden AB: Smidesvägen 12, SE-171 41 Solna, Sweden, Telephone: (46) 8-509-031-00, Fax: (46) 8-509-031-01

Italy: Hamamatsu Photonics Italia S.R.L.: Strada della Moia, 1 int. 6, 20020 Arese, (Milano), Italy, Telephone: (39) 02-935-81-733, Fax: (39) 02-935-81-741