

# Keysight Technologies

## 5G Channel Sounding, Reference Solution

Solution Brochure

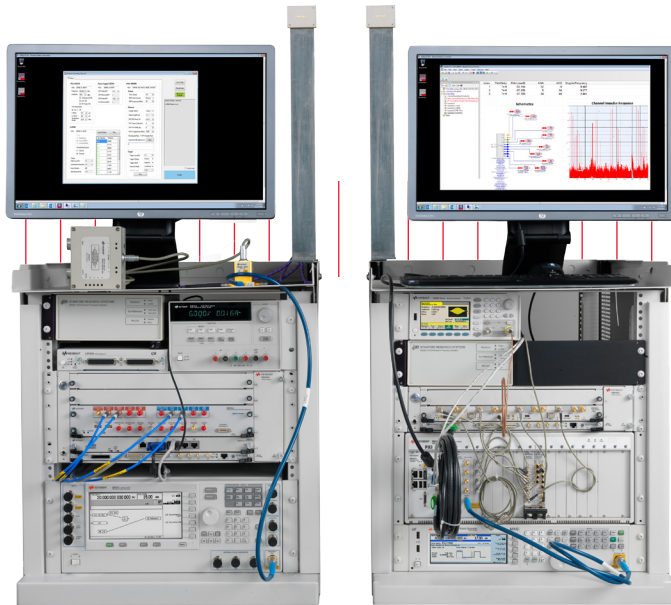

# Accelerate 5G Channel Sounding Research with mmWave, Ultra-broadband and MIMO Solution

## Introduction

Current LTE/LTE-Advanced standards lack the performance needed to keep up with market demand for higher data throughput, greater cell capacity and more reliability. Thus, new 5G cellular standards are being developed to achieve the desired performance goals and to co-exist with 4G technologies. New wireless channels are being considered at frequencies below 6 GHz such as 3.6 and 5 GHz. However, there is very limited spectrum available below 6 GHz so mmWave frequencies that can incorporate wide-bandwidth transmissions are being investigated for next generation cellular systems. New air interface standards being investigated above 6 GHz include 15, 28, 32, 38, 45, 72 GHz and higher.

In order to define new channel models at mmWave frequencies, research and design engineers need to understand how the radio signal will propagate at the given frequencies. Key obstacles at these higher frequencies include path loss, Doppler Effect, environmental effects such as oxygen absorption and rain, and channel sounding techniques are used to analyze the impact of these obstacles on signal transmissions. These techniques use mathematical models to extract the characteristics of the wireless channel to determine the channel performance at a given frequency. The Keysight Technologies, Inc. Channel Sounding Reference Solution combines Keysight's metrology grade, off-the-shelf hardware plus software for 5G channel sounding measurements and optional services enabling in-depth analysis of potential 5G channels.

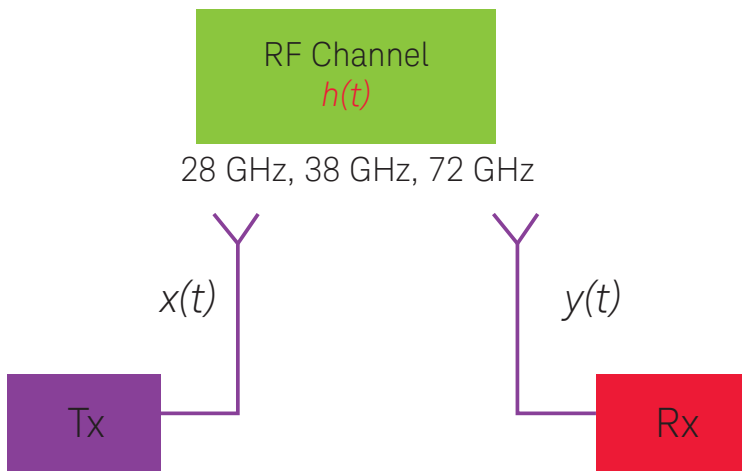

### Key Data:

- Power Delay Profile
- AoA, AoD, AS (angular spread)
- Doppler Shift

## 5G Channel Sounding Test Challenges

Evaluation of time-varying, multi-path frequency bands requires highly complex, multi-channel instrumentation that includes precise timing and synchronization and advanced software to capture and characterize a potential channel. Key measurements include:

- Frequency response by amplitude and unwrapped phase and group delay
- Absolute path loss and power delay profile (PDP)
- Angle of Arrival (AoA)
- Angle of Departure (AoD)

Key test challenges faced by design and research engineers include:

- Ability to generate and analyze wideband, MIMO signals at mmWave frequencies
- Ability to do calibrations for wideband transmitter and receiver test that include vector pre-corrections, IQ frequency response and IQ imbalance, channel to channel skew
- Significant time to collect and manage huge amounts of data
- Tx/Rx timing and synchronization to get accurate

### Technical Challenges

- Signal generation and capture
  - mmWave frequency band
  - Ultra-broad bandwidth
  - MIMO
- Data streaming & storage
- Channel parameter estimation processing
- Calibration and synchronization

## 5G Channel Sounding Reference Solution

To help address these test challenges, the 5G Channel Sounding Reference Solution combines hardware, software and measurement expertise providing the essential components of a 5G channel sounding test platform. This enables engineers and researchers to use, enhance and modify the test platform as required to meet specific test needs such as scaling channel count, transmitting and measuring in the mmWave frequencies, wide transmission and analysis bandwidth, and capture of data for post processing. This Reference Solution uses wideband signal correlation with switching at the transmitter and parallel acquisition at the receiver, as shown in Figure 1, below.

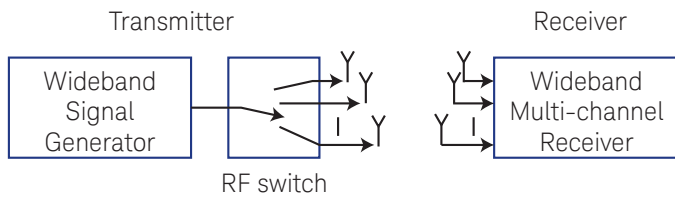

Figure 1. Illustration of wideband signal correlation and parallel acquisition at the receiver.

With parallel acquisition at the receiver, the multiple signals are captured and sent to the digitizer FPGAs for processing. The Reference Solution software includes an option to perform real-time correlation and processing of the Channel Impulse Response (CIR) data in the M9703A digitizer FPGA, speeding up the data collection process and drastically reducing the amount of data that needs to be collected. Post processing channel parameter estimations can also be made using custom algorithms in SystemVue.

Calibration and synchronization are critical to achieving accurate measurements such as absolute delay, AoA, AoD. In addition to the system-wide calibrations, the phase coherent measurement channels include channel to channel corrections for phase and magnitude skew. The Reference Solution enables precise synchronization between the Tx and Rx by using the high precision 10 MHz LO (provided by Rubidium clocks) and triggering.

The 5G channel sounding Reference Solution supports applications up to a 44 GHz frequency range with 2 GHz stimulus and 1 GHz analysis bandwidth up to 8 channels. Custom solutions to support higher frequency ranges, wider analysis bandwidths and a larger number of channels are also available. If this is required for your application, please contact your Keysight representative.

## Reference Solution Architecture

The following shows a simplified block diagram of the 5G Channel Sounding Reference Solution. This solution is scalable and flexible. It can be scaled to address more channels by adding additional downconverters and digitizers or higher frequencies using Keysight “up/down converters” per channel.

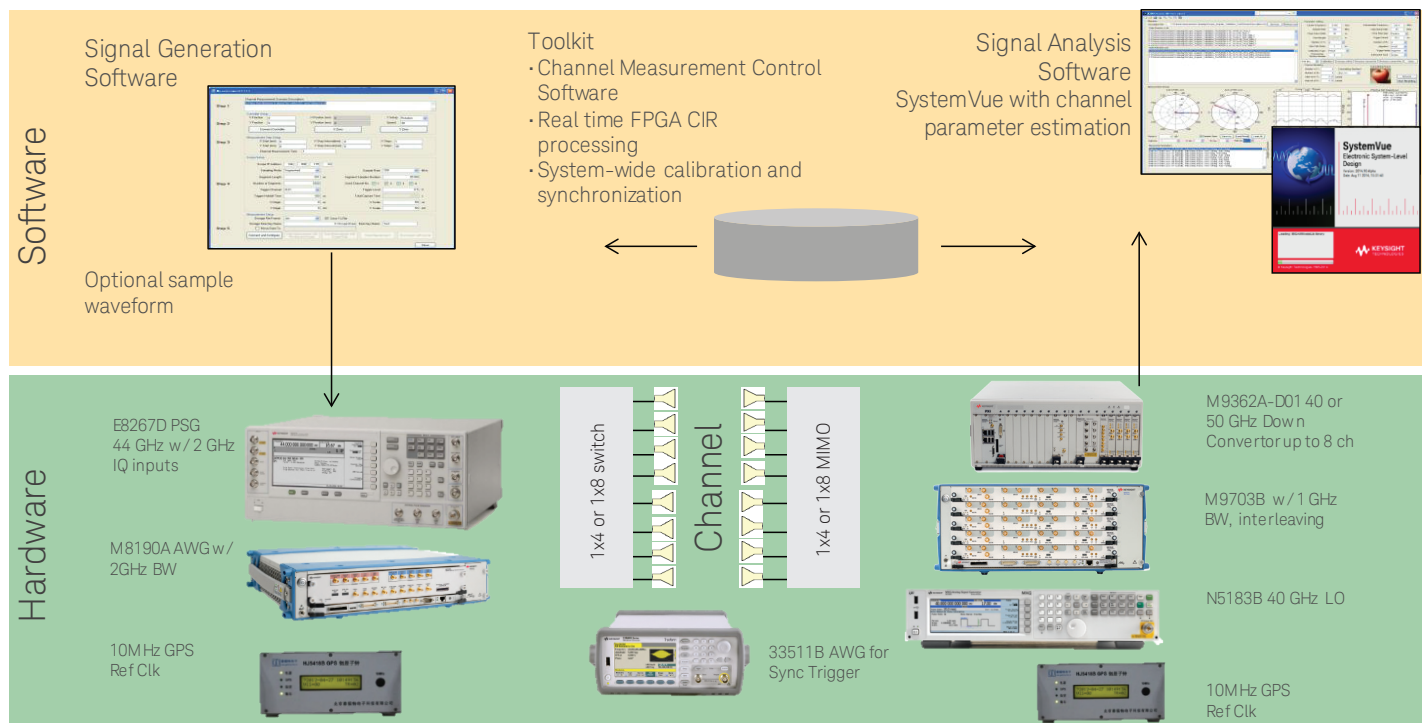

Figure 2. 5G channel sounding Reference Solution architecture.

## Reference Solution Features and Benefits

Features	Benefits
Calibrated and synchronized wideband signal generation and analysis at mmWave frequencies	Confidence in accurate broadband channel sounding measurements for analysis of new 5G channels
Multiple phase-coherent, wideband digitizer channels with optional FPGA for real-time CIR analysis	Speeds data collection with real-time CIR and requires less disk space/memory
World's first 5G exploration library for design and simulation in SystemVue	Flexible and scalable for new 5G tests as standards evolve

### Key Performance Specifications

The Reference Solution provides for:

- Tx/Rx up to 44 GHz with 1 GHz bandwidth that is scalable to higher frequencies with Keysight up/down converters
- 4 or 8 MIMO channels, extendable up to 104 channels
- Capture multiple, phase coherent channels for optional real-time processing of Channel Impulse Response (CIR) in On-board FPGAs
- IO control supports synchronizes Tx and Rx to <1 e-12 accuracy and <1e-12 stability

#### Key Product Specifications

##### M9703A AXIe 12-bit, 3.2 GS/s wideband digitizer

12-bit phase-coherent channels scalable from 8 to 104 channels

1 GHz analysis bandwidth with interleaving mode

Real-time CIR data processing in FPGA

##### M9362A-D01 PXIe microwave downconverter

4 coherent channels per module

26.5, 40, or 50 GHz frequency options

1 GHz analog bandwidth

##### M9352A PXI hybrid amplifier/attenuator

4 channels per module

1 GHz analog bandwidth with 36 dB gain

##### N5183B MXG microwave analog signal generator for uW LO

13, 20, 31.8, or 40 GHz

+20 dBm output power @ 20 GHz, +15 dBm @ 40 GHz

-124 dBc/Hz phase noise at 10 GHz and 10 kHz offset

-116 dBc/Hz phase noise @ 40 GHz

##### E8267D PSG vector signal generator

20, 31.8, 44 GHz extendable to 75, 90 or 110 GHz with mmWave up converters

+23 dBm output power to 20 GHz and +13 dBm @ 40 GHz with differential IQ outputs

External differential I/Q inputs with up to 2 GHz modulation bandwidth

##### M8190A 12 GS/s arbitrary waveform generator

14-bit res up to 8 GS/s or 12-bit res up to 12 GS/s

2 GHz bandwidth when combined with PSG, or up to 8 GHz standalone using doublet mode

Spurious-free-dynamic range (SFDR) up to 90 dBc, typical

2 GSa arbitrary waveform memory per channel with advanced sequencing

## Hardware Configuration

The combination of this test equipment provides Tx and Rx up to 44 GHz with ultra-broadband and MIMO capability

### M9703A/B AXIe 12-bit digitizer/wide-band receiver



[www.keysight.com/find/m9703a](http://www.keysight.com/find/m9703a)

Make 8 high-speed, high resolution baseband measurements with a single AXIe module. Expand channels and capability by combining multiple modules in a single AXIe chassis with option, perform real-time CIR data processing in digitizer FPGA.

### M9362A-D01 PXIe quad downconverter and M9352A PXI hybrid amplifier/attenuator



[www.keysight.com/find/m9362a-d01](http://www.keysight.com/find/m9362a-d01)

[www.keysight.com/find/m9352a](http://www.keysight.com/find/m9352a)

Match each signal output of the antenna array to the input of the digitizer by using the PXI-based, phase-coherent quad downconverter and amplifier modules. Cover a frequency range of up to 40 GHz with different downconverter options.

### N5183B MXG X-Series microwave analog signal generator



[www.keysight.com/find/n5183b](http://www.keysight.com/find/n5183b)

Provide the downconverters with a local oscillator with low phase noise to maintain phase coherency. The high power output of the MXG allows you to use a splitter to feed the LO to multiple downconverters to ensure phase-coherence.

### M8190A 12 GS/s arbitrary waveform generator



[www.keysight.com/find/m8190a](http://www.keysight.com/find/m8190a)

Use the two channel precision AWG to produce the baseband modulated signal. It provides modulation bandwidths up to 2 GHz on a carrier signal up to 44 GHz using the E8267D PSG. The AWG can operate up to 12 GS/s with 12-bit resolution or 8 GSa/s with 14-bits of resolution. These signals drive the wideband I/Q modulation inputs of an E8267D PSG vector signal generator.

### E8267D PSG vector signal generator



[www.keysight.com/find/e8267d](http://www.keysight.com/find/e8267d)

Provides wide-band signal generation to 44 GHz with +13 dBm output power. The PSG includes wideband differential external I/Q inputs for input of modulation bandwidths up to 2 GHz. For a single channel signal generation at mmWave frequencies, upconverters are available from Keysight.

### M9502A, M9505A or M9514A AXIe chassis for digitizers and AWG



[www.keysight.com/find/axie-chassis](http://www.keysight.com/find/axie-chassis)

The AXIe chassis incorporates multiple high speed digitizers or AWGs on the PCI bus with Gen2, x4 links delivering up to 2 GB/s to the system slot. For smaller MIMO systems, the M9502A will support up to 16 digitizer channels (2 modules) configured for 1.6 GS/s or 8 channels 3.2 GS/s using interleaving mode. For larger systems, the M9505A can support up to 40 digitizer channels (5 modules). Very large systems can be built with the M9514A 14-slot AXIe chassis.

### M9018A 18-slot PXIe chassis with M9037A PXIe embedded controller



[www.keysight.com/find/m9018a](http://www.keysight.com/find/m9018a)

[www.keysight.com/find/m9037a](http://www.keysight.com/find/m9037a)

The M9018A PXIe chassis has 17 instrument slots available for the PXI-based downconverters, amplifiers and frequency reference modules. Incorporate the core i7 based M9037A PXIe controller to control both the AXIe digitizer chassis and the PXIe chassis. The M9037A quickly boots with a preloaded operating system, drivers and Keysight IO libraries on a solid state drive. The PXIe chassis delivers the ultimate in flexibility, compatibility, and performance with PCI Gen2 with x8 links and up to 8 GB/s to system slot. The M9018A has sufficient power for 4 quad downconverters plus 4 amplifier modules and has an innovated cooling design that allows for it to fit into 4U of rack space.

## 5G Channel Sounding Software

Channel sounding characterization requires several steps. Software is used for the following:

- To control instruments, make highly synchronized measurements and generate accurate absolute delay results
- To generate a channel sounding signal and auto correlate to get CIR data
- To use mathematical models for post processing of the data and extract channel parameters
- To perform system-wide calibrations to ensure accurate results

### Channel sounding signal

A channel sounding signal is a critical part of the sounding system. Keysight provides several options for generating channel sounding signals using its signal generation tools such as SystemVue, Waveform Creator, or Signal Studio. Keysight's professional services team also creates custom sounding signals.

### CIR and channel parameter extractions

The Reference Solution includes software to capture, correlate and process the CIR data, which can be taken offline for channel parameter extractions. Different algorithms can be used to extract the channel parameters - each with its own benefits and drawbacks. Keysight offers custom channel parameter extractions based on the SAGE algorithm using the SystemVue platform.

### Simulation with new channel models

Once the channel modeling is complete, the SystemVue 5G libraries can be used to provide link-level simulation of new channel models with scaling schemes for MIMO channels, as well. The integrated simulation environment allows users to investigate, implement and verify new designs through hardware in the loop.

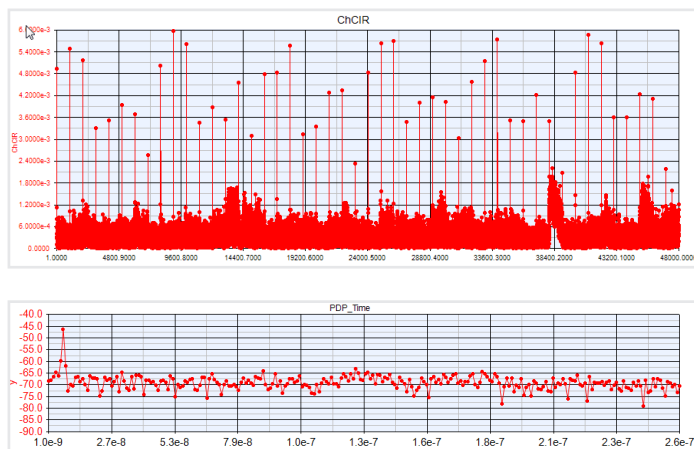

Figure 3. 5G channel sounding CIR results.

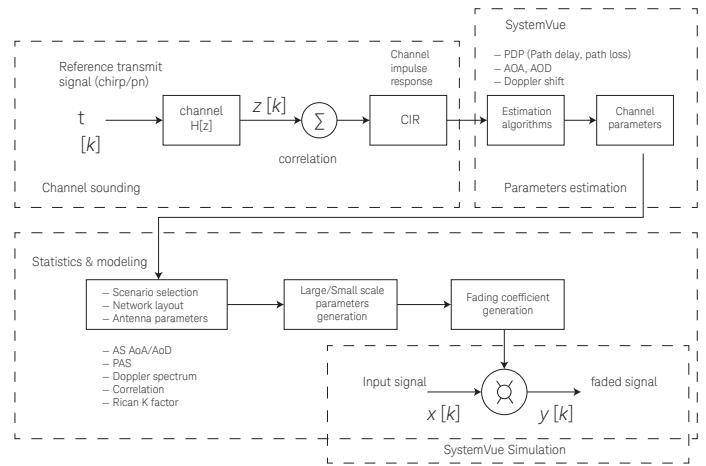

Figure 4. Channel measurement design flow: parameter extraction, modeling and simulation.

## Y1299A Reference Solution Quick Start

Channel sounding characterization requires several steps. This Reference Solution includes the Y1299-006 toolkit that provides configuration and test tools to aid and accelerates the complex channel sounding characterization.

### I/O control software

The I/O control software provided with the Reference Solution enables precise timing and control of the instrumentation. It allows for synchronization of the Tx and Rx subsystems to ensure accurate results for absolute delay measurements. Instrument set up can be saved and recalled to save different measurement states for different frequencies or instrument configurations like SISO or MIMO.

This software controls the Tx switch subsystem and uses the highly synchronized 10 MHz GPS reference clocks and triggers to signal the synchronization of the sounding stimulus signal generation and acquisition. This ensures that the measurements are taken at the correct time.

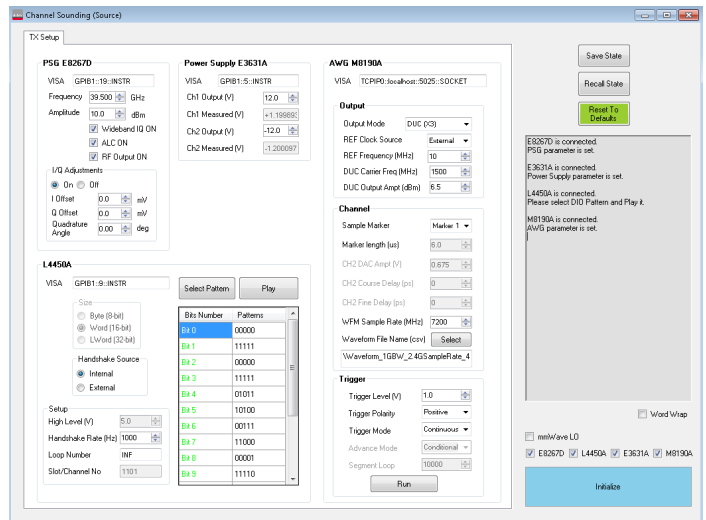

Figure 5. IO control software with instrument set up for synchronization and triggering.

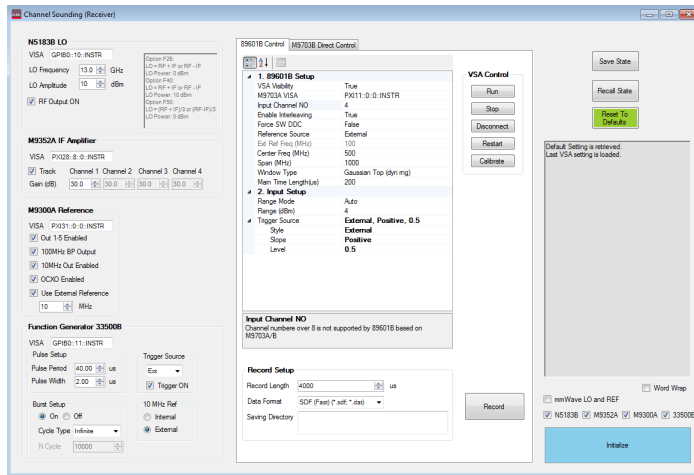

Figure 6. IO control software for RX instrument set up

## System-wide calibration

To achieve precise channel sounding measurement results, calibration is extremely important. The reference solution guides you through a system-wide back-to-back calibration using the 89600 VSA software with specific instructions included for:

- System impulse response
- I/Q imbalance
- Multi-channel magnitude and phase skew
- Power

## Data Storage and Streaming

Channel sounding analysis requires a lot of data collection over long periods of time. When ultra-wide bandwidth and MIMO are included, the data storage requirements are huge. To optimize and reduce data collection, the Reference Solution offers real-time data processing in the M9703A FPGA for real-time correlation and processing to produce the effective CIR data. This data can be stored to memory or sent offline for post processing. Another option is to stream the raw IQ data to a RAID array using the M9703B CB1 or CB2 options.

Contact your Keysight representative for more information.

## Keysight Professional Services

Keysight offers a number of services to complete this solution including:

- Software development services based on the SystemVue platform to create custom sounding signals and channel parameter extractions.
- Productivity services to complete the project delivered by Keysight application experts. This service can be used to provide additional configuration and integration of the complete solution on the customer’s site.
- Extended support and training can also be provided through the professional services teams.

Learn more about:

*Keysight Professional Services, literature number 5989-0099EN.*

## Recommended Reference Solution Configuration

This Reference Solution is flexible and scalable. Buy what you need today and add more channels and capabilities as the 5G measurement requirements evolve.

The following is a summary of a 40 GHz, MIMO solution. See the 5G channel sounding Reference Solution configuration guide, literature number 5991-0990EN for more information on specific configurations.

### Rx subsystem components

Model	Description
<b>M9703B</b>	<b>AXIe 12-bit digitizer</b>
M9703B-SR2	Maximum sampling rate, 1.6 GSa/S per channel
M9703B-M16	memory, 16 GB, 1024 MSa/ch
M9703B-F10	Bandwidth, 1 GHz path enabled
M9703B-INT	Interleaved sampling enabled
M9703B-CB2	IQ streaming, includes DDC
M9703B-CR0	Optional real-time CIR in FPGA, saved to memory, includes DDC
M9703B-DDC	Optional digital downconversion, also included in CR0 and CB2
<b>M9502A</b>	<b>2-slot AXIe chassis</b>
<b>M9352A-H01</b>	<b>PXI amplifier/attenuator</b>
<b>M9362A-D01</b>	<b>PXIe quad downconverter</b>
M9362A-D01-F40	10 MHz – 40 GHz frequency range
<b>M9300A</b>	<b>PXIe frequency reference</b>
<b>M9018A</b>	<b>18-slot PXIe chassis</b>
<b>M9037A</b>	<b>PXIe high-performance embedded controller</b>
M9037A-WE6	Win embedded standard 7 (64-bit)
M9037A-M16	Adds 16 GB memory
<b>N5183B</b>	<b>MXG X-Series microwave analog signal generator</b>
N5183B-1EA	High output power
N5183B-540	Frequency range, 9 kHz to 40 GHz
N5183B-UNY	Low phase noise
<b>33511B</b>	<b>Waveform/function generator</b>

### Software, toolkit

Model	Description
Y1299-006	5G Reference Solution start-up kit
89601B-200	89600 VSA software for Rx calibrations
M9099A- LIC, DFW	Waveform Creator software for Tx calibrations

### Tx subsystem components

Model	Description
<b>M9505A</b>	<b>AXIe 5-slot chassis</b>
<b>M9536A</b>	<b>AXIe embedded controller</b>
M9536A-WE6	Win embedded standard 7 (64-bit)
M9536A-M16	Adds 16 GB memory
<b>M8190A</b>	<b>AXIe AWG</b>
M8190A-002	AWG – 2-Channels
M8190A-02G (x2)	128 MSa to 2 GSa Memory/Ch
M8190A-14B	14-bit resolution
M8190A-805(x4)	Low pass filter
M8190A-811(x4)	Cable assembly
<b>E8267D</b>	<b>PSG vector signal generator</b>
E8267D-016	IQ differential inputs
E8267D-544	Frequency range, 250 kHz to 44 GHz
E8267D-UNX	Ultra low phase noise
<b>E3630A</b>	<b>Power supply</b>
<b>L4450A</b>	<b>64-bit digital IO w/ memory</b>
<b>34950T</b>	<b>Terminal block with screw connectors</b>
<b>85332B</b>	<b>Solid state switch</b>
85332B-201	Switch control unit

### Other hardware and accessories

<b>10 MHz GPS Clocks to provide precise timing and synchronization (Rubidium)</b>
<b>Misc antennas, amplifiers, cables and connectors to complete the system (consult configuration guide for complete list)</b>

### Recommended optional software

Model	Description
W1461BP	SystemVue Comms Architect
W1462BP	SystemVue FPGA Architect
E4729A	Channel Sounding Service used with W1462BP FPGA Architect
W1906BEL	SystemVue 5G Baseband Verification Library

### Recommended optional custom services

Model	Description
PS-S10-100	Remote scheduled productivity assistance
PS-S20-100	Daily instrument and application consulting with customer equipment
PS-X10-100	Application specific technical assistance
E8991A	Daily application consulting / Premium Services with customer System Vue SW



## Hardware Support and Warranty

Keysight provides its standard warranty on all hardware products. The warranty service provides standard coverage for the country where product is sold, including:

- All parts and labor necessary to return to full specified performance
- Recalibration for products supplied originally with a calibration certificate
- Return shipment

Standard hardware warranty includes 3 year warranty on each product with a typical turn-around time of 15 days.

Keysight has optional upgraded warranty services on each product including:

- Extended warranty from 3 years to 5 years
- Express warranty for faster turnaround time (3 or 5 years)

## From Hewlett-Packard through Agilent to Keysight

For more than 75 years, we've been helping you unlock measurement insights. Our unique combination of hardware, software and people can help you reach your next breakthrough. **Unlocking measurement insights since 1939.**

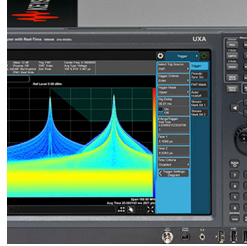
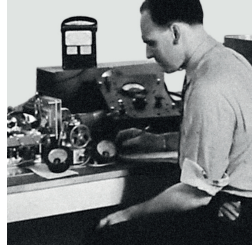

1939

THE FUTURE

For more information on Keysight Technologies' products, applications or services, please contact your local Keysight office. The complete list is available at: [www.keysight.com/find/contactus](http://www.keysight.com/find/contactus)

### Americas

Canada	(877) 894 4414
Brazil	55 11 3351 7010
Mexico	001 800 254 2440
United States	(800) 829 4444

### Asia Pacific

Australia	1 800 629 485
China	800 810 0189
Hong Kong	800 938 693
India	1 800 11 2626
Japan	0120 (421) 345
Korea	080 769 0800
Malaysia	1 800 888 848
Singapore	1 800 375 8100
Taiwan	0800 047 866
Other AP Countries	(65) 6375 8100

### Europe & Middle East

Austria	0800 001122
Belgium	0800 58580
Finland	0800 523252
France	0805 980333
Germany	0800 6270999
Ireland	1800 832700
Israel	1 809 343051
Italy	800 599100
Luxembourg	+32 800 58580
Netherlands	0800 0233200
Russia	8800 5009286
Spain	800 000154
Sweden	0200 882255
Switzerland	0800 805353
	Opt. 1 (DE)
	Opt. 2 (FR)
	Opt. 3 (IT)
United Kingdom	0800 0260637

For other unlisted countries:  
[www.keysight.com/find/contactus](http://www.keysight.com/find/contactus)  
 (BP-02-10-16)



[www.keysight.com/go/quality](http://www.keysight.com/go/quality)  
 Keysight Technologies, Inc.  
 DEKRA Certified ISO 9001:2015  
 Quality Management System

This information is subject to change without notice.  
 © Keysight Technologies, 2015 - 2016  
 Published in USA, April 7, 2016  
 5992-0983EN  
[www.keysight.com](http://www.keysight.com)

**myKeysight**  
[www.keysight.com/find/mykeysight](http://www.keysight.com/find/mykeysight)  
 A personalized view into the information most relevant to you.



### Three-Year Warranty

[www.keysight.com/find/ThreeYearWarranty](http://www.keysight.com/find/ThreeYearWarranty)

Keysight's committed to superior product quality and lower total cost of ownership. Keysight is the only test and measurement company with three-year warranty standard on all instruments, worldwide. And, we provide a one-year warranty on many accessories, calibration devices, systems and custom products.



### Keysight Assurance Plans

[www.keysight.com/find/AssurancePlans](http://www.keysight.com/find/AssurancePlans)

Up to ten years of protection and no budgetary surprises to ensure your instruments are operating to specification, so you can rely on accurate measurements.

**Keysight Infoline**

### Keysight Infoline

[www.keysight.com/find/service](http://www.keysight.com/find/service)

Keysight's insight to best in class information management. Free access to your Keysight equipment company reports and e-library.

### Keysight Channel Partners

[www.keysight.com/find/channelpartners](http://www.keysight.com/find/channelpartners)

Get the best of both worlds: Keysight's measurement expertise and product breadth, combined with channel partner convenience.

[www.keysight.com/find/solution-5GSounding](http://www.keysight.com/find/solution-5GSounding)