

Figure 1

## 1. INTRODUCTION

This instruction sheet covers the use and maintenance of Crimping Die Assemblies 1583015-1, -2, -3, and 1583016-1, which are designed to be used in Hand Crimping Tool Frame Assembly 543344-1 or 58235-1, or in Pneumatic Power Unit 312522-3 equipped with Die Holder Assembly 58449-1. Each die assembly crimps a ferrule onto round shielded cable used with HSSDC2 Connectors.

Reason for revision is given in Section 7, REVISION SUMMARY.



*Dimensions are in millimeters [with inches in brackets]. Figures and illustrations are for reference only and are not drawn to scale.*

## 2. DESCRIPTION

Each die assembly consists of an indenter (stationary die) and an anvil (moving die). When mated, the dies form two crimping sections: the braid and the insulation. The braid section crimps the front part of the ferrule onto the cable shield and the cable outlet of the connector shield assembly, and simultaneously, the insulation section crimps the back part of the ferrule onto the cable insulation. The anvil die is designed with a stop to ensure proper positioning of the ferrule for crimping. See Figure 1.

The ferrule, which is ordered separately from the AMPLIMITE\* connector, is sized according to the insulation diameter of the cable. Each die assembly is marked with the cable insulation diameter range.

## 3. DIE ASSEMBLY INSTALLATION

The die assembly is designed to fit securely into the tool by upper and lower die holder plates; each die is held in by a single screw. To install the die assembly, refer to the instructions packaged with the tool:

408-9315	Hand Crimping Tool Frame Assembly 543344-1
408-9245	Hand Crimping Tool Frame Assembly 58235-1
408-9721	Die Holder Assembly 58449-1
409-5822	Pneumatic Power Unit 312522-3

## 4. CRIMPING PROCEDURE

Assemble the connector. Make sure the ferrule is over the connector shield cable outlet and butted against the shield body. Then, proceed as follows:

1. Place the ferrule on the moving die, with the cable extending out the back side of the die. Make sure that the front part of the ferrule is positioned in the braid section and the back part of the ferrule is positioned in the insulation section. See Figure 2.



*The front edge of the ferrule must be against the stop and the connector body must be clear of the dies.*

2. Actuate tool for crimping according to the instructions packaged with the tool.
3. Remove connector from die assembly and inspect the crimped ferrule to the requirements outlined in the applicable application specification:

114-13028	High Speed Serial Data Connector 2 (HSSDC2)
-----------	---

See Figure 3 for a properly crimped ferrule.

## 5. MAINTENANCE AND INSPECTION PROCEDURE

The die assembly is inspected prior to shipment, however, it is recommended that the die assembly be inspected immediately upon arrival. TE Connectivity recommends that a maintenance and inspection program be performed periodically to ensure continued reliability of the die assembly. The inspection frequency should be based on the amount of use, working conditions, operator training and skill, and established company standards.

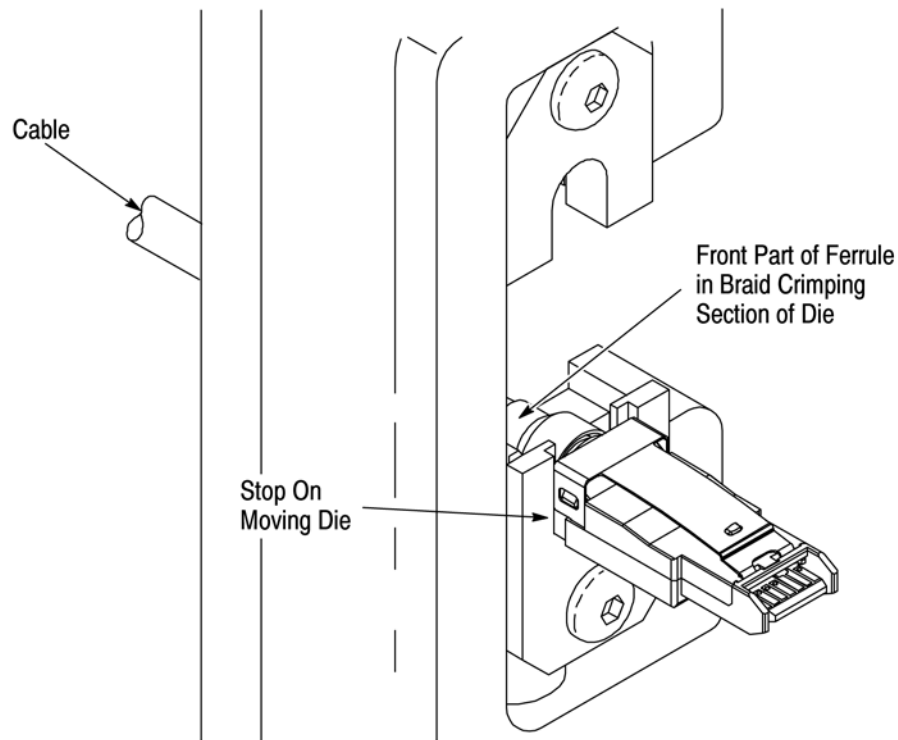

Figure 2

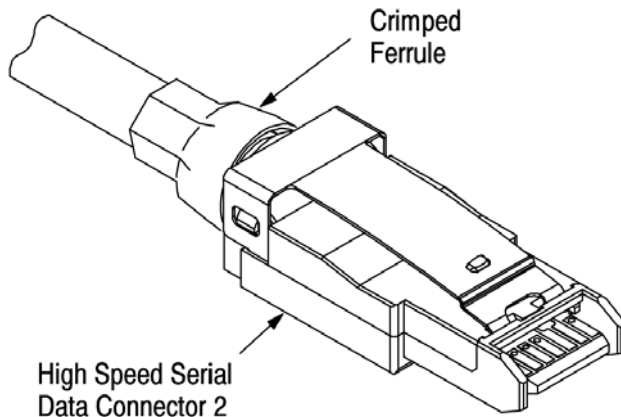

Figure 3

### 5.1. Daily Maintenance

1. Remove accumulated dust, moisture, and other contaminants with a clean, soft brush or lint-free cloth. Do NOT use hard or abrasive objects that could damage the dies.
2. Make sure dies are protected with a THIN coat of any good SAE 20 motor oil. Do NOT oil excessively.

3. When die assembly is not in use, mate and store them in a clean, dry area.

### 5.2. Periodic Inspection

#### A. Visual Inspection

1. Remove all lubrication and accumulated film from the dies by immersing the dies in a suitable commercial degreaser that will not affect paint or plastic material.
2. Make sure that all die retention screws and die components are properly secured.
3. Inspect die assembly for worn, cracked, or broken surfaces. If damage is evident, the dies must be replaced. See Section 6, REPLACEMENT PARTS.

#### B. Gaging the Crimping Section

This inspection requires the use of a plug gage conforming to the dimensions provided in Figure 4. TE does not manufacture or market these gages. To gage the crimping section, remove die assembly from tool and proceed as follows:

1. Remove traces of oil or dirt from the crimping section and plug gage.
2. Mate the dies until the crimping surfaces have bottomed; then hold in this position. DO NOT force the dies beyond initial contact.

**Suggested Plug Gage Design  
For Insulation  
Crimping Section**

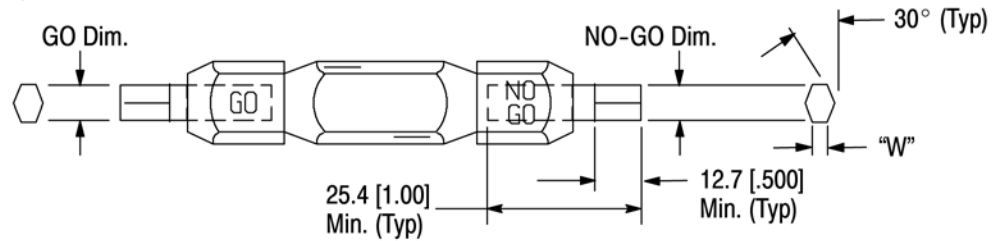

DIE ASSEMBLY PART NUMBER	GAGE ELEMENT DIMENSIONS		
	GO	NO-GO	WIDTH (Max) "W"
1583015-1	4.293-4.300 [.1690-.1693]	4.544-4.547 [1789-.1790]	2.87 [.113]
1583015-2	5.207-5.215 [.2050-.2053]	5.458-5.461 [.2149-.2150]	2.87 [.113]
1583015-3	5.867-5.875 [.2310-.2313]	6.119-6.121 [.2409-.2410]	3.30 [.130]
1583016-1	7.442-7.450 [.2930-.2933]	7.693-7.696 [.3029-.3030]	4.16 [.164]

**Suggested Plug Gage Design  
For Braid Crimping Section**

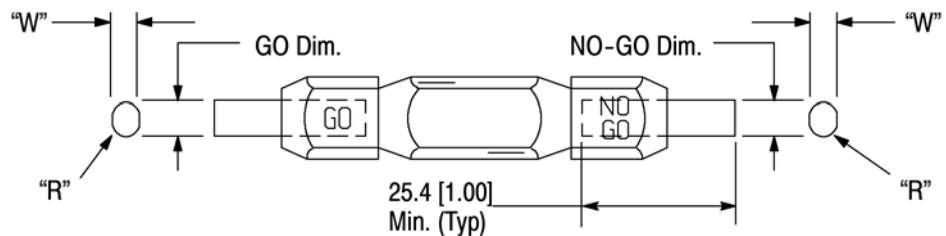

DIE ASSEMBLY PART NUMBER	GAGE ELEMENT DIMENSIONS			
	GO	NO-GO	WIDTH (Max) "W"	RADIUS (Max) "R"
1583015-1, -2, -3	8.572-8.580 [.3375-.3378]	8.773-8.776 [.3454-.3455]	8.51 [.335]	4.27 [.168]
1583016-1	10.223-10.231 [.4025-.4028]	10.424-10.427 [.4104-.4105]	10.16 [.400]	5.08 [.200]

Figure 4

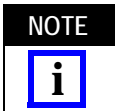

Pivot the stop away from the moving die in order to gage the braid crimping section.

3. Carefully insert GO element into the corresponding crimping section; do not force it. The GO element must pass completely through the crimping section.

4. In the same manner, try to insert the NO-GO element into the same crimping section. The NO-GO element may start entry, but must not pass completely through the crimping section.

If the crimping sections conform to the gage inspection, they are considered dimensionally correct, and should be lubricated with a THIN coat of any good SAE 20 motor oil. If not, the die assembly must be replaced. Refer to Section 6, REPLACEMENT PARTS.

For additional information concerning the use of a plug gage, refer to Instruction Sheet 408-7424.

## 6. REPLACEMENT PARTS

The parts listed in Figure 5 are customer-replaceable. A complete inventory can be stocked and controlled to prevent lost time when replacement of parts is necessary. Parts other than those listed should be replaced by TE to ensure quality and reliability of the die assembly.

CUSTOMER SERVICE (038-035)  
TYCO ELECTRONICS CORPORATION  
PO BOX 3608  
HARRISBURG PA 17105-3608

## 7. REVISION SUMMARY

- New logo

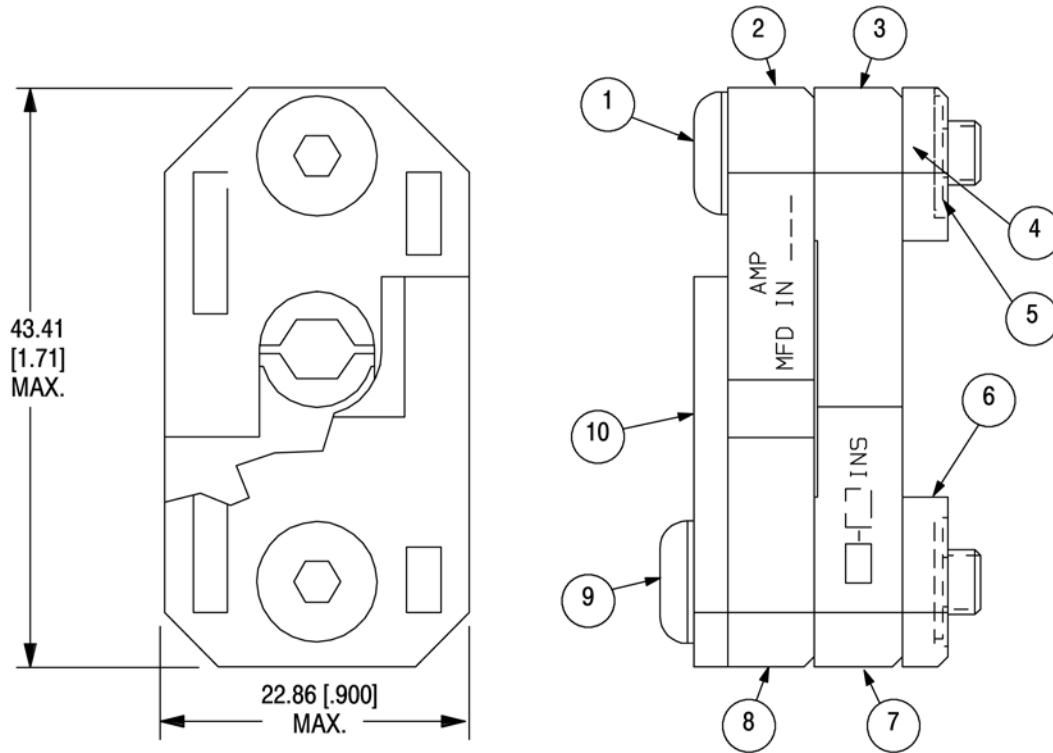

**NOTE:** Crimping Die Assembly 1583015-[ ] shown.

ITEM NO.	DESCRIPTION	CRIMPING DIE ASSEMBLY				QTY PER DIE ASSY
		1583015-1	1583015-2	1583015-3	1583016-1	
1	SCREW, Special	543416-1	543416-1	543416-1	543416-1	1
2	INDENTER, Braid	1583013-1	1583013-1	1583013-1	1583023-1	1
3	INSERT, Insulation, Upper	543410-1	543415-1	543408-1	543399-1	1
4	SPACER, Upper	543411-1	543411-1	543411-1	543411-1	1
5	RING, Retaining, External E-Ring	1-21046-3	1-21046-3	1-21046-3	1-21046-3	2
6	SPACER, Lower	543412-1	543412-1	543412-1	543412-1	1
7	INSERT, Insulation, Lower	543409-1	543414-1	543407-1	543400-1	1
8	ANVIL, Braid	1583012-1	1583012-1	1583012-1	1583022-1	1
9	SCREW, Special	543416-2	543416-2	543416-2	543416-2	1
10	STOP, Ferrule	1583014-1	1583014-1	1583014-1	1583014-1	1

Figure 5