

Rev	AWO #	Description	Date	Appr
-		RELEASED	9/14/10	

APPROVED: _____
 DATE: _____ TITLE: _____

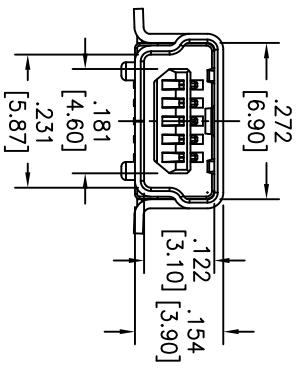
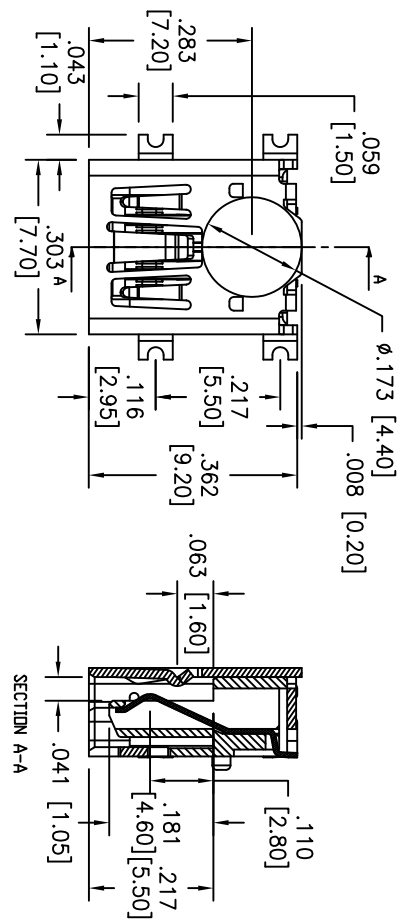
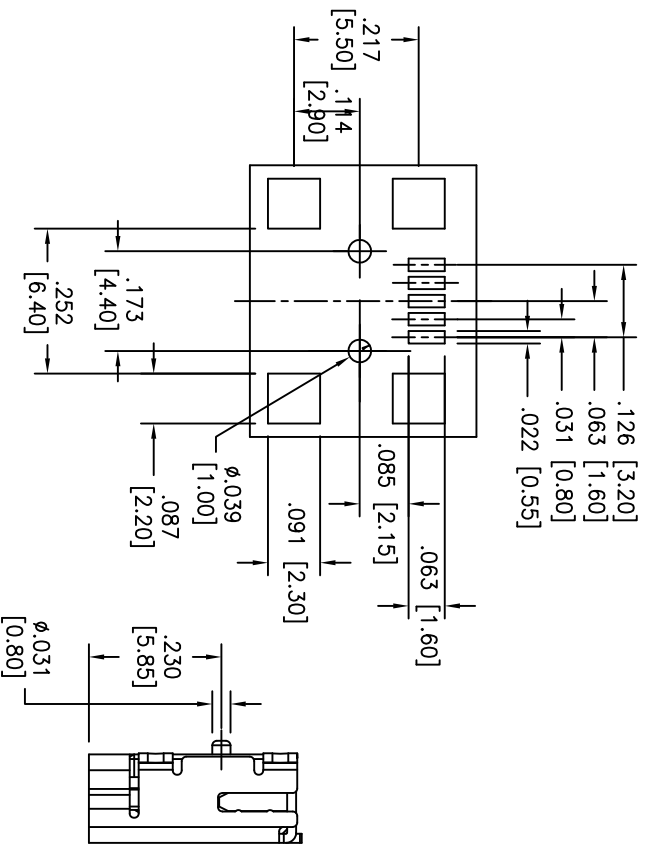
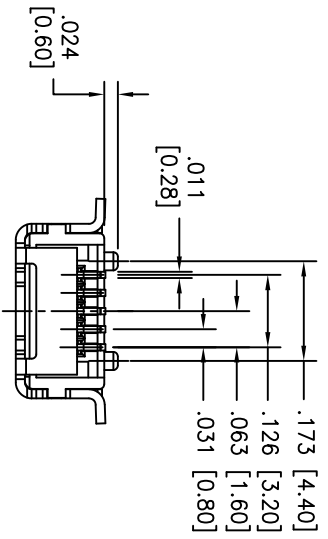

RECOMMENDED PCB LAYOUT

SPECIFICATIONS:

- Material: Insulator: Hi-Temp Nylon PA6T, rated UL 94V-0
- Insulator color: Black
- Contacts: Phosphor Bronze
- Shell: Steel, Nickel plated
- Plating:
- Gold Flash over Nickel underplate on contact area, Tin over Copper underplate on SMT tails
- Environmental:
- Temperature Rating: Lead free, RoHS compliant.
- Recommended soldering temp: 260°C for 5 sec.

UNLESS OTHERWISE SPECIFIED
 ALL DIMENSIONS ARE INCHES [MM]
 TOLERANCES: EXCEPT AS NOTED
 INCHES Holes
 .XX ± .10 ØXX ± .015
 .XX ± .020 ØXX ± .015
 .XXX ± .015 ØXXX ± .010

ADAM TECH
 909 Rahway Avenue, Union, NJ 07083
 Phone: 908-687-5000 Fax: 908-687-5710

APPROVALS	DATE	TITLE	SIZE	PART NO.	SCALE	SHEET	OF
DRAWN	DY	9/14/10	X	MUSB-B5-S-RA-TSMT-HC	NTS	1	1
CHECKED							
APPROVED							

