Introduction

The Atmel® ATA6670-EK development board enables designers to rapidly begin work with this IC and testing and prototyping new LIN designs.

The Atmel ATA6670 is a fully integrated Dual LIN transceiver complying with the LIN specification 2.0, 2.1, and SAEJ2602-2. There are two completely independent and separated Atmel LIN ATA6663 transceivers integrated in a DFN14 package (only the GND pins GND1 and GND2 are internally connected). Each of them interfaces the LIN protocol handler and the physical layer and features three different operating modes: Normal mode, Sleep mode, and Fail-safe mode.

The two LIN transceivers are nearly identical; the only difference is an additional wake-up input and an INH output at transceiver 2. This INH output can be used for measuring the battery voltage.

The device is designed to handle low-speed data communication in vehicles, such as in convenience electronics. Improved slope control at the LIN bus ensures secure data communication up to 20kBaud. Sleep mode guarantees minimal current consumption for each LIN transceiver even in the case of a floating bus line or a short circuit on the LIN bus to GND.

The Atmel ATA6670 has been developed mainly for LIN Master applications.

This document provides a quick start guide on how to use the Atmel ATA6670-EK development board. Please refer to the corresponding datasheet for more detailed information about using the Atmel ATA6670 itself.

Figure 1. The Atmel ATA6670-EK Development Board

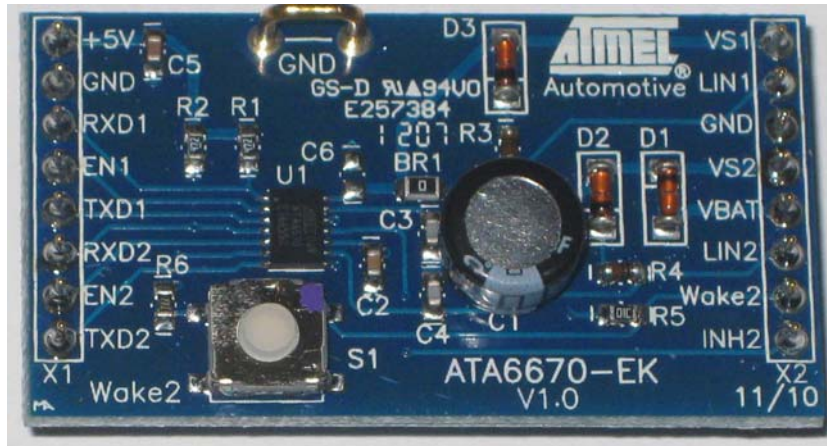

Development Board Features

The development board for the Atmel® ATA6670 supports the following features:

- All necessary components to put the Atmel ATA6670 in operation are mounted
- All pins are easily accessible
- A wake-up pulse can be generated via a switch included on the board (this feature is only available at transceiver 2)
- INH2 output for switching external loads such as a voltage divider for measuring the battery voltage (only available at transceiver 2)

Quick Start

The development board for the Atmel ATA6670 is shipped with all components necessary for rapidly beginning development of LIN Master applications.

Both LIN transceivers inside the Atmel ATA6670 could be supplied separately, but with most applications they are supplied together. That is why the BR1 bridge connecting the supply pins of both LIN transceivers is mounted on the development board. The LIN transceivers are in Fail-safe mode after connecting an external 12V DC power supply between the VBAT and GND terminals. In this mode both LIN pins are in the recessive state and the INH2 output pin of transceiver 2 is switched ON (to the Vs level).

Please note that the communication is still inactive during Fail-safe mode.

In order to communicate via the LIN bus interfaces you have to switch each LIN transceiver to Normal mode by applying 5V at each EN input.

Because the RXD output pins are open drains, the necessary pull-up resistors can be activated by applying for example a +5V DC voltage between the +5V pin and GND on the board.

1. Hardware Description

The following sections contain a brief description of normal operating conditions. Please refer to the datasheet for more information about any of the features mentioned.

The functions described in the following apply to each LIN transceiver. Therefore, if the LIN pin is stated, this applies to each of the two transceivers (LIN1 and LIN2), which work in complete independence of each other. The only internal connection is between GND1 and GND2. The functions available only at transceiver 2 are marked accordingly.

1.1 Power Supply (VBAT, +5V, and GND)

In order to get the development board running, an external 5.7V to 27V DC power supply is required between the VBAT and GND terminals. The input circuit is protected against inverse-polarity by the D1 protection diode, resulting in a difference between VBAT and the VS1 respectively VS2 level of approx. 0.7V.

The DC voltage at the +5V terminal is only needed if the R1 and R2 pull-up resistors for the RXD1 and RXD2 pins are to be activated.

1.2 LIN Interface (LIN, TXD, and RXD)

1.2.1 Bus Pin (LIN)

A low-side driver with internal current limitation and thermal shutdown and an internal pull-up resistor in compliance with LIN spec 2.x are implemented. The internal pull-up resistor is active in Normal and Fail-safe mode. The voltage range is from -27V to +40V. The LIN receiver thresholds comply with the LIN protocol specification.

The fall time and the rise time are slope controlled. The reverse current from the LIN pin to Vs is $< 2\mu\text{A}$ even in the case of a VBAT disconnection.

During a short circuit between the LIN pin and the battery voltage, the output limits the output current. Due to power dissipation, the chip temperature exceeds the overtemperature threshold and the LIN output is switched off. RXD stays high because LIN is high. The chip then cools down and after the temperature hysteresis the LIN output switches on again. The LIN pin is assembled on the board with a 560pF capacitor to GND. Because the LIN transceivers inside the ATA6670 are mainly used in Master nodes, the 1K LIN master pull-up resistor in series with a diode is mounted at LIN1 (D3 and R3) and LIN2 (D2 and R4).

1.2.2 Input/Output Pin (TXD)

In Normal mode the TXD pin is the microcontroller interface for controlling the state of the LIN output. TXD must be at low level in order to have a low LIN bus. If the TXD is high, the LIN output transistor is turned off and the bus is in recessive state. The TXD pin is compatible with both a 3.3V and 5V supply.

The TXD input has an internal pull-down resistor. An internal timer prevents the bus line from being driven permanently in the dominant state. If TXD is forced to low longer than $t_{\text{DOM}} > 70\text{ms}$, the LIN pin is switched off (recessive mode). To reset this mode, switch TXD to high ($> 10\mu\text{s}$) before switching LIN to dominant again.

Only for LIN transceiver 2:

At the LIN transceiver 2, the TXD2 pin is used in Fail-safe mode as an output in order to signal the wake-up source. The LIN transceiver 2 can distinguish between a local wake-up request (WAKE2) and a remote wake-up request (LIN2). The wake-up source can be read at the TXD2 pin in Fail-safe mode. If an external pull-up resistor (typically $5\text{k}\Omega$) has been added on the TXD2 pin to the power supply of the microcontroller, a high level indicates a remote wake-up request (weak pull-down at the TXD2 pin), a low level indicates a local wake-up request (strong pull-down at the TXD2 pin).

The wake-up request flag (indicated at the RXD2 pin) as well as the wake-up source flag (indicated at the TXD2 pin) are reset immediately if the microcontroller sets the EN pin to high.

1.2.3 Output Pin (RXD)

This pin reports the state of the LIN bus to the microcontroller. LIN high (recessive state) is indicated by a high level at RXD; LIN low (dominant state) is reported by a low level at RXD. The short-circuit protected output is an open drain, therefore it is compatible with a 3.3V and 5V power supply.

The two 4.7K resistors R1 and R2 are mounted on the board in order to pull up both RXD open drain outputs.

Please note that the LIN transceivers have to be in Normal mode in order to have the communication via LIN enabled.

1.2.4 Enable Pin (EN)

This pin controls the operation mode of the LIN transceiver. If EN = 1, the LIN transceiver is in Normal mode, with the transmission path from TXD to LIN and from LIN to RXD both active. At a falling edge on EN, while TXD is already set to high, the device is switched to Sleep mode and no transmission is possible. In Sleep mode, the LIN bus pin is pulled up to VS by a weak current source. The device can transmit only after being woken up and switched to Normal mode. During Sleep mode the device is still supplied from the battery voltage. The supply current is typically 10 μ A.

In case the pin is disconnected, the EN pin provides a pull-down resistor in order to force the transceiver into Sleep mode.

1.2.5 WAKE2 Pin (Available at Transceiver 2 Only)

This pin is a high-voltage input used to wake up transceiver 2 from Sleep mode. It is usually connected to an external transistor or a switch to generate a local wake-up.

The S1 switch is mounted on the board to wake up the LIN transceiver 2.

A pull-up current source with typically -10μ A is implemented as well as a debounce timer with a typical debounce time of 35 μ s.

Even if the WAKE2 pin is pulled to GND, it is possible to switch the transceiver 2 to Sleep mode.

If a local wake-up is not needed in the application, the WAKE2 pin can be connected directly to the VS2 pin.

1.2.6 Inhibit Pin (INH2, Available at Transceiver 2 Only)

This pin is used to control an external load such as a voltage divider for measuring the battery voltage, or to switch the external LIN master pull-up resistor on and off at the LIN2 pin. The inhibit pin provides an internal switch towards VS2 which is protected by temperature monitoring. If transceiver 2 is in normal or Fail-safe mode, the INH2 high-side switch is turned on. When transceiver 2 is in Sleep mode, the inhibit switch is turned off, thus disabling the connected external devices.

A wake-up event at LIN2 or at the WAKE2 pin puts the transceiver 2 into Fail-safe mode and as a result the INH2 switches to the VS2 level. After a system power-up (VS2 rises from zero), the INH2 pin switches automatically to the VS2 level.

3. Schematic and Layout of the Atmel ATA6670 Development Board

Figure 3-1. Schematic of the Development Board for the Atmel ATA6670

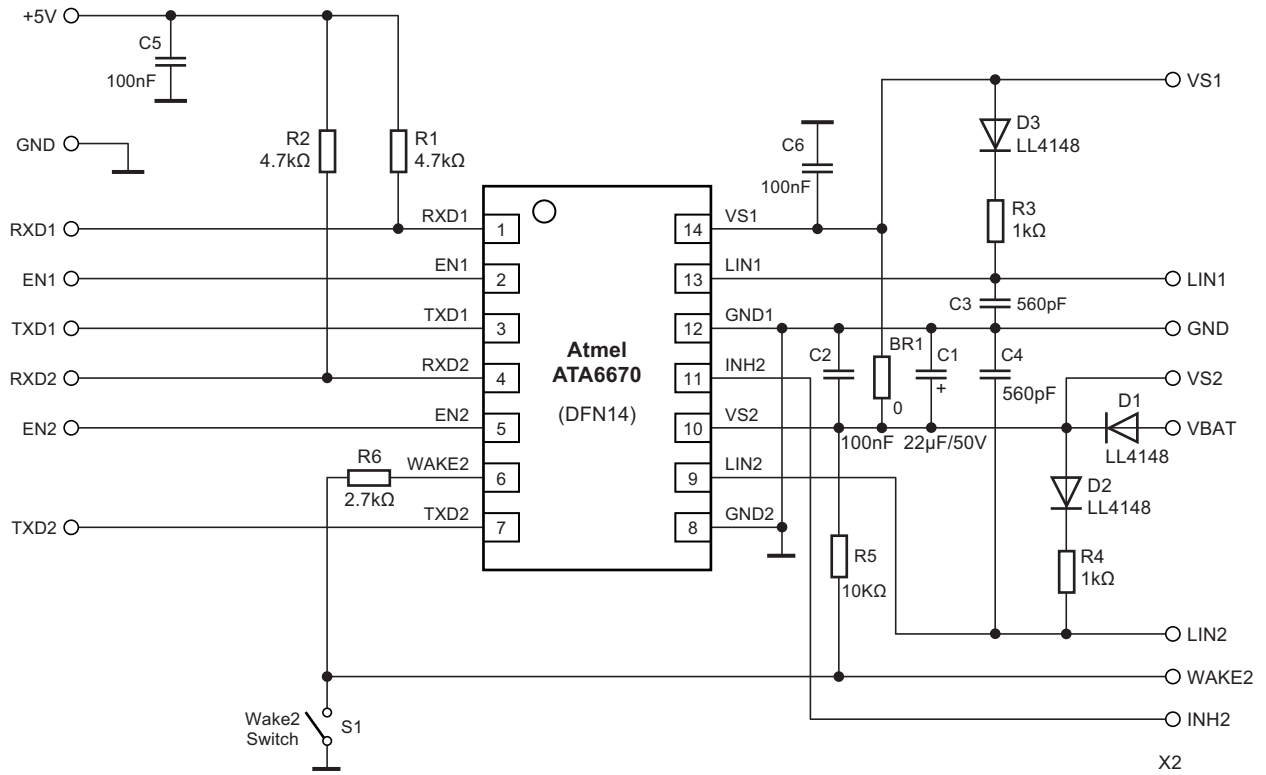

Note: C6 is only needed if the two LIN transceivers inside the Atmel ATA6670 are supplied separately.

Figure 3-2. Board Component Placement - Top Side, Top View

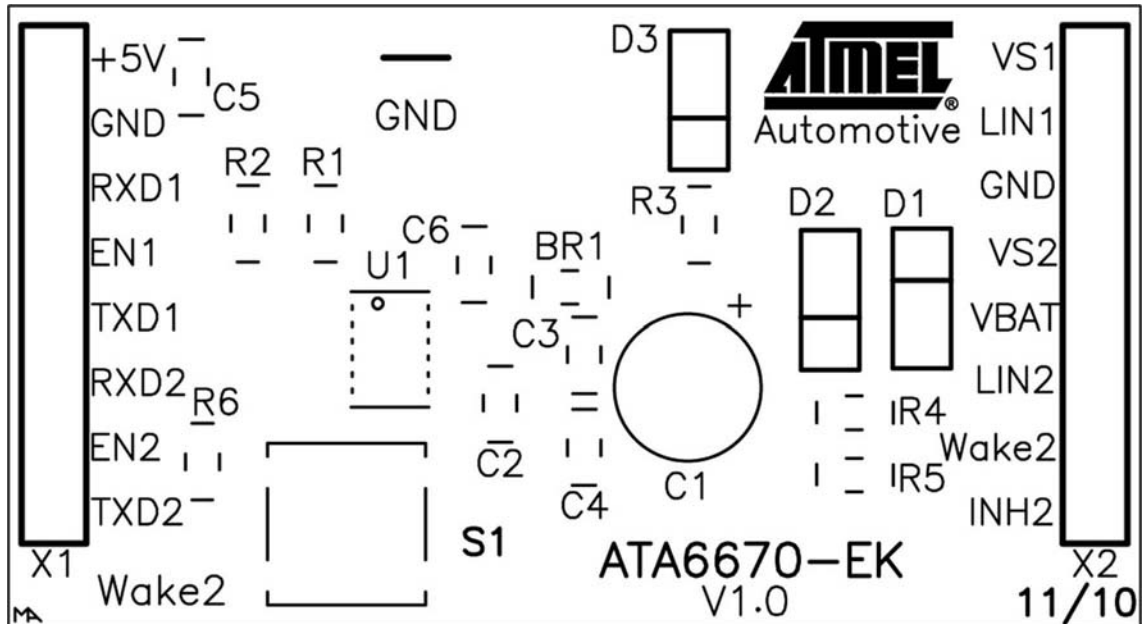

Figure 3-3. Atmel ATA6670 Development Board - Top Side, Top View

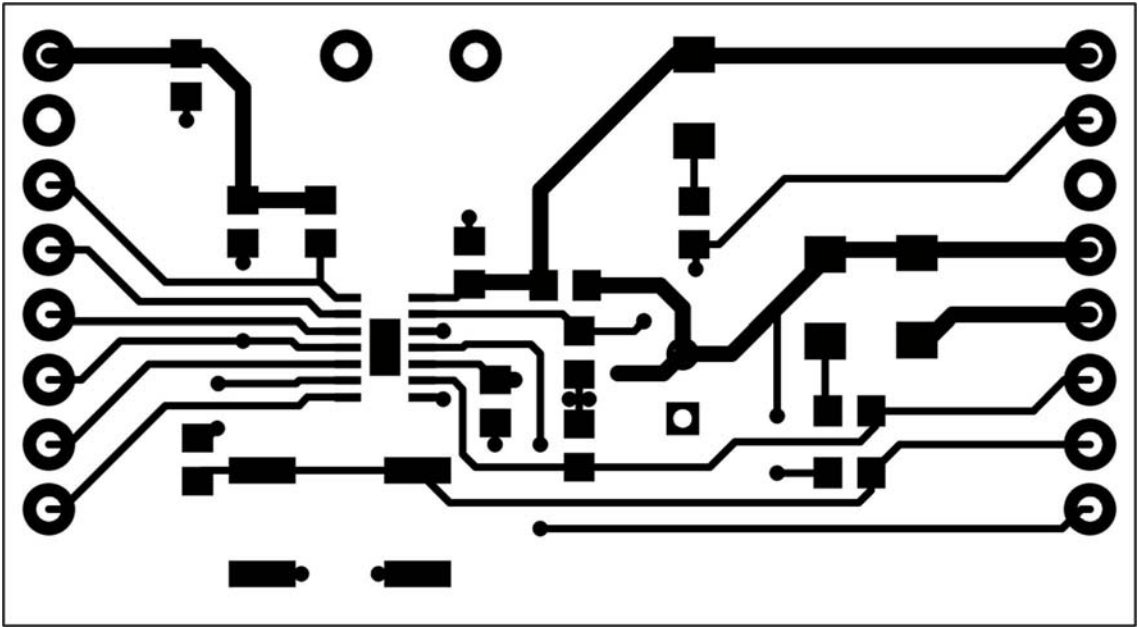
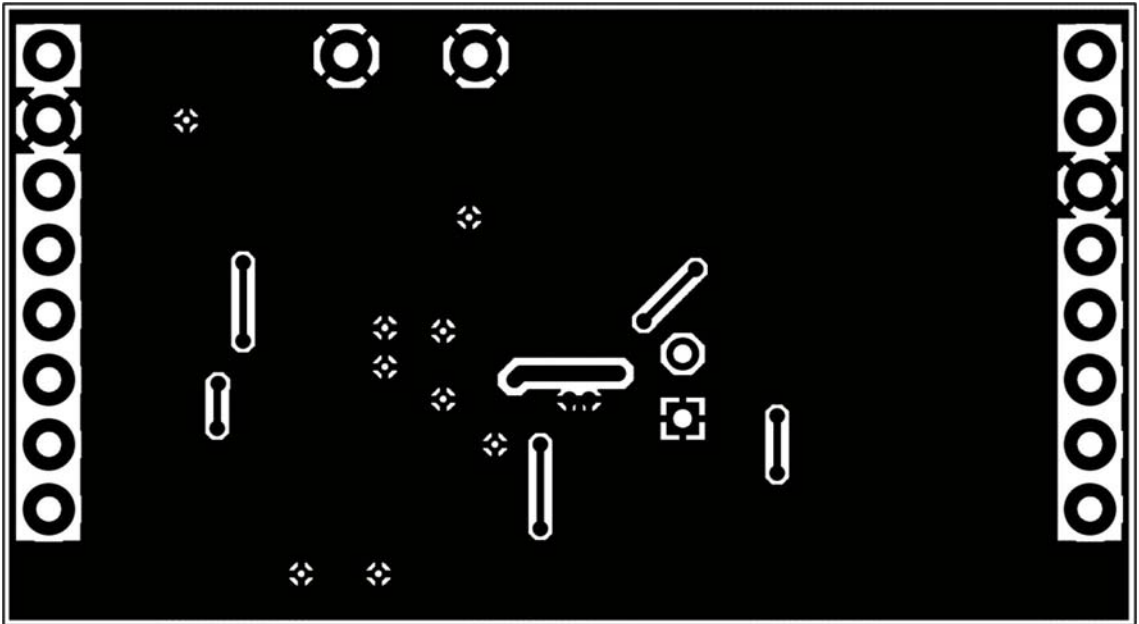

Figure 3-4. Atmel ATA6670 Development Board - Bottom Side, Top View (as if PCB was Transparent)



4. Revision History

Please note that the following page numbers referred to in this section refer to the specific revision mentioned, not to this document.

Revision No.	History
9243B-AUTO-06/15	• Put document in the latest template



Atmel Corporation 1600 Technology Drive, San Jose, CA 95110 USA T: (+1)(408) 441.0311 F: (+1)(408) 436.4200 | www.atmel.com

© 2015 Atmel Corporation. / Rev.: 9243B-AUTO-06/15

Atmel®, Atmel logo and combinations thereof, Enabling Unlimited Possibilities®, and others are registered trademarks or trademarks of Atmel Corporation in U.S. and other countries. Other terms and product names may be trademarks of others.

DISCLAIMER: The information in this document is provided in connection with Atmel products. No license, express or implied, by estoppel or otherwise, to any intellectual property right is granted by this document or in connection with the sale of Atmel products. EXCEPT AS SET FORTH IN THE ATMEL TERMS AND CONDITIONS OF SALES LOCATED ON THE ATMEL WEBSITE, ATMEL ASSUMES NO LIABILITY WHATSOEVER AND DISCLAIMS ANY EXPRESS, IMPLIED OR STATUTORY WARRANTY RELATING TO ITS PRODUCTS INCLUDING, BUT NOT LIMITED TO, THE IMPLIED WARRANTY OF MERCHANTABILITY, FITNESS FOR A PARTICULAR PURPOSE, OR NON-INFRINGEMENT. IN NO EVENT SHALL ATMEL BE LIABLE FOR ANY DIRECT, INDIRECT, CONSEQUENTIAL, PUNITIVE, SPECIAL OR INCIDENTAL DAMAGES (INCLUDING, WITHOUT LIMITATION, DAMAGES FOR LOSS AND PROFITS, BUSINESS INTERRUPTION, OR LOSS OF INFORMATION) ARISING OUT OF THE USE OR INABILITY TO USE THIS DOCUMENT, EVEN IF ATMEL HAS BEEN ADVISED OF THE POSSIBILITY OF SUCH DAMAGES. Atmel makes no representations or warranties with respect to the accuracy or completeness of the contents of this document and reserves the right to make changes to specifications and products descriptions at any time without notice. Atmel does not make any commitment to update the information contained herein. Unless specifically provided otherwise, Atmel products are not suitable for, and shall not be used in, automotive applications. Atmel products are not intended, authorized, or warranted for use as components in applications intended to support or sustain life.

SAFETY-CRITICAL, MILITARY, AND AUTOMOTIVE APPLICATIONS DISCLAIMER: Atmel products are not designed for and will not be used in connection with any applications where the failure of such products would reasonably be expected to result in significant personal injury or death ("Safety-Critical Applications") without an Atmel officer's specific written consent. Safety-Critical Applications include, without limitation, life support devices and systems, equipment or systems for the operation of nuclear facilities and weapons systems. Atmel products are not designed nor intended for use in military or aerospace applications or environments unless specifically designated by Atmel as military-grade. Atmel products are not designed nor intended for use in automotive applications unless specifically designated by Atmel as automotive-grade.