



FEATURES:

- Suitable for RoHS reflow profile
- High current rating and low DCR
- Special lead wire design to prevent open circuit failure
- Excellent terminal strength to mechanical stress

APPLICATIONS:

- OA equipments
- PC and notebook
- LCD TV set
- Power supply

ELECTRICAL SPECIFICATIONS:

Abracon P/N:	ASPI-0703 Series
Operating Temperature:	-40°C to +85°C
Storage Temperature:	+5°C to +40°C

PART NUMBER	INDUCTANCE (µH)	Tolerance	DCR(Ω) max	IDC (A) max	Inductance Code
ASPI-0703-100	10	K	0.081	1.44	100
ASPI-0703-120	12	K	0.090	1.39	120
ASPI-0703-150	15	K	0.104	1.24	150
ASPI-0703-180	18	K	0.111	1.12	180
ASPI-0703-220	22	K	0.129	1.07	220
ASPI-0703-270	27	K	0.153	0.94	270
ASPI-0703-330	33	K	0.170	0.85	330
ASPI-0703-390	39	K	0.217	0.74	390
ASPI-0703-470	47	K	0.252	0.68	470
ASPI-0703-560	56	K	0.282	0.64	560
ASPI-0703-680	68	K	0.332	0.59	680
ASPI-0703-820	82	K	0.406	0.54	820
ASPI-0703-101	100	K	0.481	0.51	101
ASPI-0703-121	120	K	0.536	0.49	121
ASPI-0703-151	150	K	0.755	0.40	151
ASPI-0703-181	180	K	1.022	0.36	181
ASPI-0703-221	220	K	1.200	0.31	221
ASPI-0703-271	270	K	1.306	0.29	271
ASPI-0703-331	330	K	1.495	0.28	331

Test Conditions

Inductance: 100kHz

Isat: $\Delta L/L$ (initial) $\geq -10\%$ or $\Delta T=40^\circ\text{C}$ ($T_a=20^\circ\text{C}$), whichever is lower.

OPTIONS AND PART IDENTIFICATION

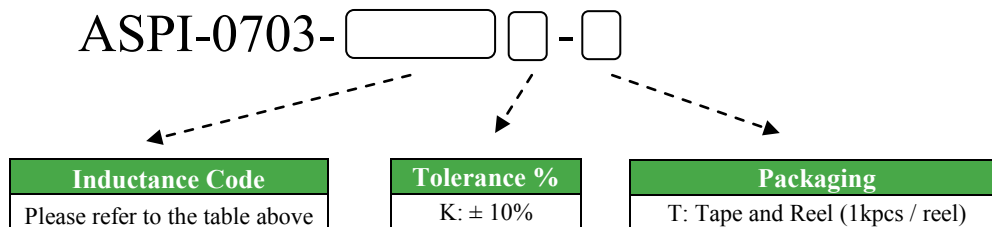



OUTLINE DRAWING:

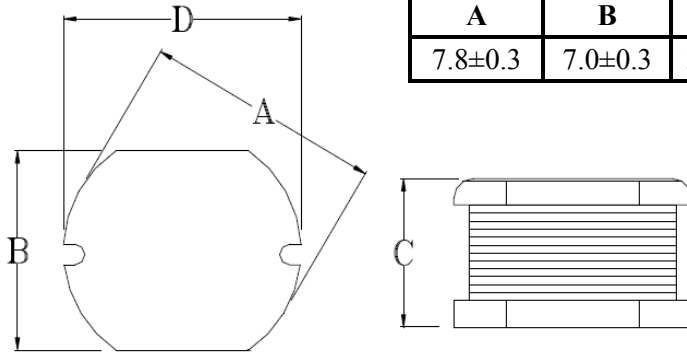

A	B	C	D	E	F	G
7.8±0.3	7.0±0.3	3.5±0.50	7.8±0.3	3.00	2.00	7.50

Recommended Land Pattern

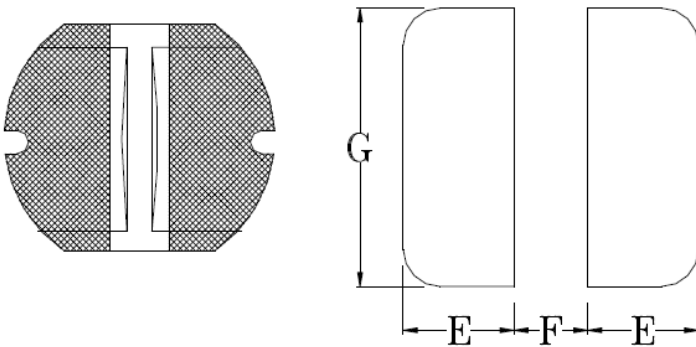

Dimension: mm

REFLOW PROFILE:

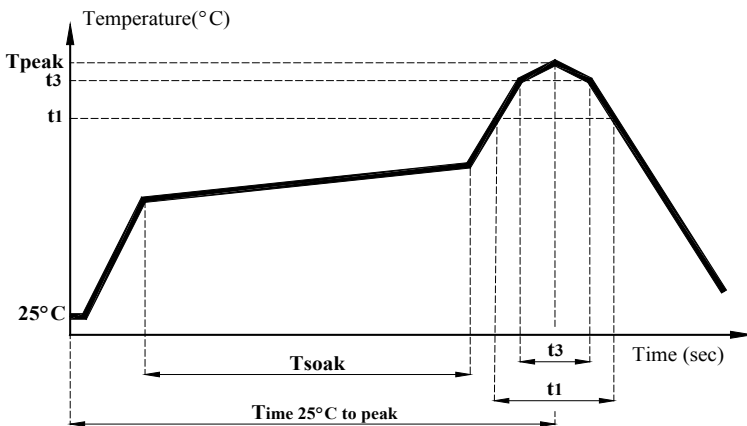

Item	mark	
Temperature rise gradient		3°C/sec (max)
Heating time	Tsoak	50s ~ 150s
Heating temperature		120°C~180°C
Time over 217°C	t1	70 sec
Time within 5°C of actual peak temperature	t3	10~30 sec
Peak temperature	Tpeak	250 (+0 / -5 °C)
Time 25°C to peak Temperature		6 minutes max.



TAPE & REEL:

T: 1,000pcs / reel

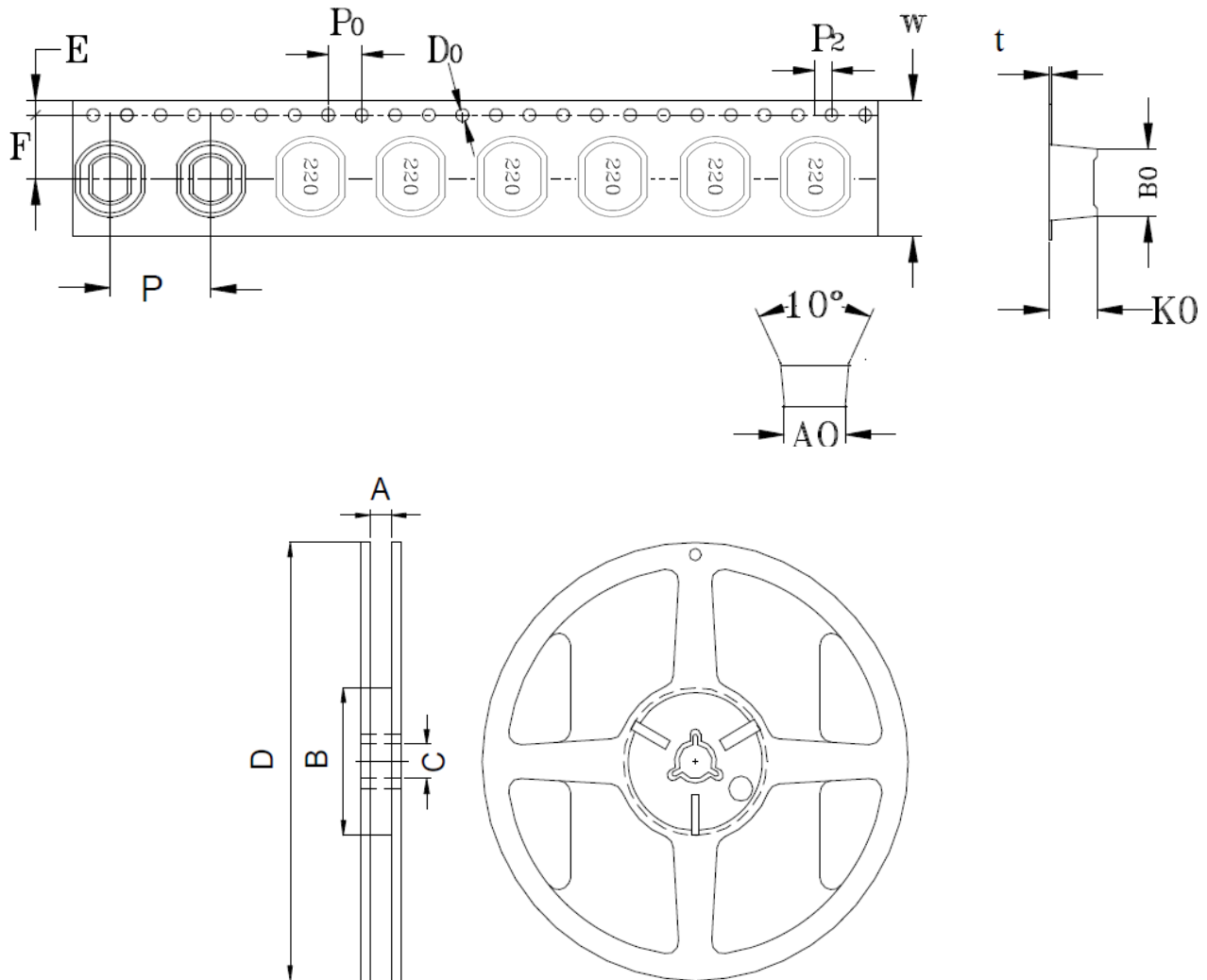

CARRIER TAPE / SIZE (mm)										REEL 13"×16mm			
A0	B0	K0	F	E	W	P	P ₀	P ₂	t	A	B	C	D
7.2 ± 0.1	7.85 ± 0.1	4.1 ± 0.1	7.5 ± 0.1	1.75 ± 0.1	16 ± 0.3	12 ± 0.1	4 ± 0.1	2 ± 0.1	0.35 ± 0.05	16.5 ± 0.5	100 ± 0.5	13.2 ± 0.3	330 ± 1.0

Dimension: mm

ATTENTION Abracon Corporation's products are COTS – Commercial-Off-The-Shelf products; suitable for Commercial, Industrial and, where designated, Automotive Applications. Abracon's products are not specifically designed for Military, Aviation, Aerospace, Life-dependant Medical applications or any application requiring high reliability where component failure could result in loss of life and/or property. For applications requiring high reliability and/or presenting an extreme operating environment, written consent and authorization from Abracon Corporation is required. Please contact Abracon Corporation for more information.