

January 29, 1998

TEL:805-498-2111 FAX:805-498-3804 WEB:http://www.semtech.com

DESCRIPTION

The SC1631 is a high efficiency step up DC-DC converter. Only four external components are required to deliver a fixed voltage of 3V, 3.3V, or 5V. Efficiency beyond 87% can be easily achieved at 100mA load with 2.2V to 3V input voltages.

A logic-controlled shutdown mode is provided for power saving. Switch current limit can be programmed with a resistor. The low battery detector can be configured as a linear regulator or a burst mode controller providing extremely low supply current operation.

A switching rate of 120kHz reduces the inductor size - inductors of 25 μ H to 50 μ H are recommended for most applications.

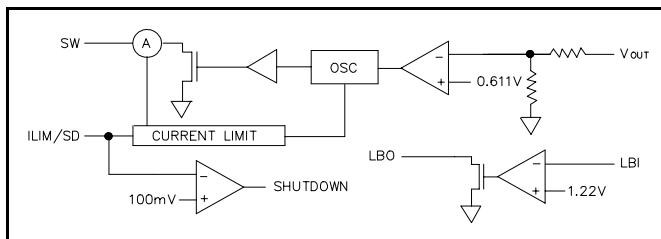
FEATURES

- High efficiency 90%
- Power-saving shutdown mode (7 μ A typical)
- Internal 2A switch
- 120kHz switching rate
- Adjustable switch current limit
- On-chip low battery detector

APPLICATIONS

- Palmtop and notebook computers
- Pocket organizers
- Cameras
- Pagers
- Battery backup supplies
- Portable instruments

BLOCK DIAGRAM



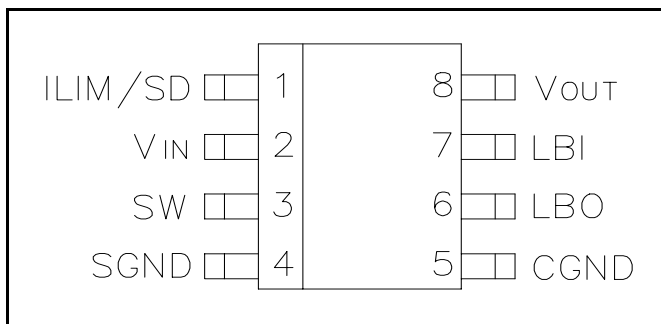
ORDERING INFORMATION

DEVICE ⁽¹⁾	OUTPUT VOLTAGE	PACKAGE
SC1631CS	3.3V	SO-8
SC1631-3CS	3.0V	
SC1631-5CS	5.0V	

Note:

(1) Add suffix 'TR' for tape and reel.

PIN CONFIGURATION



ABSOLUTE MAXIMUM RATINGS

Parameter	Symbol	Maximum	Units
Supply Voltage	V_{IN}	7.0	V
Operating Temperature Range	T_A	0 to 70	$^{\circ}$ C
Storage Temperature Range	T_{STG}	-65 to 125	$^{\circ}$ C

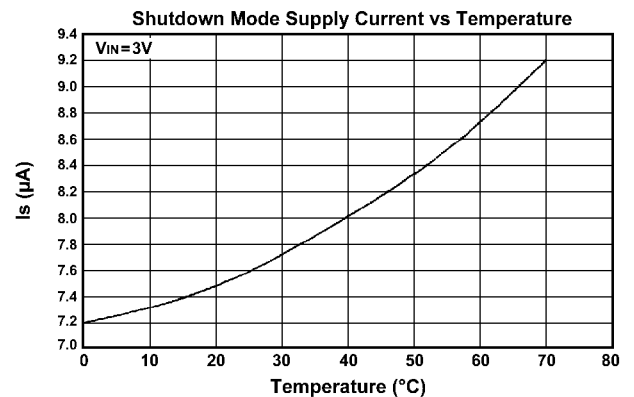
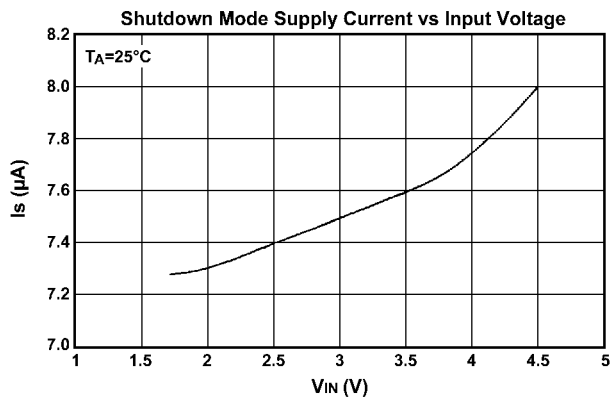
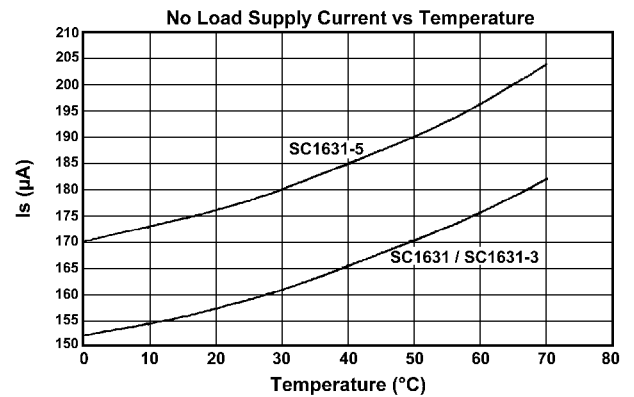
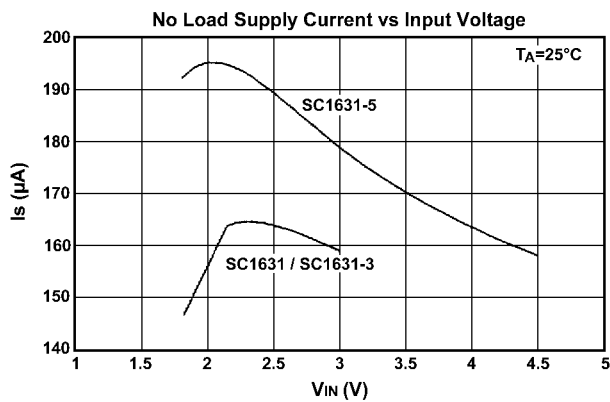
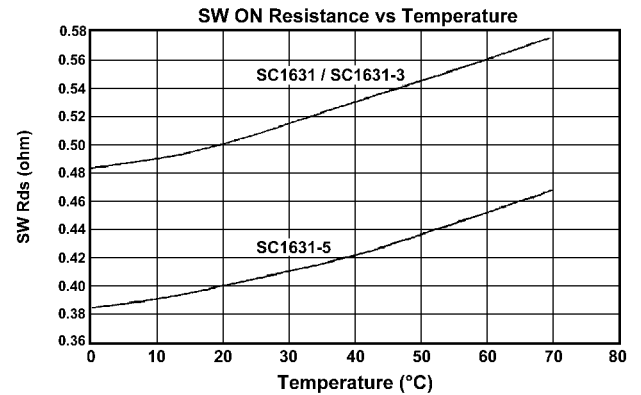
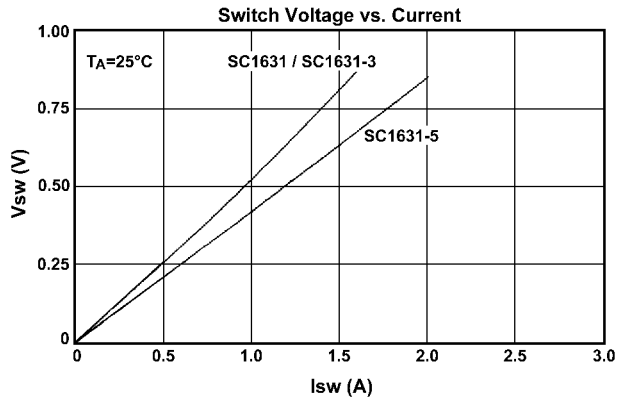
January 29, 1998

ELECTRICAL CHARACTERISTICS

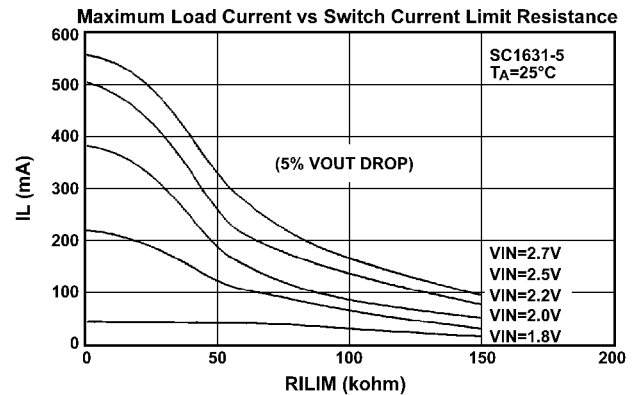
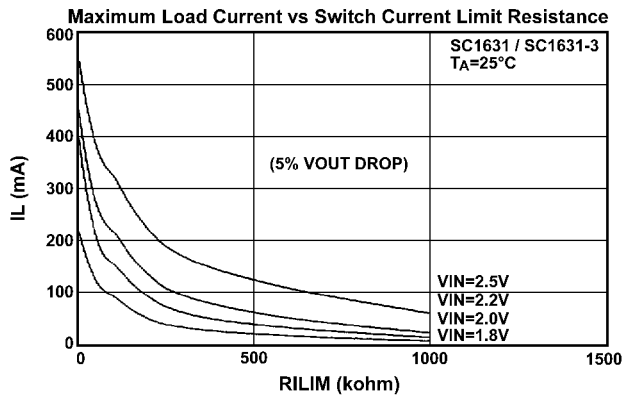
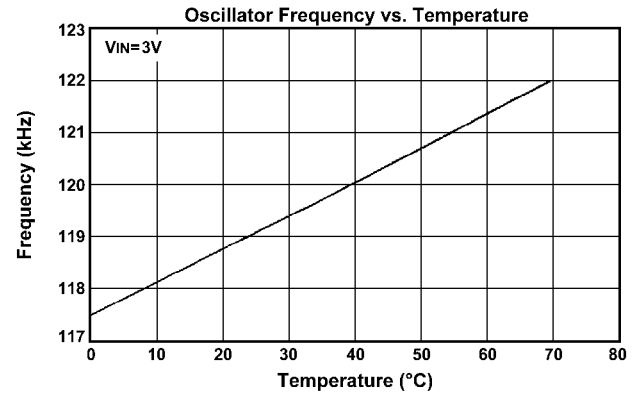
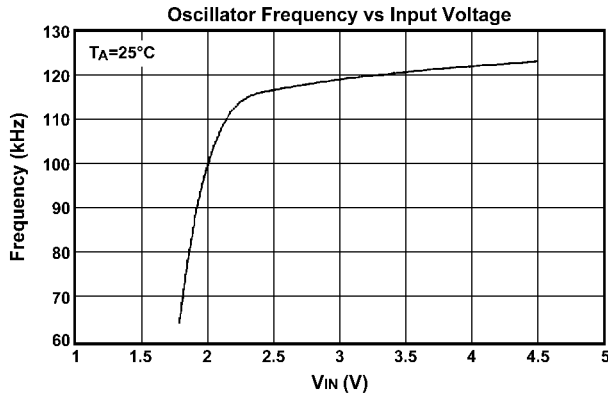
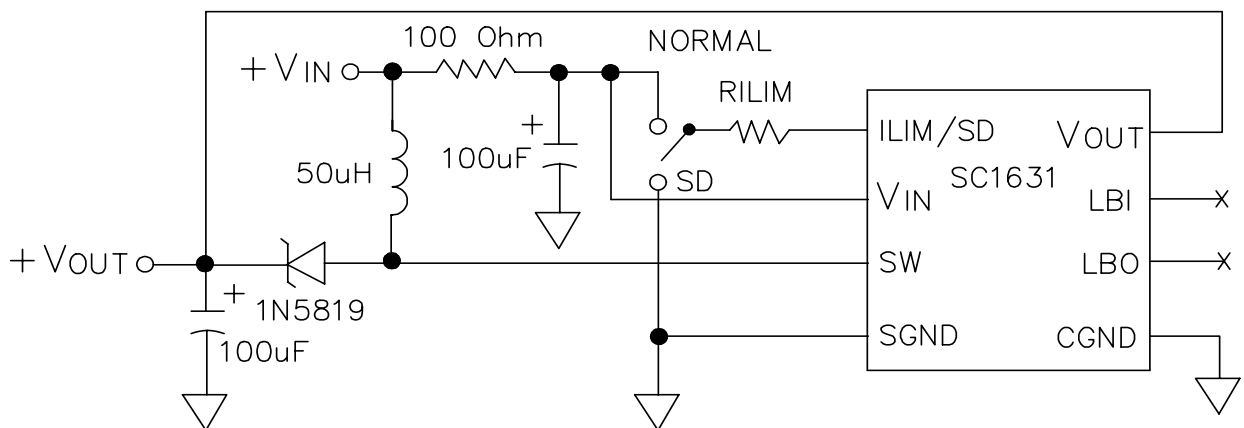
 Unless otherwise specified, $T_A = 25^\circ\text{C}$, $V_{IN} = 3.0\text{V}$

Parameter	Test Conditions		Test Limits			Units
	V_{IN}	I_L	Min	Typ	Max	
Input Voltage			1.5		7.0	V
Output Voltage SC1631 SC1631-3 SC1631-5		$I_L = 200\text{mA}$	3.16 2.88 4.80	3.30 3.00 5.00	3.44 3.12 5.20	V
Switch Off Current				105	140	μA
No Load Current SC1631/SC1631-3 SC1631-5				160 180		μA
Shutdown Mode Current				7	15	μA
Recovery Time from Shutdown	$V_{IN}=2.5\text{V}$	$I_L=200\text{mA}$		0.4		ms
Efficiency SC1631/SC1631-3 SC1631-5		$I_L=200\text{mA}$		87 90		%
Line Regulation SC1631 SC1631-3 SC1631-5	$V_{IN}=1.8 - 3.3\text{V}$ $V_{IN}=1.8 - 3.0\text{V}$ $V_{IN}=2.2 - 3.3\text{V}$	$I_L=100\text{mA}$		0.6 0.5 0.8		$\%V_{OUT}$
Load Regulation SC1631/SC1631-3 SC1631-5		$I_L=10\text{mA} - 300\text{mA}$		0.3 0.8		$\%V_{OUT}$
Oscillator Frequency			90	120	150	kHz
LBI Pin Trip Point			1.17	1.22	1.27	V
LBO "On Resistance"	$V_{IN} = 2\text{V}$			45		Ω
SW "On Resistance" SC1631/SC1631-3 SC1631-5				0.5 0.4		Ω
SW Off Leakage					1	μA
Input Pin Bias Current					10	nA/Pin
Output Pin Leakage					10	nA/Pin

January 29, 1998

TYPICAL PERFORMANCE CHARACTERISTICS


January 29, 1998

TYPICAL PERFORMANCE CHARACTERISTICS (cont.)

TYPICAL APPLICATION CIRCUIT


January 29, 1998

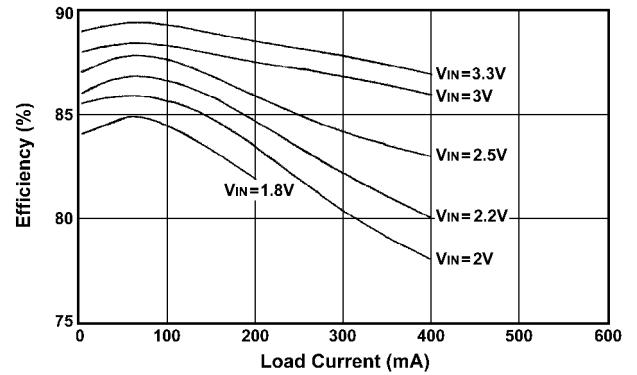
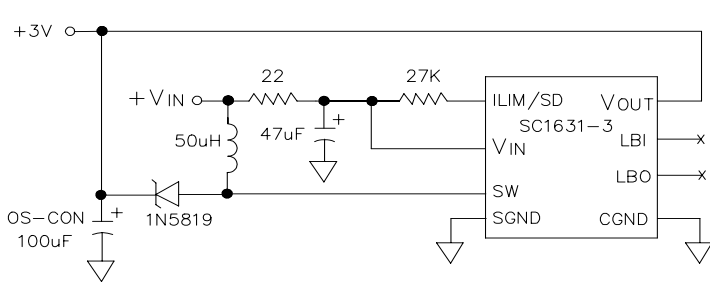
APPLICATION EXAMPLES


Figure 1. 3V Output Step-Up Converter

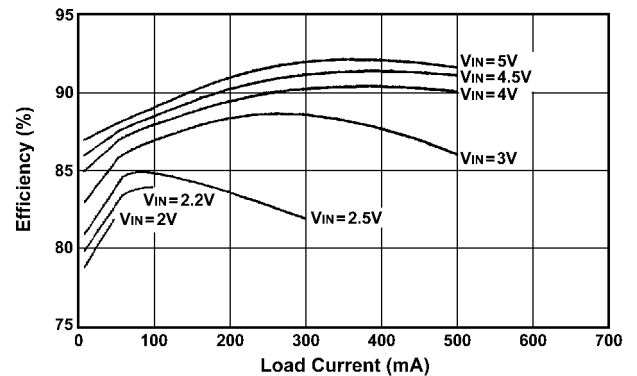
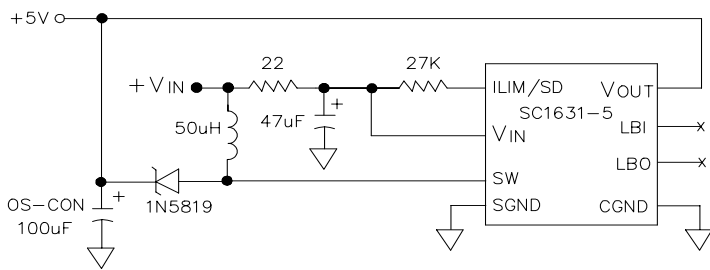


Figure 2. 5V Output Step-Up Converter

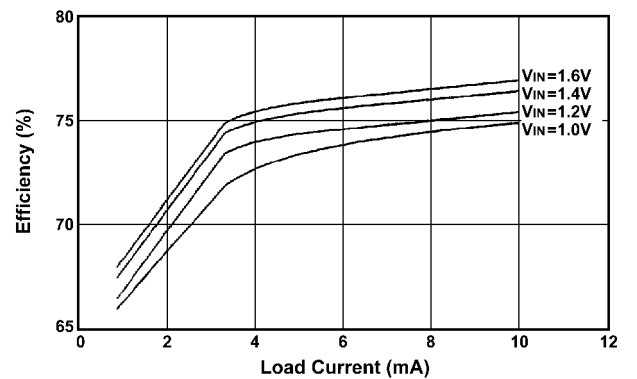
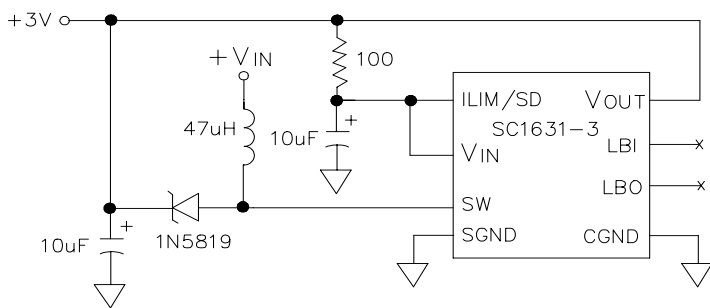


Figure 3. 1-Cell Input 3V Output Step-Up Converter

January 29, 1998

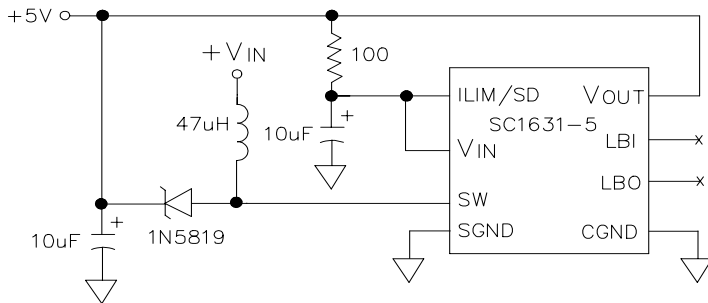
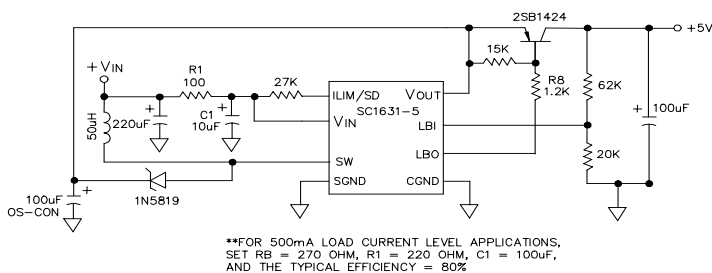
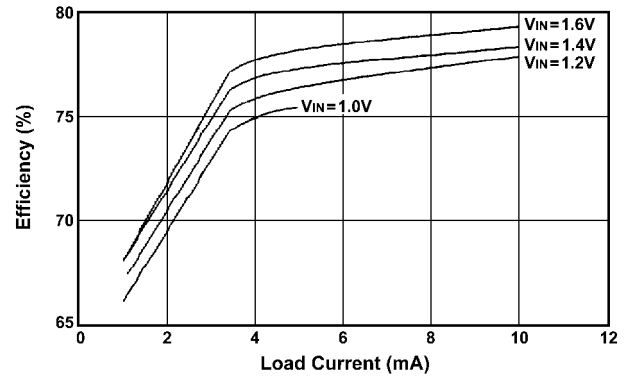
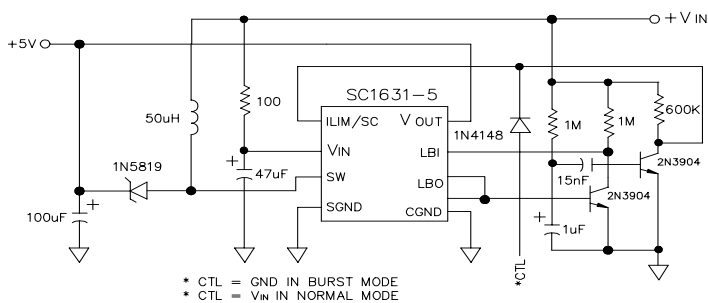
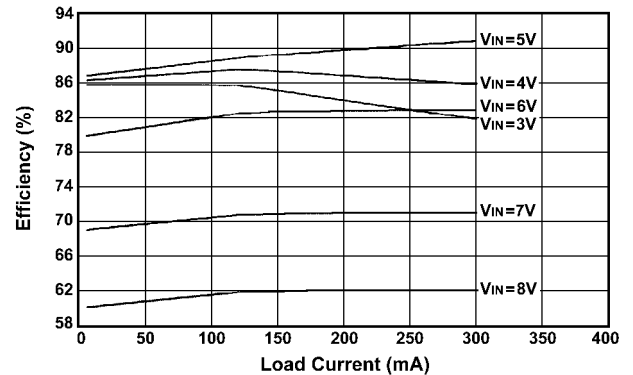
APPLICATION EXAMPLES (cont.)


Figure 4. 1-Cell Input 5V Output Step-Up Converter



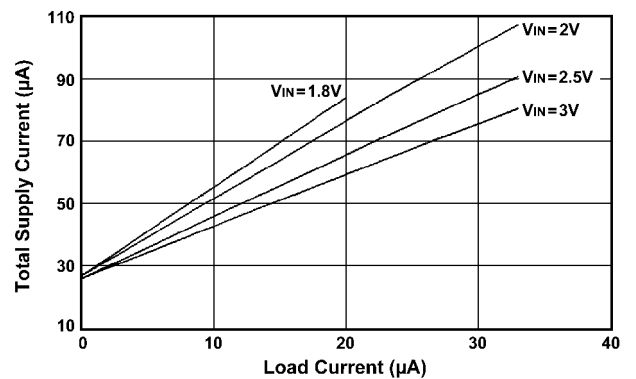
**FOR 500mA LOAD CURRENT LEVEL APPLICATIONS,
SET RB = 270 OHM, R1 = 220 OHM, C1 = 100uF,
AND THE TYPICAL EFFICIENCY = 80%

Figure 5. 4-Cell Input Step-Up/Step-Down Converter

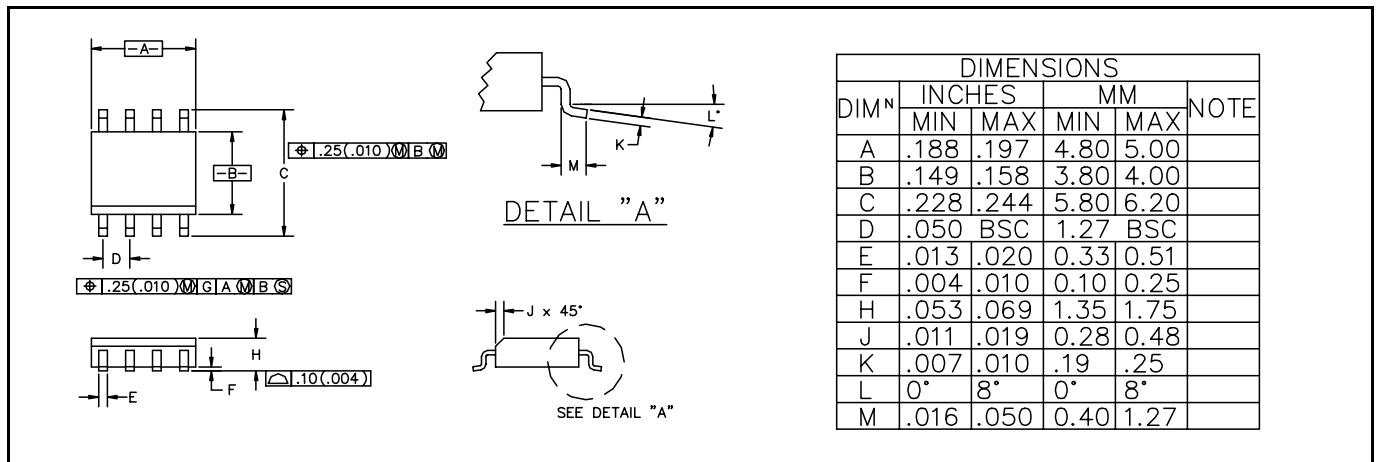


* CTL = GND IN BURST MODE
* CTL = VIN IN NORMAL MODE

Figure 6. Low Supply Current Burst Mode Step-Up Converter



January 29, 1998

DEVICE OUTLINE - SO-8

PIN DESCRIPTIONS

PIN 1: I_{LIM}/SD (1) Connected to V_{IN} pin through a resistor to set the switch peak current. It serves to protect the IC and inductor, as well as to improve efficiency and output ripple. However, the supply capability of the SC1631 is limited by the current limit resistor (see typical performance characteristics). The I_{LIM}/SD pin should be shorted to V_{IN} if limiting switch peak current is not required. (2) The SC1631 goes into shutdown mode and consumes less than $10\mu A$ when the I_{LIM}/SD pin is pulled to ground.

PIN 2: V_{IN} Input supply.

PIN 3: SW Drain of the power switch, to be connected to the inductor and diode.

PIN 4: SGND Ground connected to the source of the power switch.

PIN 5: CGND Ground for control circuits of the IC. It should be separated from SGND to avoid interference.

PIN 6: LBO Open drain output of the battery low detector, with 45 Ohm "On Resistance" at $V_{IN}=2V$. It is pulled low when the voltage on the LBI pin is below 1.22 volts.

PIN 7: LBI The inverting input of the battery low detector, of which the non-inverting input is internally connected to the 1.22V voltage reference.

PIN 8: V_{OUT} The output voltage feeds back to the IC through this pin.

PIN CONFIGURATION
