

# SDS01 SDH01 SERIES

DC-DC CONVERTER

2:1 WIDE INPUT RANGE  
UP TO 1.08 WATTS

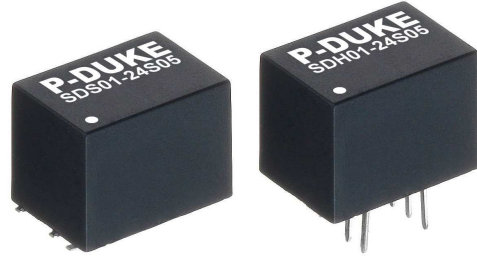

## FEATURES

- ULTRA SMALL SMD AND DIP PACKAGE, 0.52 x 0.36 x 0.40 INCH WITH REGULATED
- SMD PACKAGE QUALIFIED FOR LEADFREE REFLOW SOLDER PROCESS ACCORDING IPC J-STD-020D
- NO MINIMUM LOAD REQUIRED
- CONTINUOUS SHORT CIRCUIT PROTECTION
- 1600VDC INPUT TO OUTPUT ISOLATION AND 3000VDC FOR OPTION
- SAFETY MEETS UL60950-1, EN60950-1, & IEC60950-1
- CE MARKED
- COMPLIANT TO RoHS II & REACH

## APPLICATIONS

- WIRELESS NETWORK
- TELECOM/DATACOM
- INDUSTRY CONTROL SYSTEM
- MEASUREMENT EQUIPMENT
- SEMICONDUCTOR EQUIPMENT

<b>3000VDC ISOLATION</b>	<b>1600VDC ISOLATION</b>	<b>REMOTE CONTROL</b>	<b>SCP</b>
------------------------------	------------------------------	---------------------------	------------

## TECHNICAL SPECIFICATION

All specifications are typical at nominal input, full load and 25°C otherwise noted

Model Number	Input Range	Output Voltage	Output Current @ Full Load	Input Current @ No Load	Efficiency	Maximum Capacitor Load
	VDC	VDC	mA	mA	%	µF
SDS(H)01-05S3P3	4.5 ~ 9	3.3	300	20	78	1680
SDS(H)01-05S05	4.5 ~ 9	5	200	25	80	820
SDS(H)01-05S12	4.5 ~ 9	12	90	30	83	470
SDS(H)01-05S15	4.5 ~ 9	15	70	30	83	330
SDS(H)01-05S24	4.5 ~ 9	24	45	30	82	160
SDS(H)01-05D05	4.5 ~ 9	±5	±100	30	81	±470
SDS(H)01-05D12	4.5 ~ 9	±12	±45	30	82	±330
SDS(H)01-05D15	4.5 ~ 9	±15	±35	30	82	±220
SDS(H)01-12S3P3	9 ~ 18	3.3	300	10	78	1680
SDS(H)01-12S05	9 ~ 18	5	200	10	80	820
SDS(H)01-12S12	9 ~ 18	12	90	13	83	470
SDS(H)01-12S15	9 ~ 18	15	70	13	83	330
SDS(H)01-12S24	9 ~ 18	24	45	15	82	160
SDS(H)01-12D05	9 ~ 18	±5	±100	15	80	±470
SDS(H)01-12D12	9 ~ 18	±12	±45	15	82	±330
SDS(H)01-12D15	9 ~ 18	±15	±35	15	82	±220
SDS(H)01-24S3P3	18 ~ 36	3.3	300	6	78	1680
SDS(H)01-24S05	18 ~ 36	5	200	6	81	820
SDS(H)01-24S12	18 ~ 36	12	90	6	83	470
SDS(H)01-24S15	18 ~ 36	15	70	6	83	330
SDS(H)01-24S24	18 ~ 36	24	45	8	82	160
SDS(H)01-24D05	18 ~ 36	±5	±100	8	80	±470
SDS(H)01-24D12	18 ~ 36	±12	±45	8	82	±330
SDS(H)01-24D15	18 ~ 36	±15	±35	8	82	±220
SDS(H)01-48S3P3	36 ~ 75	3.3	300	5	79	1680
SDS(H)01-48S05	36 ~ 75	5	200	5	80	820
SDS(H)01-48S12	36 ~ 75	12	90	5	82	470
SDS(H)01-48S15	36 ~ 75	15	70	5	83	330
SDS(H)01-48S24	36 ~ 75	24	45	5	82	160
SDS(H)01-48D05	36 ~ 75	±5	±100	5	80	±470
SDS(H)01-48D12	36 ~ 75	±12	±45	5	82	±330
SDS(H)01-48D15	36 ~ 75	±15	±35	5	81	±220

**PART NUMBER STRUCTURE**

**SDS01 - 48 S 05 H**

Series Name	Input Voltage (VDC)	Output Quantity	Output Voltage (VDC)	Isolation Option
<b>SDS:</b> SMD type <b>SDH:</b> DIP type	<b>05:</b> 4.5~9 <b>12:</b> 9~18 <b>24:</b> 18~36 <b>48:</b> 36~75	<b>S:</b> Single	<b>3P3:</b> 3.3 <b>05:</b> 5 <b>12:</b> 12 <b>15:</b> 15 <b>24:</b> 24	<input type="checkbox"/> : Standard type 1600VDC isolation <b>H:</b> 3000VDC isolation
		<b>D:</b> Dual	<b>05:</b> ± 5 <b>12:</b> ± 12 <b>15:</b> ± 15	

**INPUT SPECIFICATIONS**

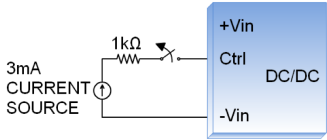
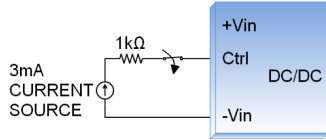
Parameter	Conditions	Min.	Typ.	Max.	Unit
Operating input voltage range	5Vin(nom)	4.5	5	9	VDC
	12Vin(nom)	9	12	18	
	24Vin(nom)	18	24	36	
	48Vin(nom)	36	48	75	
Start up time	Constant resistive load Power up Remote ON/OFF		5	10	ms
			5	10	
Input surge voltage	1 second, max.			15	VDC
				25	
				50	
				100	
Input reflected ripple current <sup>(1)</sup>	5Vin(nom) 12Vin(nom) 24Vin(nom) 48Vin(nom)		10		mA <sub>p-p</sub>
			10		
			10		
			10		
Input filter		Capacitor type			
Remote ON/OFF	Ctrl pin applied current via 1kΩ DC-DC ON DC-DC OFF Remote off input current	Open or high impedance			mA
		2.0	3.0	4.0	2.5
<p>Application circuit</p> <p>DC-DC ON</p>  <p>DC-DC OFF</p> 					

**OUTPUT SPECIFICATIONS**

Parameter	Conditions	Min.	Typ.	Max.	Unit	
Voltage accuracy		-1.0		+1.0	%	
Line regulation	Low Line to High Line at Full Load	-0.2		+0.2	%	
Load regulation	No Load to Full Load	Single		+1.0	%	
		Dual		+1.0		
	10% Load to 90% Load	Single	-0.5			+0.5
		Dual	-0.8			+0.8
Cross regulation	Asymmetrical load 25%/100% FL	-5.0		+5.0	%	
Ripple and noise	Measured by 20MHz bandwidth		30		mV <sub>p-p</sub>	
Temperature coefficient		-0.02		+0.02	%/°C	
Transient response recovery time	25% load step change		500		μs	
Short circuit protection		Continuous, automatic recovery				

**GENERAL SPECIFICATIONS**

Parameter	Conditions		Min.	Typ.	Max.	Unit
Isolation voltage	1 minute	Standard Suffix "H"	1600			VDC
Isolation resistance	500VDC		3000			GΩ
Isolation capacitance		Standard Suffix "H"			50 50	pF
Switching frequency			100			kHz
Safety meets						UL60950-1 EN60950-1 IEC60950-1
Case material						Non-conductive black plastic
Base material						Non-conductive black plastic
Potting material						Silicone (UL94 V-0)
Weight						2.7g (0.10oz)
MTBF	MIL-HDBK-217F, Full load					8.534 x 10 <sup>6</sup> hrs

**ENVIRONMENTAL SPECIFICATIONS**

Parameter	Conditions		Min.	Typ.	Max.	Unit
Operating ambient temperature		Without derating With derating	-40 +90		+90 +105	°C
Storage temperature range			-55		+125	°C
Thermal shock						MIL-STD-810F
Vibration						MIL-STD-810F
Relative humidity						5% to 95% RH
Lead-free reflow solder process						IPC J-STD-020D
Moisture sensitivity level(MSL)						IPC J-STD-033B Level 2

**EMC SPECIFICATIONS**

Parameter	Conditions		Level
EMI (1)	EN55022		Class A, Class B
ESD	EN61000-4-2	Air ± 8kV Contact ± 6kV	Perf. Criteria A
Radiated immunity	EN61000-4-3	10 V/m	Perf. Criteria A
Fast transient (2)	EN61000-4-4	± 2kV	Perf. Criteria A
Surge (2)	EN61000-4-5	± 1kV	Perf. Criteria A
Conducted immunity	EN61000-4-6	10 Vr.m.s	Perf. Criteria A
Power frequency magnetic field	EN61000-4-8	100A/m continuous; 1000A/m 1 second	Perf. Criteria A

**Note:**

- The standard module meets EMI Class A or Class B and input reflected ripple current with external components. For further information, please contact with P-DUKE.
- An external input filter capacitor is required if the module has to meet EN61000-4-4, EN61000-4-5. The filter capacitor Power Mate suggest: Nippon chemi-con KY series, 220 µF/100V.

**CAUTION:** This power module is not internally fused. An input line fuse must always be used.

**CHARACTERISTIC CURVE**

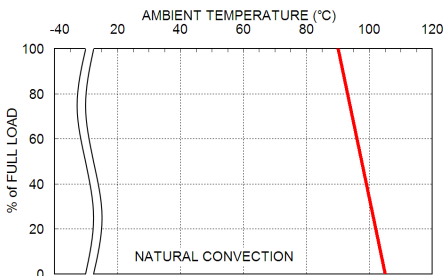

SDS(H)01-48S05 Derating Curve

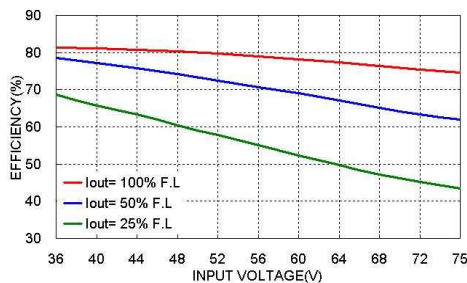

SDS(H)01-48S05 Efficiency vs. Input Voltage

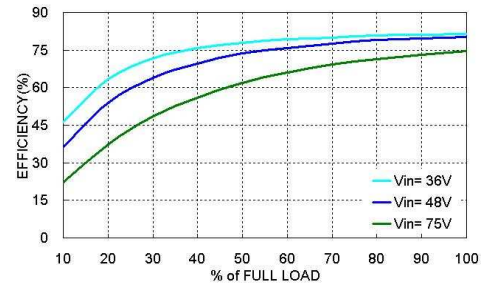

SDS(H)01-48S05 Efficiency vs. Output Current

**MECHANICAL DRAWING**

**SDS01**

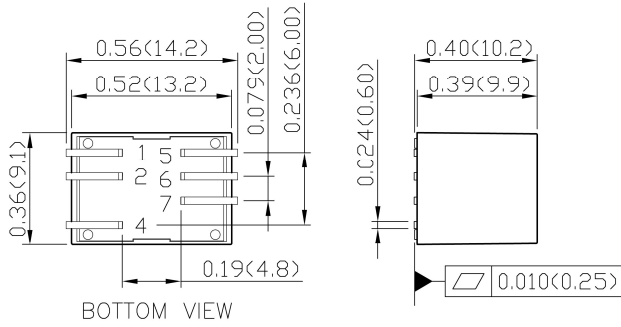

**PIN CONNECTION**

PIN	SINGLE	DUAL
1	+Vin	+Vin
2	-Vin	-Vin
4	Ctrl	Ctrl
5	NC	-Vout
6	-Vout	Common
7	+Vout	+Vout

1. All dimensions in inch (mm)
2. Tolerance :x.xx±0.02 (x.x±0.5)  
x.xxx±0.01 (x.xx±0.25)
3. Pin pitch tolerance ±0.01 (0.25)
4. Pin dimension tolerance ±0.004(0.1)

**SDH01**

