

Quarter Size Small Outline Package QSOP DIP Adapters

DIP ADAPTER MODULES ELIMINATE THE NEED TO REDESIGN MOTHERBOARDS OR MAY BE USED FOR BREADBOARD PROTOTYPING

DESCRIPTION

This new family of Accutek DIP Adapter Modules converts surface mount IC's to pin compatible DIP packages for creating drop-in replacements for end-of-life DIP IC's. Package types supported are: QSOP (Quarter Size Outline Package).

These DIP Adapters were developed for users with motherboard designs that require DIP's, now obsolete by manufacturers. These adapter modules save costly motherboard redesigns.

Available with machined contact pins. Accutek DIP Adapter Modules feature 6, 8, 14, 16, 18, 20, 22, 24 and 28 pins, are fully assembled and tested and may include a decoupling capacitor. These DIP Adapters can be manufactured turnkey or from customer supplied surface mount IC's. Modules range in length from 0.300" to 1.400" depending on number of pins and incorporate 0.300" and 0.600" row-to-row spacing with 0.100" lead spacing.

Custom configurations up to 200 pins, multi-chip and double sided modules are also available for special functions. A variety of pin lengths with varying diameters as well as custom sizes and spacing can be specified with different materials and finishes. All modules are designed in-house using PCB CAD workstations. Automated assembly and 100% testing are also performed in-house.

FEATURES

- Saves costly redesign of current motherboards
- Fully tested with lifetime limited warranty
- May include an on board decoupling capacitor
- IC assembly and testing available
- EPROM and Flash programming available
- Custom lead lengths available
- Custom multi-chip and double-sided modules available

ORDERING OPTIONS

- Adapter only
- Customer supplies chips - Accutek assembles on Accutek adapters, tests and delivers finished product in antistatic tubes.
- Complete turnkey - Accutek purchases IC's and passives. Then assembles, tests and delivers finished product in antistatic tubes.



5 NEW PASTURE ROAD
NEWBURYPORT, MA 01950-4040
PHONE: 978-465-6200 FAX: 978-462-3396
Email: sales@accutekmicro.com
Internet: www.accutekmicro.com

We can assemble your chips on to our adapter boards. Fully automated assembly and test at our Newburyport, Massachusetts facility.



No job to large or small.

AK06D300-QSOP

6 PIN QSOP TO DIP

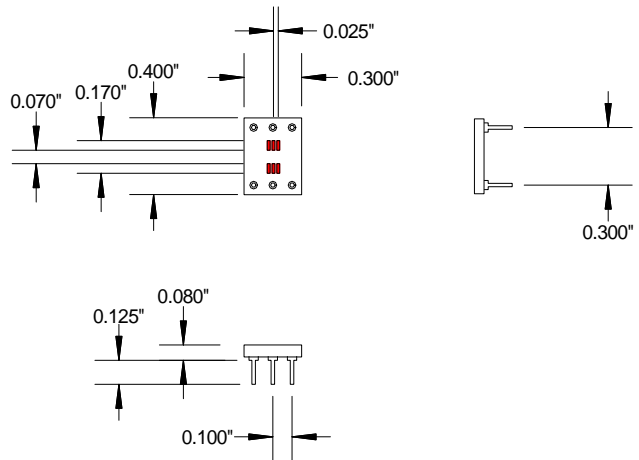

AK08D300-QSOP

8 PIN QSOP & SSOP TO DIP

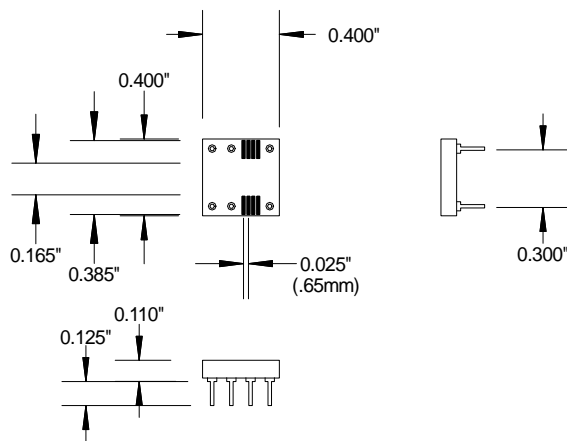

AK14D300-QSOP

14 PIN QSOP & SSOP TO DIP

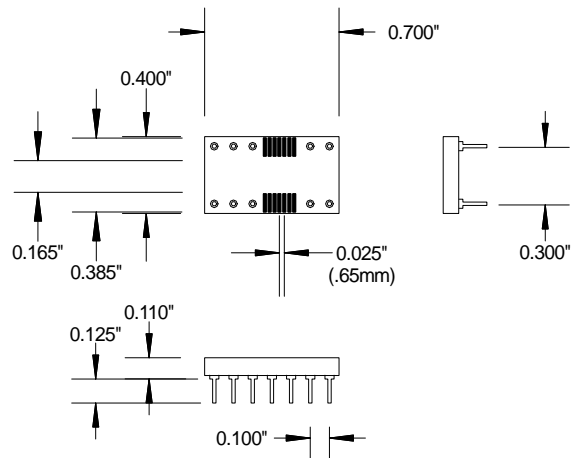

AK16D300-QSOP

16 PIN QSOP & SSOP TO DIP

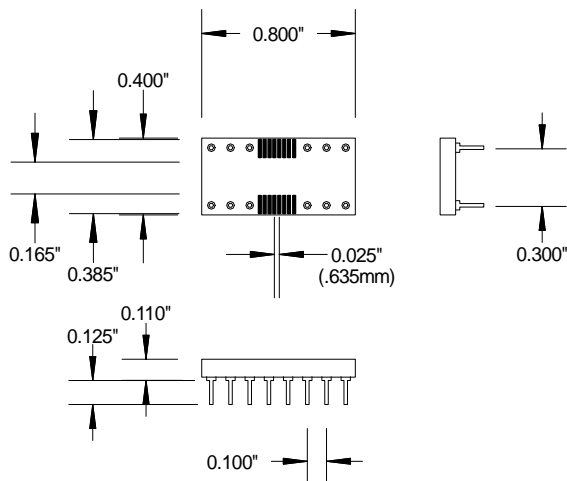

AK18D300-QSOP

18 PIN QSOP & SSOP TO DIP

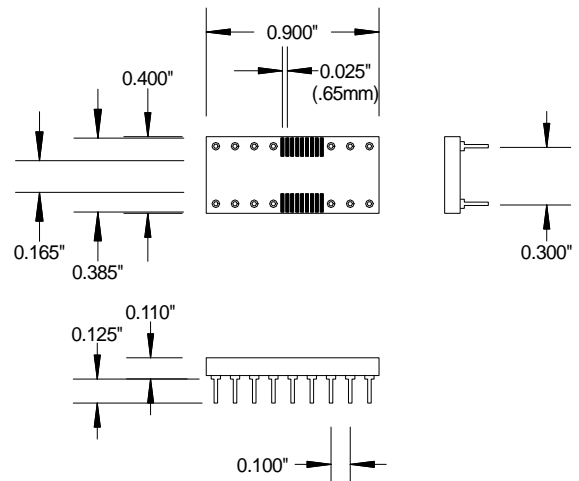

AK20D300-QSOP
20 PIN QSOP 0.025" PITCH TO DIP

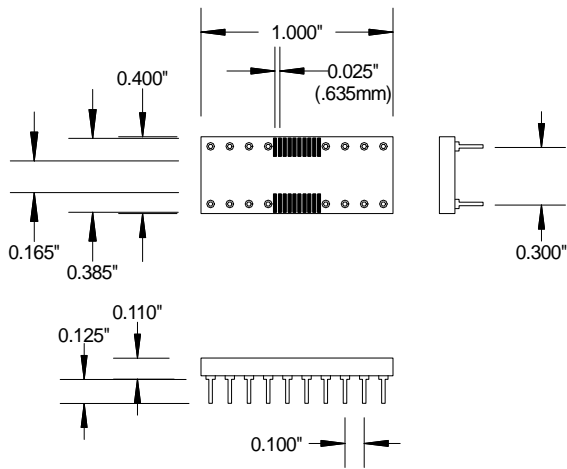

AK22D300-QSOP
22 PIN QSOP & SSOP TO DIP

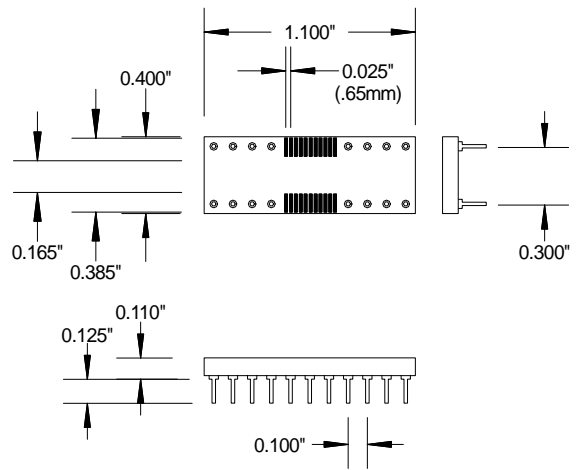

AK24D300-QSOP
24 PIN QSOP 0.025" PITCH TO DIP

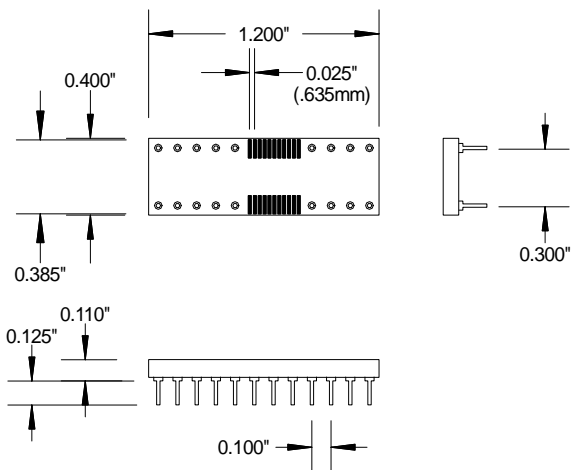

AK28D300-QSOP
28 PIN QSOP 0.025" PITCH TO DIP

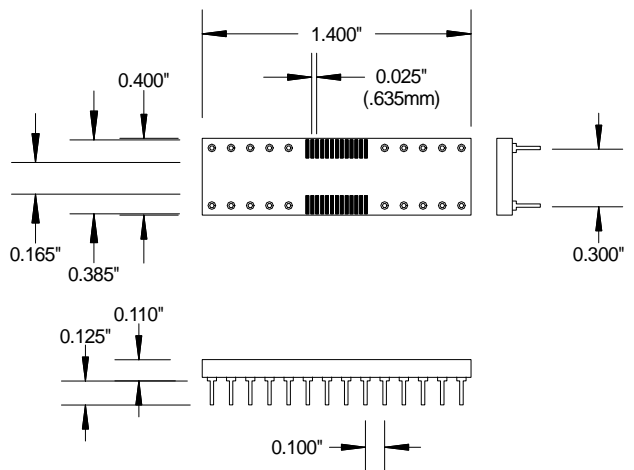

AK28D600-QSOP
28 PIN QSOP & SSOP TO DIP600

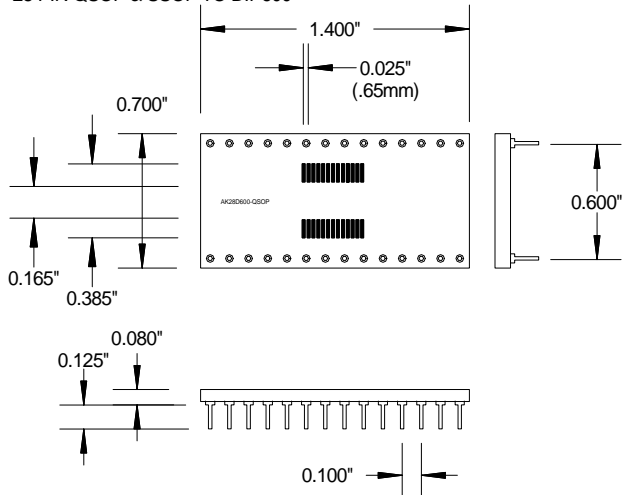

AK56D600-QSOP.025 PITCH
56 PIN QSOP 0.025 INCH PITCH TO 0.600" WIDE DIP

