

DATA SHEET

E38/8/25

Planar E cores and accessories

Supersedes data of September 2004

2008 Sep 01

CORES

Effective core parameters of a set of E cores

SYMBOL	PARAMETER	VALUE	UNIT
$\Sigma(l/A)$	core factor (C1)	0.272	mm ⁻¹
V_e	effective volume	10200	mm ³
l_e	effective length	52.4	mm
A_e	effective area	194	mm ²
A_{min}	minimum area	194	mm ²
m	mass of core half	≈ 25	g

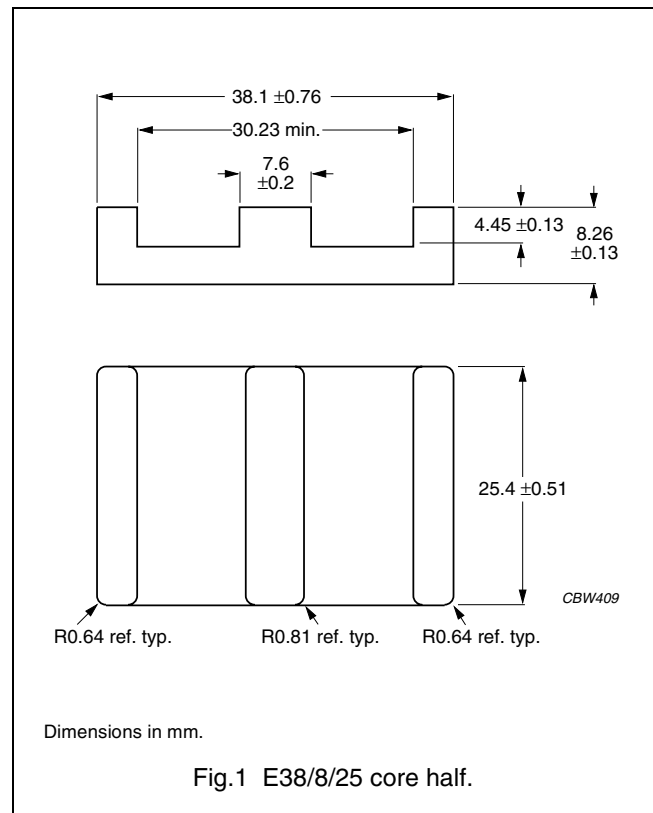

Effective core parameters of an E/PLT combination

SYMBOL	PARAMETER	VALUE	UNIT
$\Sigma(l/A)$	core factor (C1)	0.226	mm ⁻¹
V_e	effective volume	8460	mm ³
l_e	effective length	43.7	mm
A_e	effective area	194	mm ²
A_{min}	minimum area	194	mm ²
m	mass of plate	≈ 18	g

Ordering information for plates

GRADE	TYPE NUMBER
3C90	PLT38/25/3.8-3C90
3C92 <small>des</small>	PLT38/25/3.8-3C92
3C93 <small>des</small>	PLT38/25/3.8-3C93
3C94	PLT38/25/3.8-3C94
3C95 <small>des</small>	PLT38/25/3.8-3C95
3F3	PLT38/25/3.8-3F3
3F4 <small>des</small>	PLT38/25/3.8-3F4

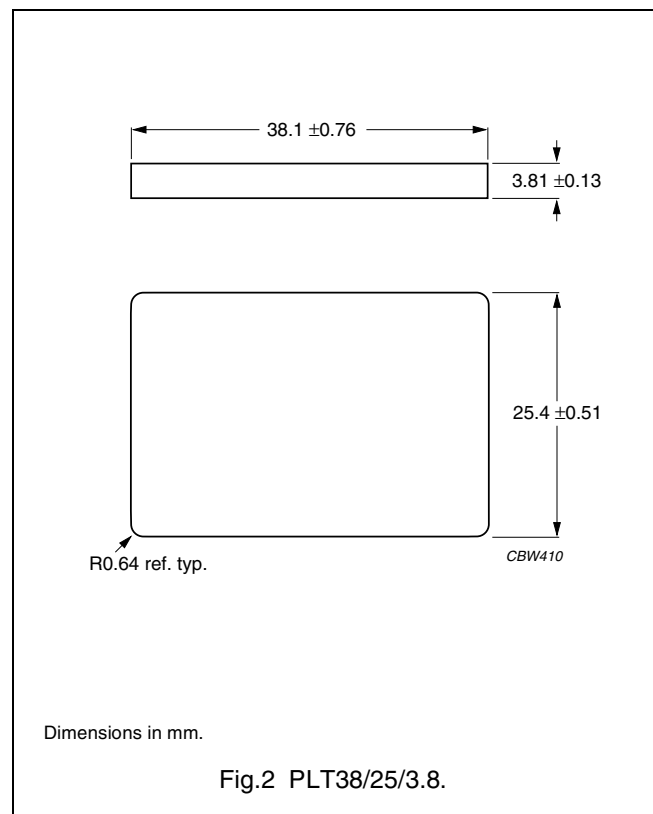

Planar E cores and accessories

E38/8/25

Core halves for use in combination with an E core

A_L measured in combination with a non-gapped core half, clamping force for A_L measurements, 40 ± 15 N, unless stated otherwise.

GRADE	A_L (nH)	μ_e	TOTAL AIR GAP (μm)	TYPE NUMBER
3C90	$250 \pm 3\%^{(1)}$	≈ 54	≈ 1100	E38/8/25-3C90-E250-E
	$315 \pm 3\%^{(1)}$	≈ 68	≈ 850	E38/8/25-3C90-E315-E
	$400 \pm 3\%^{(1)}$	≈ 86	≈ 650	E38/8/25-3C90-E400-E
	$630 \pm 5\%$	≈ 136	≈ 400	E38/8/25-3C90-A630-E
	$1000 \pm 10\%$	≈ 216	≈ 250	E38/8/25-3C90-A1000-E
	$7940 \pm 25\%$	≈ 1720	≈ 0	E38/8/25-3C90
3C92 <small>des</small>	$6100 \pm 25\%$	≈ 1320	≈ 0	E38/8/25-3C92
3C93 <small>des</small>	$7250 \pm 25\%$	≈ 1570	≈ 0	E38/8/25-3C93
3C94	$250 \pm 3\%^{(1)}$	≈ 54	≈ 1100	E38/8/25-3C94-E250-E
	$315 \pm 3\%^{(1)}$	≈ 68	≈ 850	E38/8/25-3C94-E315-E
	$400 \pm 3\%^{(1)}$	≈ 86	≈ 650	E38/8/25-3C94-E400-E
	$630 \pm 5\%$	≈ 136	≈ 400	E38/8/25-3C94-A630-E
	$1000 \pm 10\%$	≈ 216	≈ 250	E38/8/25-3C94-A1000-E
	$7940 \pm 25\%$	≈ 1720	≈ 0	E38/8/25-3C94
3C95 <small>des</small>	$9600 \pm 25\%$	≈ 2060	≈ 0	E38/8/25-3C95
3F3	$250 \pm 3\%^{(1)}$	≈ 54	≈ 1100	E38/8/25-3F3-E250-E
	$315 \pm 3\%^{(1)}$	≈ 68	≈ 850	E38/8/25-3F3-E315-E
	$400 \pm 3\%^{(1)}$	≈ 86	≈ 650	E38/8/25-3F3-E400-E
	$630 \pm 5\%$	≈ 136	≈ 400	E38/8/25-3F3-A630-E
	$1000 \pm 10\%$	≈ 216	≈ 250	E38/8/25-3F3-A1000-E
	$7250 \pm 25\%$	≈ 1570	≈ 0	E38/8/25-3F3
3F4 <small>des</small>	$250 \pm 3\%^{(1)}$	≈ 54	≈ 1100	E38/8/25-3F4-E250-E
	$315 \pm 3\%^{(1)}$	≈ 68	≈ 850	E38/8/25-3F4-E315-E
	$400 \pm 3\%^{(1)}$	≈ 86	≈ 650	E38/8/25-3F4-E400-E
	$630 \pm 5\%$	≈ 136	≈ 400	E38/8/25-3F4-A630-E
	$1000 \pm 10\%$	≈ 216	≈ 250	E38/8/25-3F4-A1000-E
	$3880 \pm 25\%$	≈ 840	≈ 0	E38/8/25-3F4

Note

1. Measured in combination with an equal gapped core half, clamping force for A_L measurements, 40 ± 15 N.

Planar E cores and accessories

E38/8/25

Core halves for use in combination with a plate (PLT)

A_L measured in combination with a plate (PLT), clamping force for A_L measurements, 40 ± 15 N.

GRADE	A_L (nH)	μ_e	AIR GAP (μm)	TYPE NUMBER
3C90	250 $\pm 3\%$	≈ 45	≈ 1100	E38/8/25-3C90-A250-P
	315 $\pm 3\%$	≈ 57	≈ 850	E38/8/25-3C90-A315-P
	400 $\pm 3\%$	≈ 72	≈ 650	E38/8/25-3C90-A400-P
	630 $\pm 5\%$	≈ 113	≈ 400	E38/8/25-3C90-A630-P
	1000 $\pm 10\%$	≈ 180	≈ 250	E38/8/25-3C90-A1000-P
	9250 $\pm 25\%$	≈ 1660	≈ 0	E38/8/25-3C90
3C92 <small>des</small>	7150 $\pm 25\%$	≈ 1290	≈ 0	E38/8/25-3C92
3C93 <small>des</small>	8500 $\pm 25\%$	≈ 1530	≈ 0	E38/8/25-3C93
3C94	250 $\pm 3\%$	≈ 45	≈ 1100	E38/8/25-3C94-A250-P
	315 $\pm 3\%$	≈ 57	≈ 850	E38/8/25-3C94-A315-P
	400 $\pm 3\%$	≈ 72	≈ 650	E38/8/25-3C94-A400-P
	630 $\pm 5\%$	≈ 113	≈ 400	E38/8/25-3C94-A630-P
	1000 $\pm 10\%$	≈ 180	≈ 250	E38/8/25-3C94-A1000-P
	9250 $\pm 25\%$	≈ 1660	≈ 0	E38/8/25-3C94
3C95 <small>des</small>	11200 $\pm 25\%$	≈ 1990	≈ 0	E38/8/25-3C95
3F3	250 $\pm 3\%$	≈ 45	≈ 1100	E38/8/25-3F3-A250-P
	315 $\pm 3\%$	≈ 57	≈ 850	E38/8/25-3F3-A315-P
	400 $\pm 3\%$	≈ 72	≈ 650	E38/8/25-3F3-A400-P
	630 $\pm 5\%$	≈ 113	≈ 400	E38/8/25-3F3-A630-P
	1000 $\pm 10\%$	≈ 180	≈ 250	E38/8/25-3F3-A1000-P
	8500 $\pm 25\%$	≈ 1520	≈ 0	E38/8/25-3F3
3F4 <small>des</small>	250 $\pm 3\%$	≈ 45	≈ 1100	E38/8/25-3F4-A250-P
	315 $\pm 3\%$	≈ 57	≈ 850	E38/8/25-3F4-A315-P
	400 $\pm 3\%$	≈ 72	≈ 650	E38/8/25-3F4-A400-P
	630 $\pm 5\%$	≈ 113	≈ 400	E38/8/25-3F4-A630-P
	1000 $\pm 10\%$	≈ 180	≈ 250	E38/8/25-3F4-A1000-P
	4600 $\pm 25\%$	≈ 830	≈ 0	E38/8/25-3F4

Properties of core sets under power conditions

GRADE	B (mT) at	CORE LOSS (W) at			
	H = 250 A/m; f = 10 kHz; T = 100 °C	f = 100 kHz; \hat{B} = 100 mT; T = 100 °C	f = 100 kHz; \hat{B} = 200 mT; T = 25 °C	f = 100 kHz; \hat{B} = 200 mT; T = 100 °C	f = 400 kHz; \hat{B} = 50 mT; T = 100 °C
E+E38-3C90	≥320	≤ 1.25	–	–	–
E+PLT38-3C90	≥320	≤ 1.05	–	–	–
E+E38-3C92	≥370	≤ 1.0	–	≤ 6.0	–
E+PLT38-3C92	≥370	≤ 0.85	–	≤ 5.0	–
E+E38-3C93	≥320	≤ 1.0 ⁽¹⁾	–	≤ 6.0 ⁽¹⁾	–
E+PLT38-3C93	≥320	≤ 0.85 ⁽¹⁾	–	≤ 5.0 ⁽¹⁾	–
E+E38-3C94	≥320	≤ 1.0	–	≤ 6.0	–
E+PLT38-3C94	≥320	≤ 0.85	–	≤ 5.0	–
E+E38-3C95	≥320	–	≤ 6.43	≤ 6.12	–
E+PLT38-3C95	≥320	–	≤ 5.0	≤ 4.74	–
E+E38-3F3	≥300	≤ 1.3	–	–	≤ 2.0
E+PLT38-3F3	≥300	≤ 1.1	–	–	≤ 1.65
E+E38-3F4	≥250	–	–	–	–
E+PLT38-3F4	≥250	–	–	–	–

1. Measured at 140 °C.

Properties of core sets under power conditions (continued)

GRADE	B (mT) at	CORE LOSS (W) at			
	H = 250 A/m; f = 10 kHz; T = 100 °C	f = 500 kHz; \hat{B} = 50 mT; T = 100 °C	f = 500 kHz; \hat{B} = 100 mT; T = 100 °C	f = 1 MHz; \hat{B} = 30 mT; T = 100 °C	f = 3 MHz; \hat{B} = 10 mT; T = 100 °C
E+E38-3F4	≥250	–	–	≤ 3.0	≤ 5.0
E+PLT38-3F4	≥250	–	–	≤ 2.5	≤ 4.0



DATA SHEET STATUS DEFINITIONS

DATA SHEET STATUS	PRODUCT STATUS	DEFINITIONS
Preliminary specification	Development	This data sheet contains preliminary data. Ferroxcube reserves the right to make changes at any time without notice in order to improve design and supply the best possible product.
Product specification	Production	This data sheet contains final specifications. Ferroxcube reserves the right to make changes at any time without notice in order to improve design and supply the best possible product.

DISCLAIMER

Life support applications — These products are not designed for use in life support appliances, devices, or systems where malfunction of these products can reasonably be expected to result in personal injury. Ferroxcube customers using or selling these products for use in such applications do so at their own risk and agree to fully indemnify Ferroxcube for any damages resulting from such application.

PRODUCT STATUS DEFINITIONS

STATUS	INDICATION	DEFINITION
Prototype		These are products that have been made as development samples for the purposes of technical evaluation only. The data for these types is provisional and is subject to change.
Design-in		These products are recommended for new designs.
Preferred		These products are recommended for use in current designs and are available via our sales channels.
Support		These products are not recommended for new designs and may not be available through all of our sales channels. Customers are advised to check for availability.