



YOUR CHOICE OUR COMMITMENT™

MNE Stepper Motors

STEPPERS



**PRODUCT
CATALOG**

3 | Stepper Motor Overview

Size 16 Model HY 200 16074
 Size 17 Model HY 200 1713.....5
 Size 17 Model HY 200 1716
 Size 17 Model HY 200 17187
 Size 17 High Performance Model HS 200 17148
 Size 17 High Performance Model HS 200 17169
 Size 17 High Performance Model HS 200 1720.....10
 Size 23 Model HY 200 2215.....11
 Size 23 Model HY 200 2220.....12
 Size 23 Model HY 200 222613
 Size 23 High Performance Model HS 200 221614
 Size 23 High Performance Model HS 200 222115
 Size 23 High Performance Model HS 200 223116
 Size 23 High Performance Model HT 200 2220.....17
 Size 34 Model HN 200 342618
 Size 34 Model HN 200 343819
 Size 34 Model HN 200 345120
 Size 34 High Performance Model HS 200 343721
 Size 34 High Performance Model HS 200 3448.....22
 Size 34 High Performance Model HS 200 3455.....23
 Size 42 Model HY 200 427024
 Size 42 Model HY 200 427025

26 | Customizations / Options Size 23

27 | Customizations / Options Size 23

28 | Customizations / Options Size 34

29 | Customizations / Options Size 34

30 | Connection Diagrams

31 | Step Sequence

CATALOG PART NUMBER DESCRIPTION

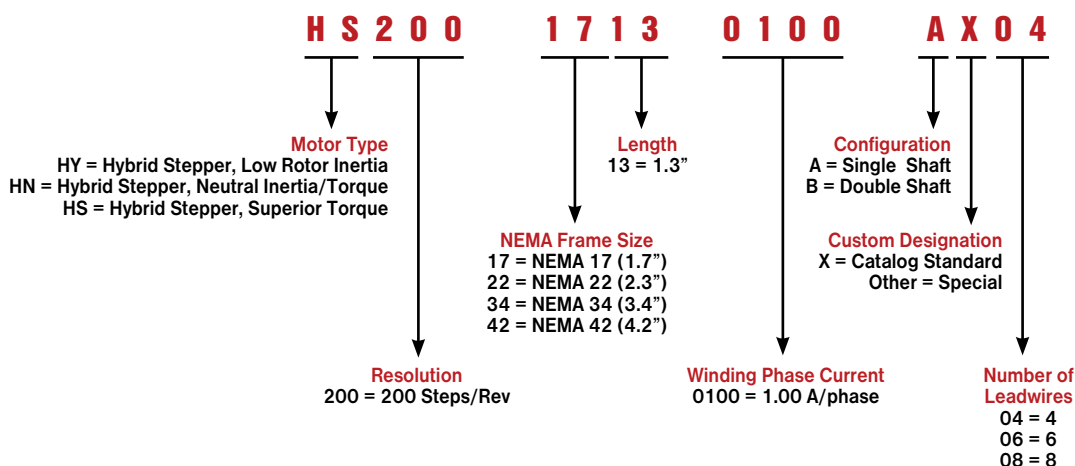

MAE® Stepper Motors



AMETEK® Stepper Motors
EUROPE

offers a wide range of MAE brand stepper motor solutions. The HY series hybrid stepper motors feature low rotor inertia for maximum possible acceleration. The HN series hybrid stepper motors offer a calculated balance between low rotor inertia and high torque. The HS series hybrid stepper motors are optimized for superior torque characteristics. Additionally, both the HN and HS series feature low detent torque to holding torque ratios to provide smooth operation as well as the fine positioning capability required for microstep operation.

Motors may be customized with value added features including but not limited to: gearboxes, encoders, shaft details, leadwire-connector assemblies, and more.

All specifications shown are typical at 20 °C unless otherwise noted.

Shaft extensions

All motors can be supplied with single or double ended shaft.

Rotation

The motor rotation can run clockwise or counterclockwise, depending on the commutation.

Operating temperature

Ambient operating temperature -20 °C to +40 °C.

Number of leads

Refer to specifications of individual models for standard lead wire configuration. Motors can be supplied with 4, 6 or 8 leads upon request; however, rated current and torque may be reduced.

Angular accuracy

Standard angular accuracy is ±5 %. Angular accuracy is defined as the deviation from a theoretical position, in percentage of one step, after any number of steps.

Holding torque

The typical values of holding torque of the different models are indicated in the data charts. Holding torque is measured with two phases each supplied at the rated current.

Specifications and approvals

Motors are manufactured according to EN 60034-1:1995-02. Motors with drive voltage higher than or equal to 120 V are suitable to be fitted on machines equipped with additional insulation or when the motor itself has the grounding through its clamping screws. Due to thermal considerations, stepper motors cannot always be operated continuously in dynamic conditions at the level of their static rated phased current.

Stepper Motors

- Accurate open loop control for high performance positioning applications
- Excellent low speed torque
- Simple, rugged construction for high reliability and long service life
- Smooth, quiet operation
- Standard NEMA frame sizes
- Precision honed stators and ground rotors for tight air gap and maximum performance
- CE approved

SIZE 16 STEPPER MOTOR DATA

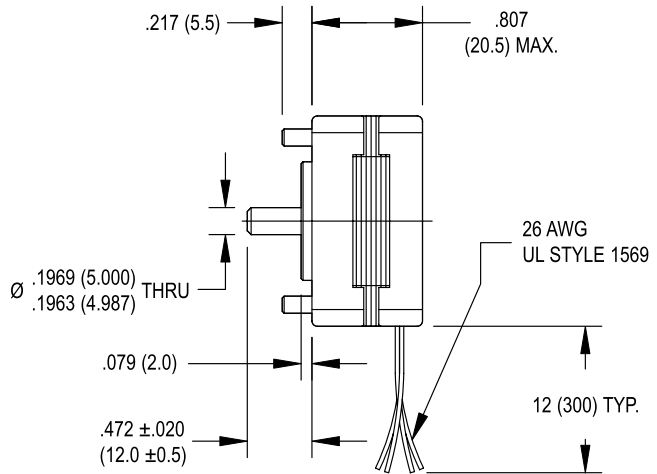
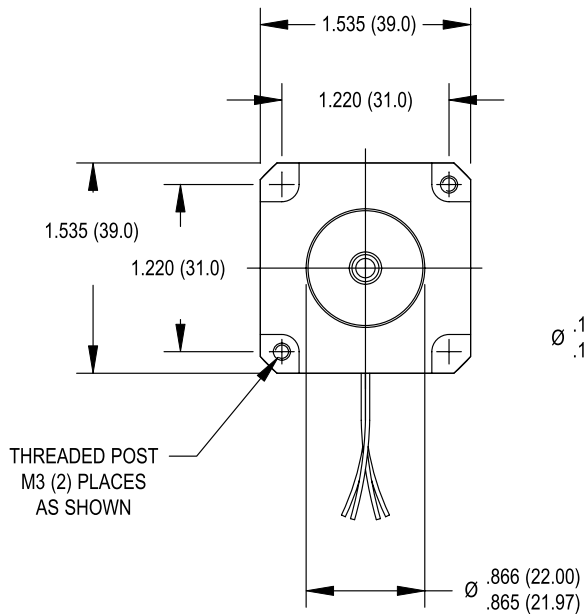

| Specification | Units | HY 200 1607 | |
|-------------------------|--|--------------|--|
| | | 0060 | |
| Rated Phase Current | A | 0.60 | |
| Phase Resistance | Ω | 6.6 | |
| Phase Inductance | mH | 8.5 | |
| Holding Torque Unipolar | oz-in Ncm | — | |
| Holding Torque Bipolar | oz-in Ncm | 12 8.7 | |
| Detent Torque | oz-in Ncm | 1.4 1.0 | |
| Rotor Inertia | oz-in-s ² $\times 10^{-4}$ g-cm ² | 1.6 11 | |
| Motor Weight (Mass) | lb kg | 0.33 0.15 | |
| Maximum Voltage | V | 40 | |
| Std. No. of Leads | — | 4 | |

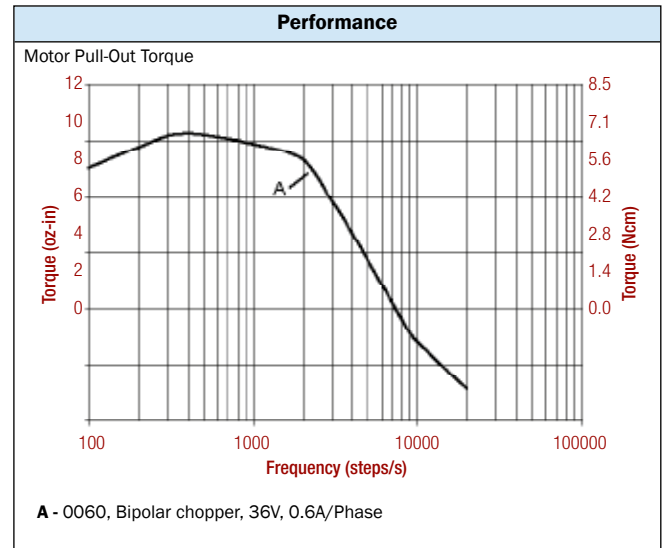

- Standard Features**
- Step angle: 1.8°
 - Step angle accuracy: 5%
 - Insulation class: B (130°C)
 - NEMA 17 mounting configuration
 - Neodymium magnets
 - Additional windings and customization options available

- Complementary Products**
- Gearboxes
 - Encoders

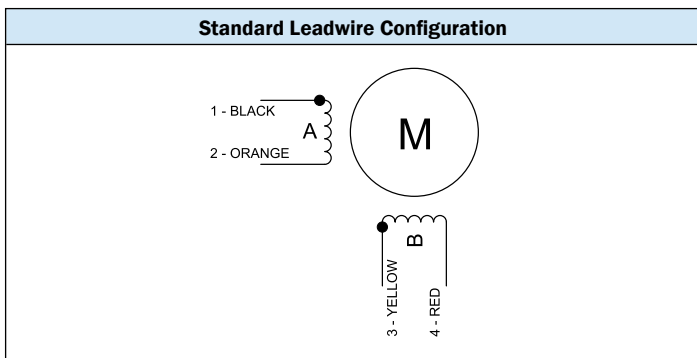

SIZE 17 STEPPER MOTOR DATA

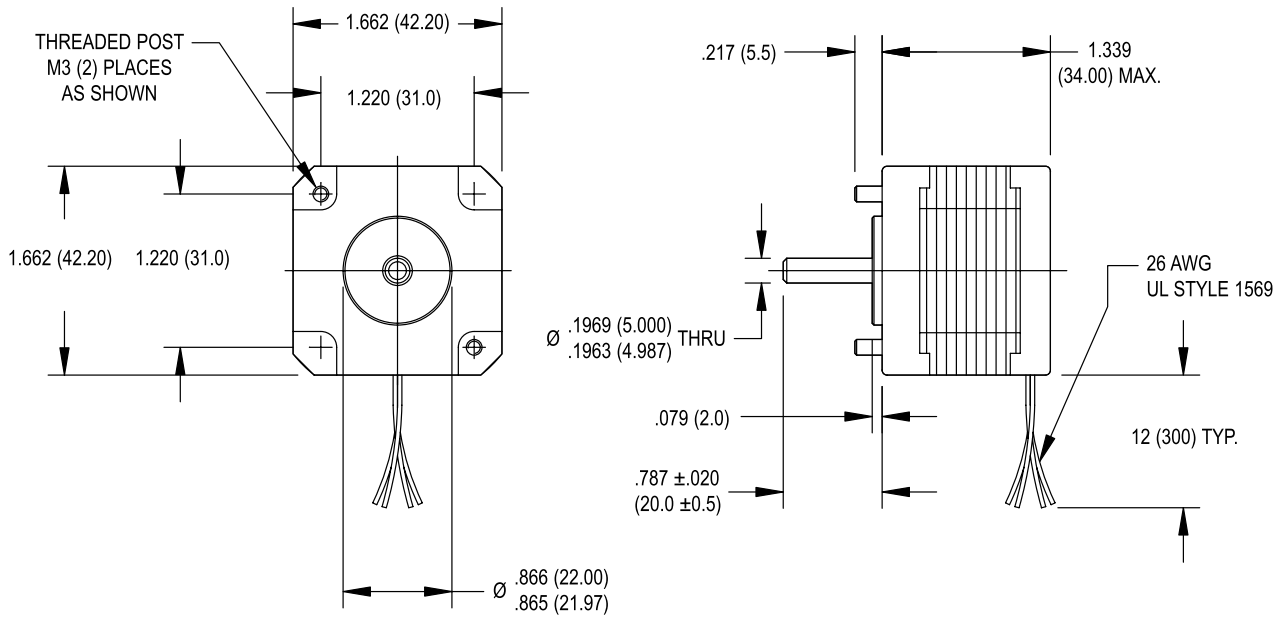

| Specification | Units | HY 200 1713 | |
|-------------------------|--|-------------|------|
| | | 0033 | 0150 |
| Rated Phase Current | A | 0.33 | 1.50 |
| Phase Resistance | Ω | 23.9 | 1.0 |
| Phase Inductance | mH | 28.9 | 1.2 |
| Holding Torque Unipolar | oz-in | — | — |
| | Ncm | — | — |
| Holding Torque Bipolar | oz-in | 19.4 | 18.4 |
| | Ncm | 13.7 | 13.0 |
| Detent Torque | oz-in | 2.4 | 2.4 |
| | Ncm | 1.7 | 1.7 |
| Rotor Inertia | oz-in-s ² x10 ⁻⁴ | 2.5 | 2.5 |
| | g-cm ² | 18 | 18 |
| Motor Weight (Mass) | lb | 0.4 | 0.4 |
| | kg | 0.2 | 0.2 |
| Maximum Voltage | V | 40 | 40 |
| Std. No. of Leads | — | 4 | 4 |

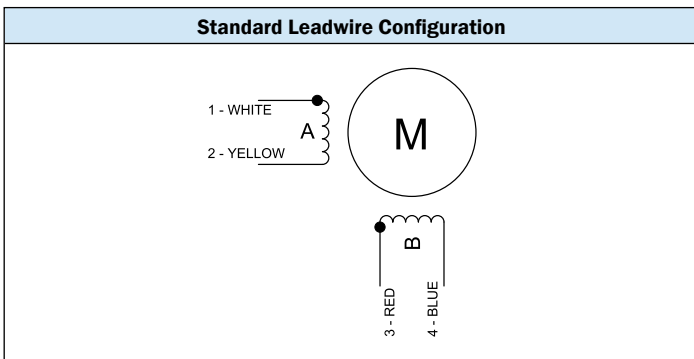
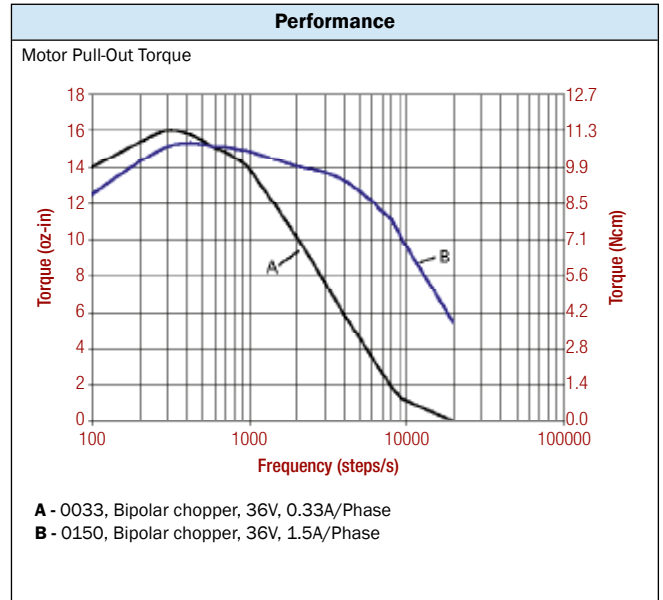

- ### Standard Features
- Step angle: 1.8°
 - Step angle accuracy: 5%
 - Insulation class: B (130 °C)
 - NEMA 17 mounting configuration
 - Neodymium magnets
 - Additional windings and customization options available

- ### Complementary Products
- Gearboxes
 - Encoders

SIZE 17 STEPPER MOTOR DATA

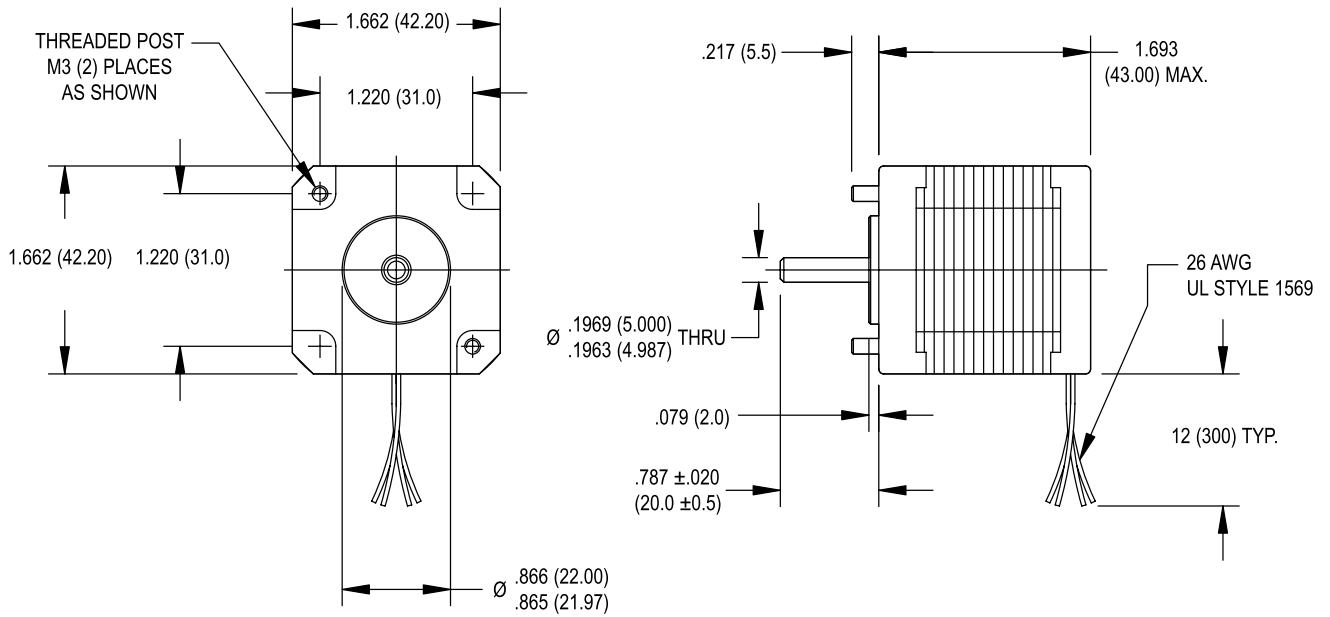

| Specification | Units | HY 200 1717 | |
|-------------------------|--|--------------|--|
| | | 0100 | |
| Rated Phase Current | A | 1.00 | |
| Phase Resistance | Ω | 4.6 | |
| Phase Inductance | mH | 10.6 | |
| Holding Torque Unipolar | oz-in Ncm | - | |
| Holding Torque Bipolar | oz-in Ncm | 32.7 23.1 | |
| Detent Torque | oz-in Ncm | 2.4 1.7 | |
| Rotor Inertia | oz-in-s ² $\times 10^{-4}$ g-cm ² | 4.5 32 | |
| Motor Weight (Mass) | lb kg | 0.7 0.3 | |
| Maximum Voltage | V | 40 | |
| Std. No. of Leads | - | 4 | |

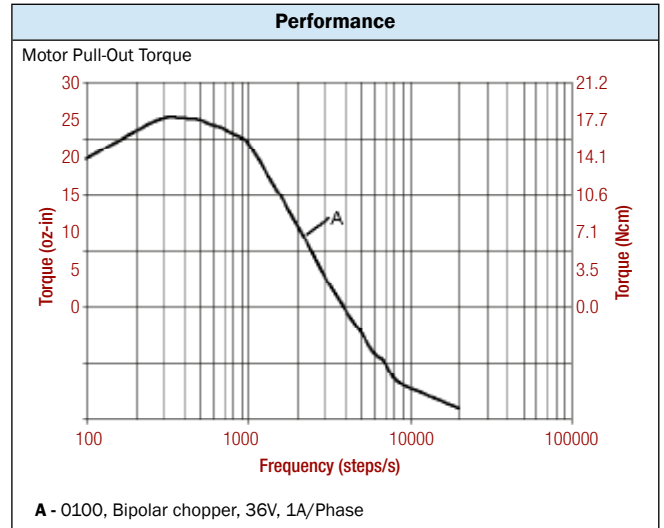

- ### Standard Features
- Step angle: 1.8°
 - Step angle accuracy: 5%
 - Insulation class: B (130°C)
 - NEMA 17 mounting configuration
 - Neodymium magnets
 - Additional windings and customization options available

- ### Complementary Products
- Gearboxes
 - Encoders

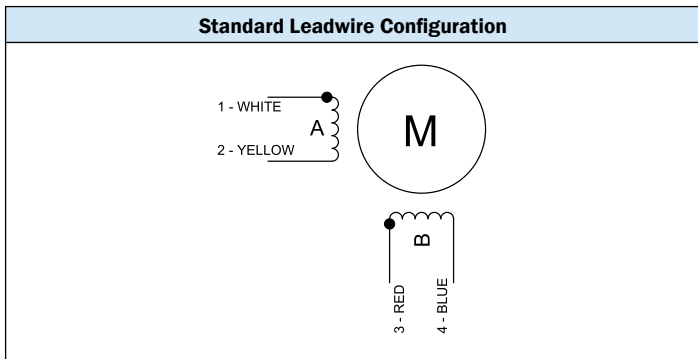

SIZE 17 STEPPER MOTOR DATA

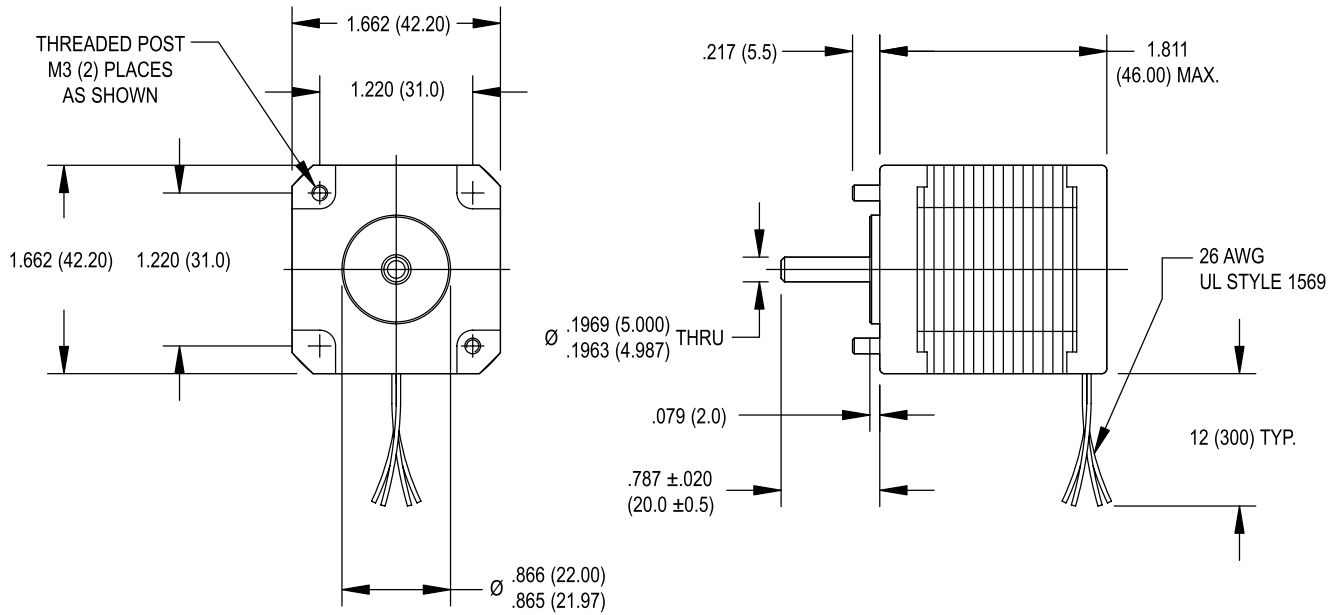

| Specification | Units | HY 200 1718 | |
|-------------------------|---|--------------|--------------|
| | | 0090 | 0230 |
| Rated Phase Current | A | 0.90 | 2.30 |
| Phase Resistance | Ω | 4.2 | 0.72 |
| Phase Inductance | mH | 5.8 | 0.83 |
| Holding Torque Unipolar | oz-in Ncm | — | — |
| Holding Torque Bipolar | oz-in Ncm | 41.1 29.0 | 41.1 29.0 |
| Detent Torque | oz-in Ncm | 6.4 4.5 | 6.4 4.5 |
| Rotor Inertia | oz-in-s ² ×10 ⁻⁴ g-cm ² | 5.1 36 | 5.1 36 |
| Motor Weight (Mass) | lb kg | 0.7 0.3 | 0.7 0.3 |
| Maximum Voltage | V | 40 | 40 |
| Std. No. of Leads | — | 4 | 4 |

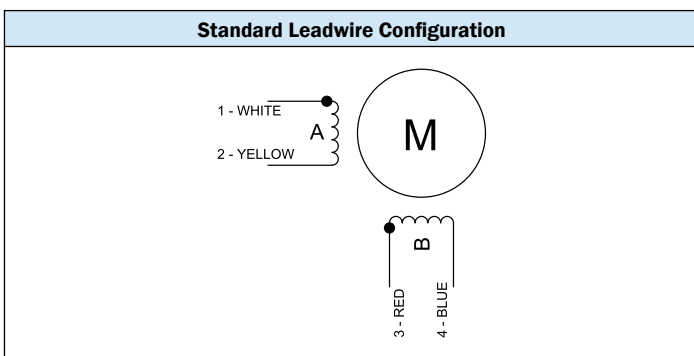
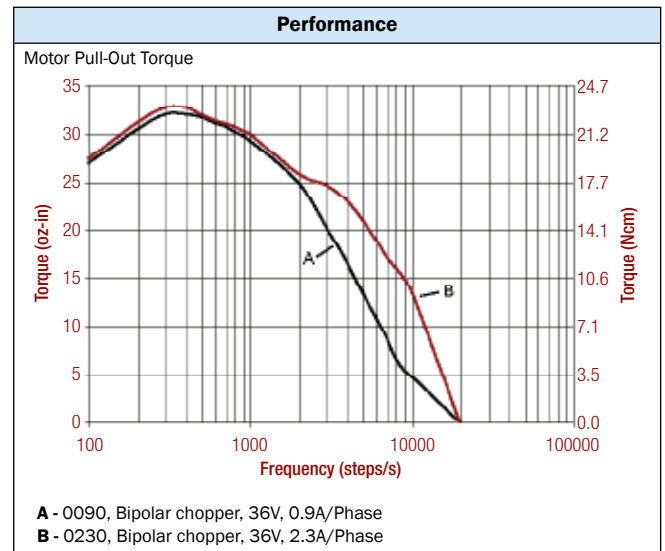

- Standard Features**
- Step angle: 1.8°
 - Step angle accuracy: 5%
 - Insulation class: B (130 °C)
 - NEMA 17 mounting configuration
 - Neodymium magnets
 - Additional windings and customization options available

- Complementary Products**
- Gearboxes
 - Encoders

SIZE 17 HIGH PERFORMANCE STEPPER MOTOR DATA

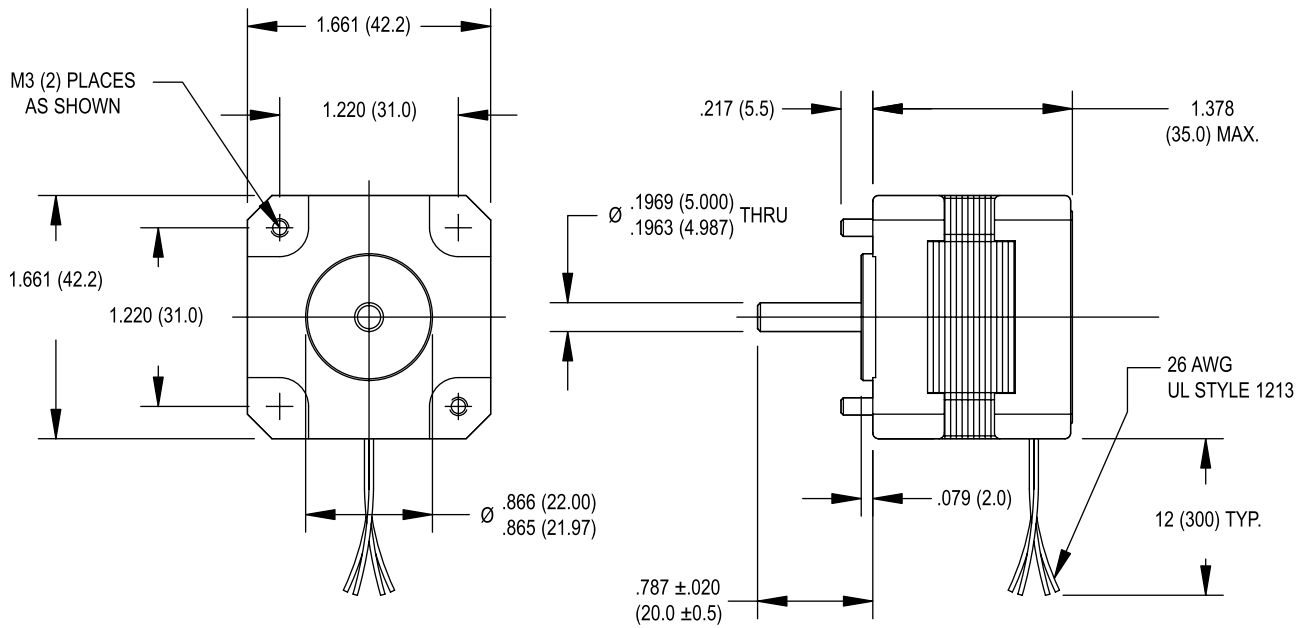

| Specification | Units | HS 200 1714 | | |
|-------------------------|--|--------------|--------------|--------------|
| | | 0033 | 0100 | 0150 |
| Rated Phase Current | A | 0.33 | 1.00 | 1.50 |
| Phase Resistance | Ω | 26.5 | 2.95 | 1.25 |
| Phase Inductance | mH | 38.8 | 4.45 | 1.80 |
| Holding Torque Unipolar | oz-in Ncm | — | — | — |
| Holding Torque Bipolar | oz-in Ncm | 37 26 | 37 26 | 37 26 |
| Detent Torque | oz-in Ncm | 2.3 1.6 | 2.3 1.6 | 2.3 1.6 |
| Rotor Inertia | oz-in-s ² $\times 10^{-4}$ g-cm ² | 6.4 45 | 6.4 45 | 6.4 45 |
| Motor Weight (Mass) | lb kg | 0.51 0.23 | 0.51 0.23 | 0.51 0.23 |
| Maximum Voltage | V | 40 | 40 | 40 |
| Std. No. of Leads | — | 4 | 4 | 4 |

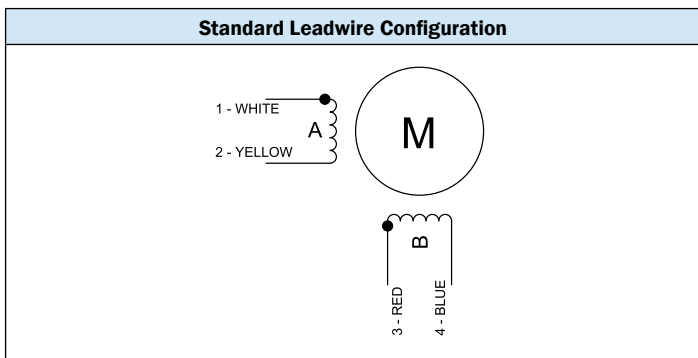
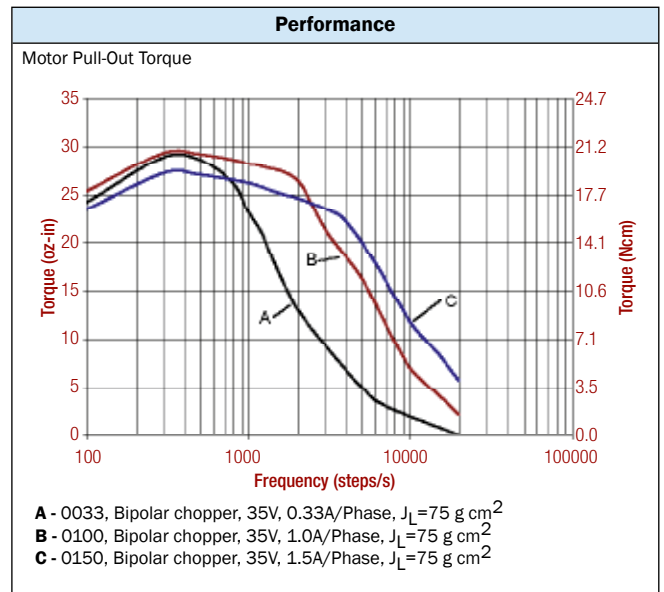

- ### Standard Features
- Step angle: 1.8°
 - Step angle accuracy: 5%
 - Insulation class: B (130°C)
 - Optimized for microstep operation
 - NEMA 17 mounting configuration
 - Neodymium magnets
 - Additional windings and customization options available
 - CE approval pending

- ### Complementary Products
- Gearboxes
 - Encoders

SIZE 17 HIGH PERFORMANCE STEPPER MOTOR DATA

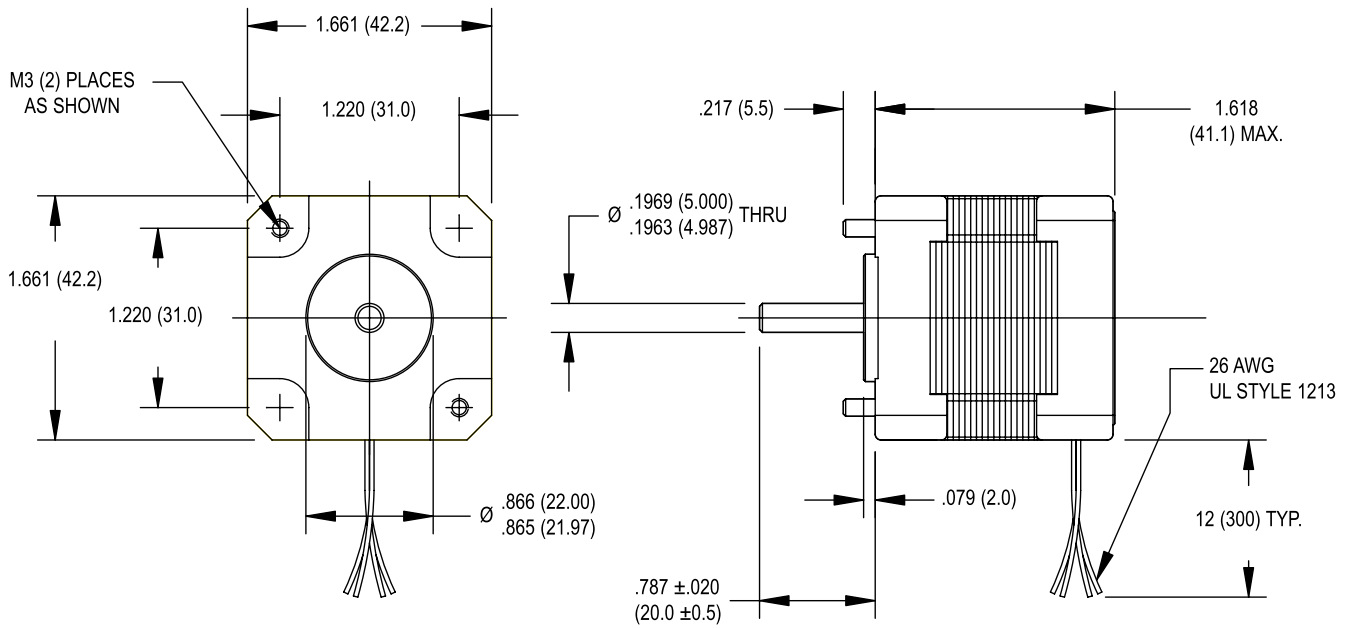

| Specification | Units | HS 200 1716 | | |
|-------------------------|--|-------------|------|------|
| | | 0033 | 0100 | 0150 |
| Rated Phase Current | A | 0.33 | 1.00 | 1.50 |
| Phase Resistance | Ω | 27.2 | 2.86 | 1.40 |
| Phase Inductance | mH | 66.7 | 6.74 | 3.25 |
| Holding Torque Unipolar | oz-in | — | — | — |
| | Ncm | — | — | — |
| Holding Torque Bipolar | oz-in | 47 | 47 | 47 |
| | Ncm | 33 | 33 | 33 |
| Detent Torque | oz-in | 2.3 | 2.3 | 2.3 |
| | Ncm | 1.6 | 1.6 | 1.6 |
| Rotor Inertia | oz-in-s ² x10 ⁻⁴ | 9.3 | 9.3 | 9.3 |
| | g-cm ² | 66 | 66 | 66 |
| Motor Weight (Mass) | lb | 0.66 | 0.66 | 0.66 |
| | kg | 0.30 | 0.30 | 0.30 |
| Maximum Voltage | V | 40 | 40 | 40 |
| Std. No. of Leads | — | 4 | 4 | 4 |

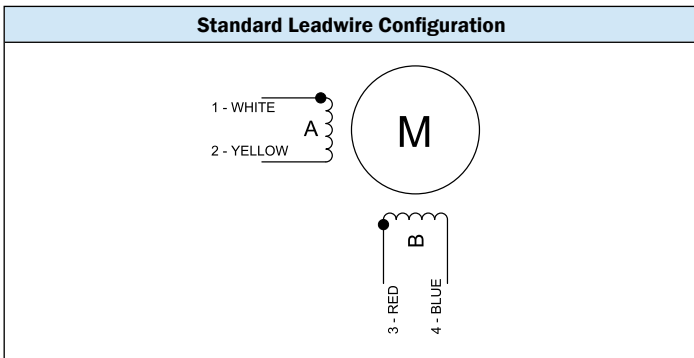
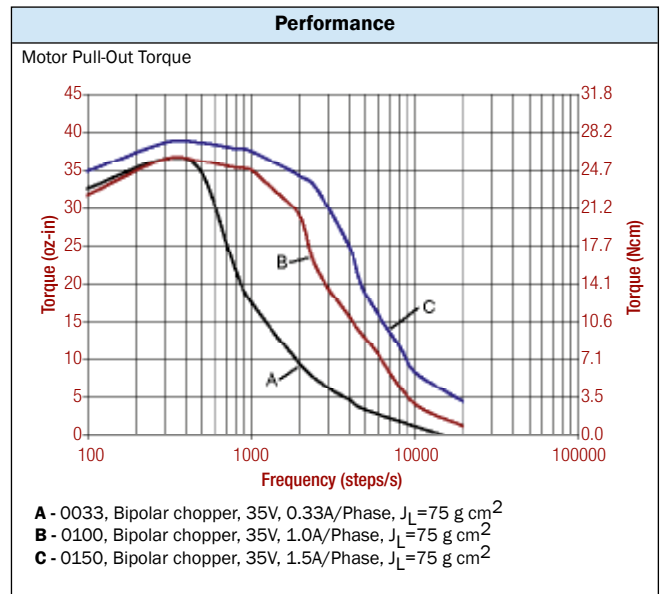

- Standard Features**
- Step angle: 1.8°
 - Step angle accuracy: 5%
 - Insulation class: B (130 °C)
 - Optimized for microstep operation
 - NEMA 17 mounting configuration
 - Neodymium magnets
 - Additional windings and customization options available
 - CE approval pending

- Complementary Products**
- Gearboxes
 - Encoders

SIZE 17 HIGH PERFORMANCE STEPPER MOTOR DATA

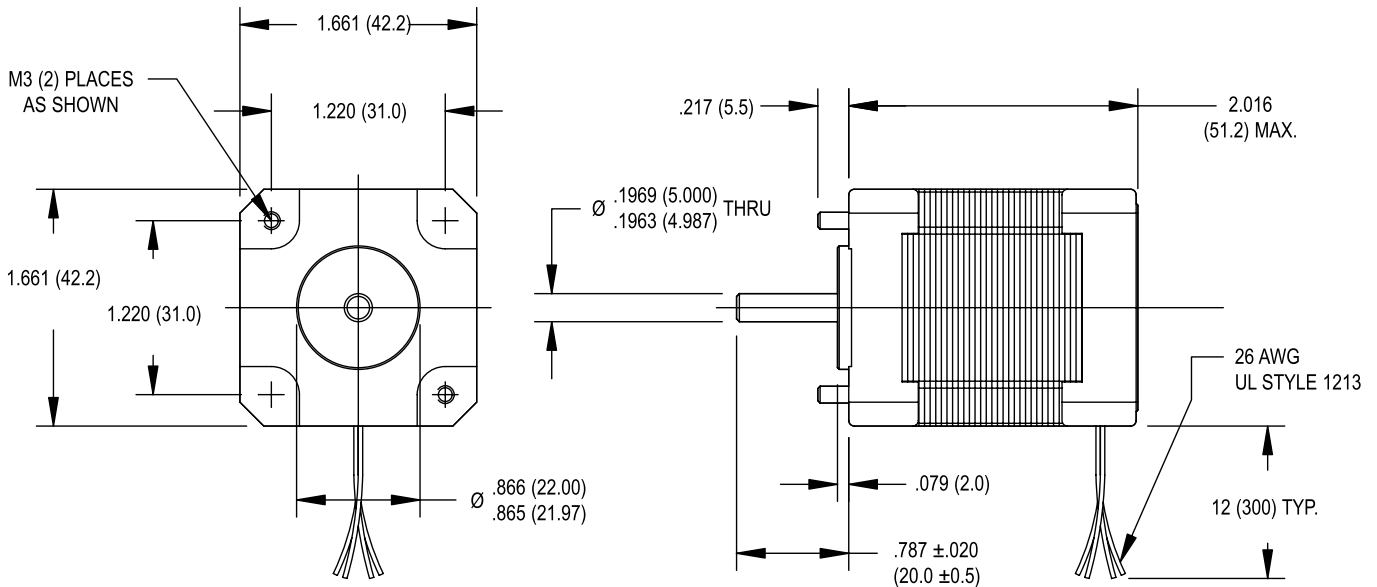

| Specification | Units | HS 200 1720 | | |
|-------------------------|--|--------------|--------------|--------------|
| | | 0033 | 0100 | 0150 |
| Rated Phase Current | A | 0.33 | 1.00 | 1.50 |
| Phase Resistance | Ω | 28.0 | 3.00 | 1.45 |
| Phase Inductance | mH | 50.0 | 5.50 | 2.90 |
| Holding Torque Unipolar | oz-in Ncm | — | — | — |
| Holding Torque Bipolar | oz-in Ncm | 71 50 | 71 50 | 71 50 |
| Detent Torque | oz-in Ncm | 3.5 2.5 | 3.5 2.5 | 3.5 2.5 |
| Rotor Inertia | oz-in-s ² $\times 10^{-4}$ g-cm ² | 12.7 90 | 12.7 90 | 12.7 90 |
| Motor Weight (Mass) | lb kg | 0.84 0.38 | 0.84 0.38 | 0.84 0.38 |
| Maximum Voltage | V | 40 | 40 | 40 |
| Std. No. of Leads | — | 4 | 4 | 4 |

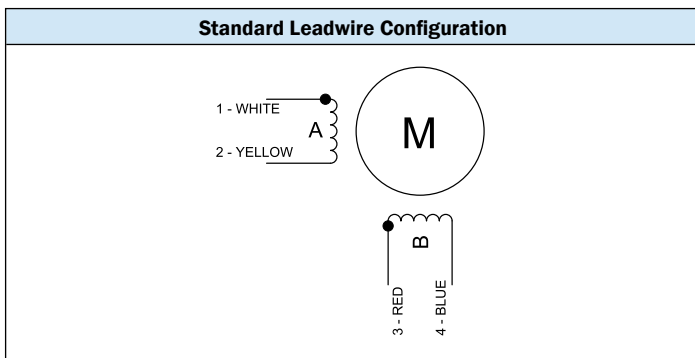
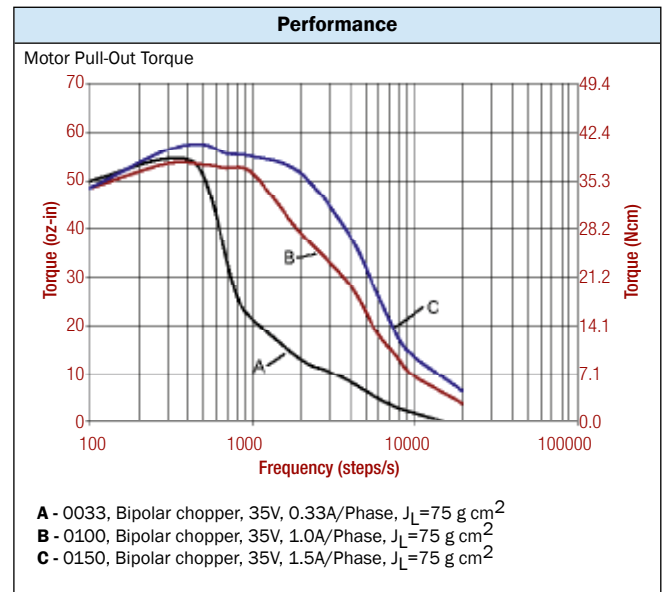

- ### Standard Features
- Step angle: 1.8°
 - Step angle accuracy: 5%
 - Insulation class: B (130°C)
 - Optimized for microstep operation
 - NEMA 17 mounting configuration
 - Neodymium magnets
 - Additional windings and customization options available
 - CE approval pending

- ### Complementary Products
- Gearboxes
 - Encoders

SIZE 23 STEPPER MOTOR DATA

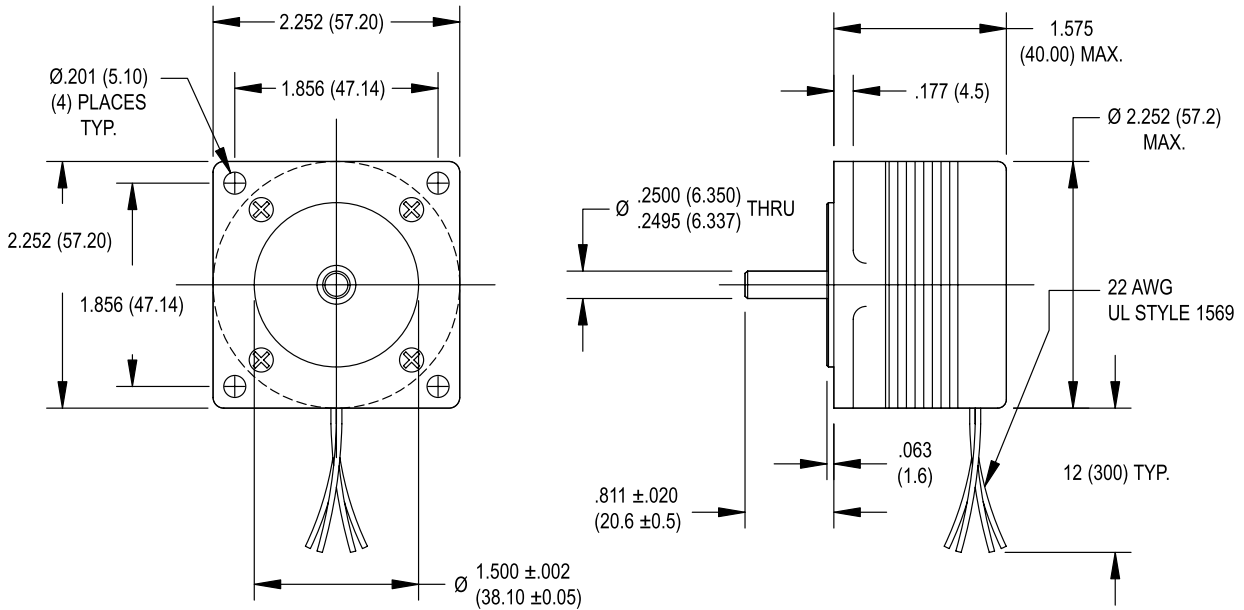

| Specification | Units | HY 200 2215 | | | |
|-------------------------|---|--------------|--------------|--------------|--------------|
| | | 0033 | 0100 | 0150 | 0220 |
| Rated Phase Current | A | 0.33 | 1.00 | 1.50 | 2.20 |
| Phase Resistance | Ω | 33.8 | 3.4 | 1.5 | 0.7 |
| Phase Inductance | mH | 54.6 | 3.8 | 1.5 | 1.2 |
| Holding Torque Unipolar | oz-in Ncm | — | 38 | 35 | — |
| Holding Torque Bipolar | oz-in Ncm | 45 32 | 48 34 | 47 33 | 44 31 |
| Detent Torque | oz-in Ncm | 4.8 3.4 | 4.8 3.4 | 4.8 3.4 | 4.8 3.4 |
| Rotor Inertia | oz-in-s ² x10 ⁻⁴ g-cm ² | 7.9 56 | 7.9 56 | 7.9 56 | 7.9 56 |
| Motor Weight (Mass) | lb kg | 0.75 0.34 | 0.75 0.34 | 0.75 0.34 | 0.75 0.34 |
| Maximum Voltage | V | 75 | 75 | 75 | 75 |
| Std. No. of Leads | — | 4 | 8 | 8 | 4 |

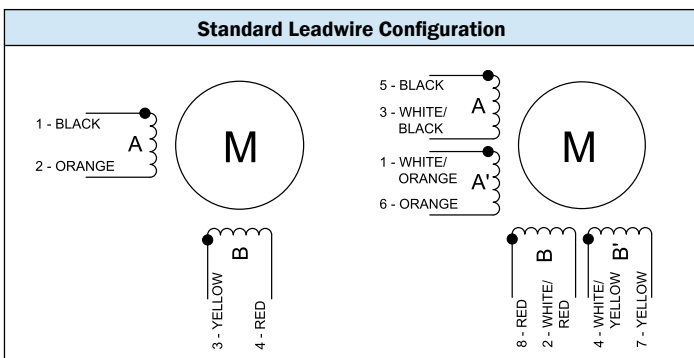
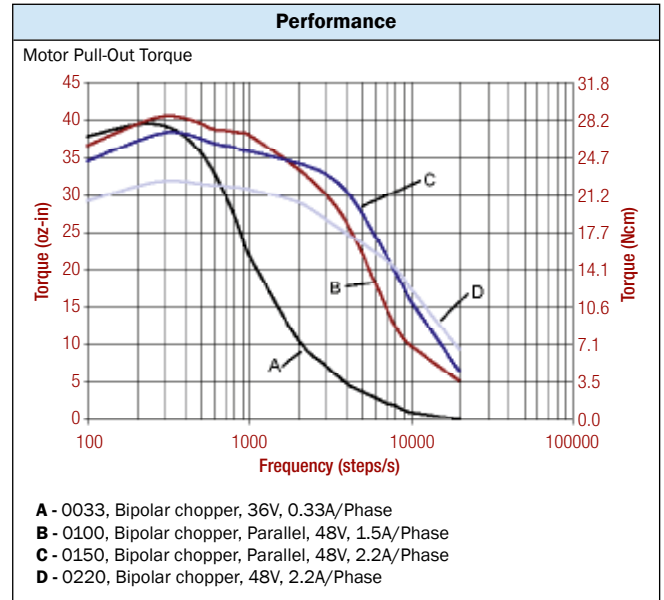

- ### Standard Features
- Step angle: 1.8°
 - Step angle accuracy: 5%
 - Insulation class: B (130 °C)
 - NEMA 23 mounting configuration
 - AlNiCo magnets
 - Additional windings and customization options available
 - CE approved

- ### Complementary Products
- Gearboxes
 - Encoders

SIZE 23 STEPPER MOTOR DATA

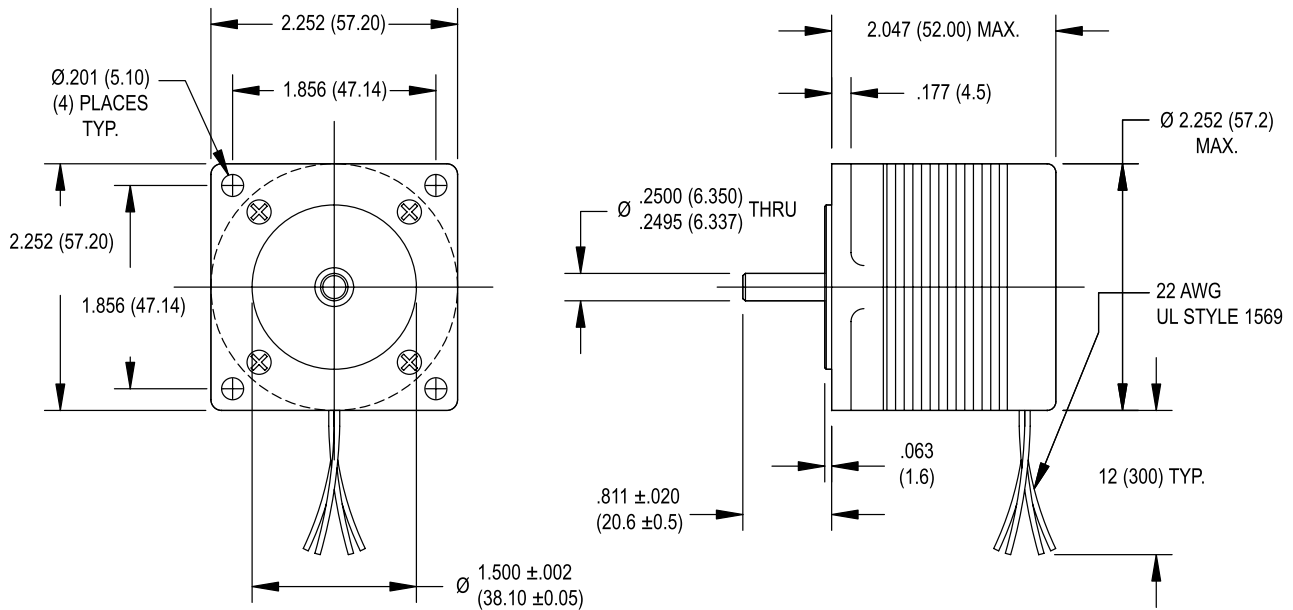

| Specification | Units | HY 200 2220 | | |
|-------------------------|--|-------------|------|------|
| | | 0044 | 0100 | 0210 |
| Rated Phase Current | A | 0.44 | 1.00 | 2.10 |
| Phase Resistance | Ω | 23.0 | 5.0 | 1.1 |
| Phase Inductance | mH | 39.2 | 8.0 | 1.7 |
| Holding Torque Unipolar | oz-in | 74 | 75 | 74 |
| | Ncm | 52 | 53 | 52 |
| Holding Torque Bipolar | oz-in | 92 | 98 | 91 |
| | Ncm | 65 | 69 | 64 |
| Detent Torque | oz-in | 7.5 | 7.5 | 7.5 |
| | Ncm | 5.3 | 5.3 | 5.3 |
| Rotor Inertia | oz-in-s ² x10 ⁻⁴ | 17.6 | 17.6 | 17.6 |
| | g-cm ² | 124 | 124 | 124 |
| Motor Weight (Mass) | lb | 1.1 | 1.1 | 1.1 |
| | kg | 0.50 | 0.50 | 0.50 |
| Maximum Voltage | V | 75 | 75 | 75 |
| Std. No. of Leads | - | 8 | 8 | 8 |

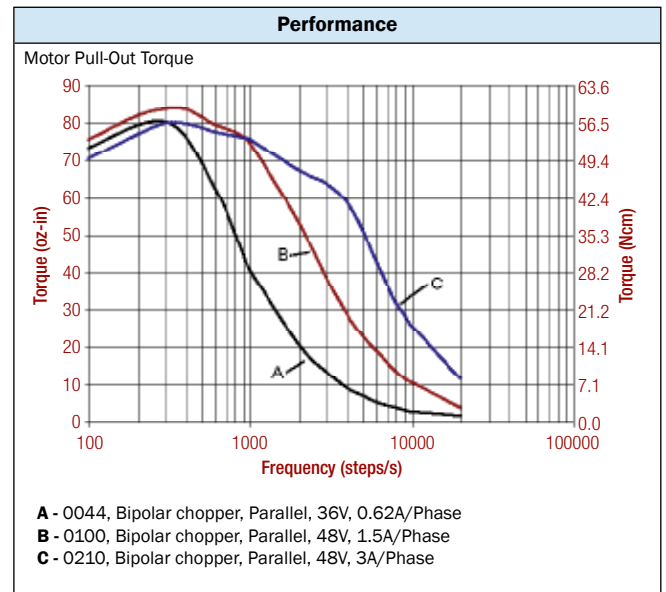

Available through the MotionExpress program.

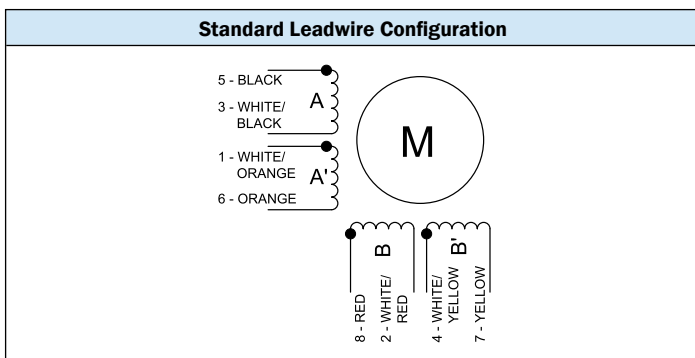

- Standard Features**
- Step angle: 1.8°
 - Step angle accuracy: 5%
 - Insulation class: B (130°C)
 - NEMA 23 mounting configuration
 - AlNiCo magnets
 - Additional windings and customization options available
 - CE approved

- Complementary Products**
- Gearboxes
 - Encoders

SIZE 23 STEPPER MOTOR DATA

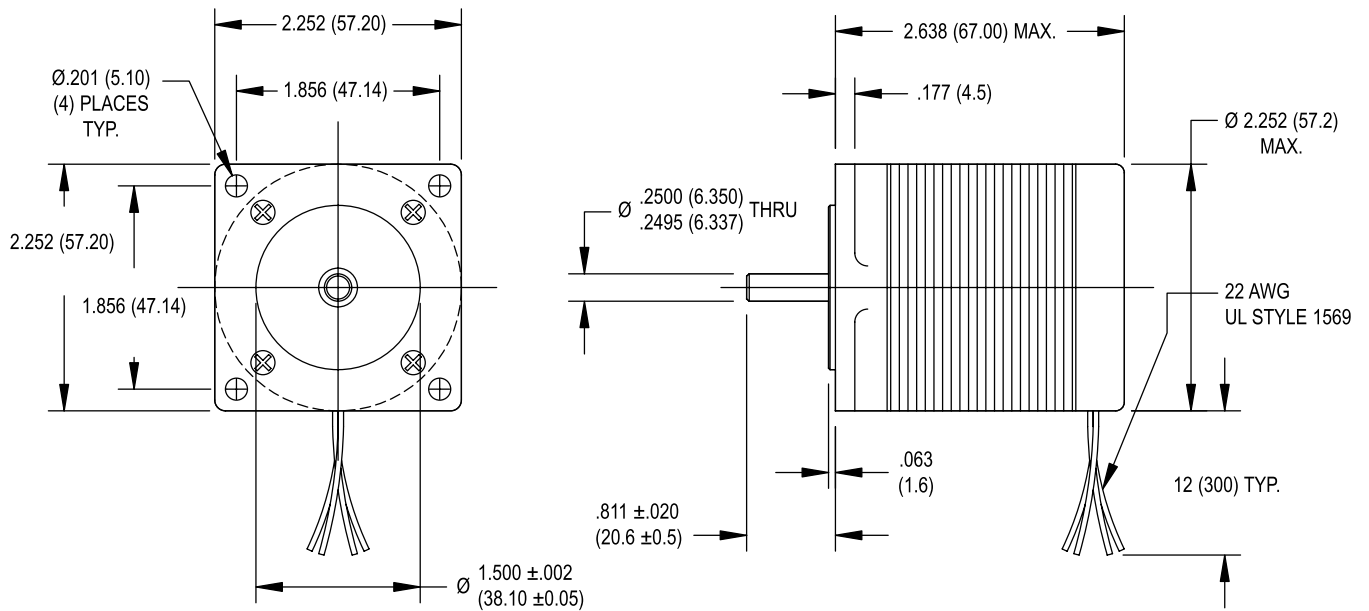

| Specification | Units | HY 200 2226 | | | |
|-------------------------|--|-------------|------|------|------|
| | | 0160 | 0190 | 0250 | 0470 |
| Rated Phase Current | A | 1.60 | 1.90 | 2.50 | 4.70 |
| Phase Resistance | Ω | 2.6 | 1.8 | 1.1 | 0.33 |
| Phase Inductance | mH | 4.7 | 3.3 | 4.0 | 0.5 |
| Holding Torque Unipolar | oz-in | 123 | 126 | — | 123 |
| | Ncm | 87 | 89 | — | 87 |
| Holding Torque Bipolar | oz-in | 154 | 160 | 161 | 154 |
| | Ncm | 109 | 113 | 114 | 109 |
| Detent Torque | oz-in | 12.0 | 12.0 | 12.0 | 12.0 |
| | Ncm | 8.5 | 8.5 | 8.5 | 8.5 |
| Rotor Inertia | oz-in-s ² x10 ⁻⁴ | 28 | 28 | 28 | 28 |
| | g-cm ² | 200 | 200 | 200 | 200 |
| Motor Weight (Mass) | lb | 1.5 | 1.5 | 1.5 | 1.5 |
| | kg | 0.70 | 0.70 | 0.70 | 0.70 |
| Maximum Voltage | V | 75 | 75 | 75 | 75 |
| Std. No. of Leads | — | 8 | 8 | 4 | 8 |

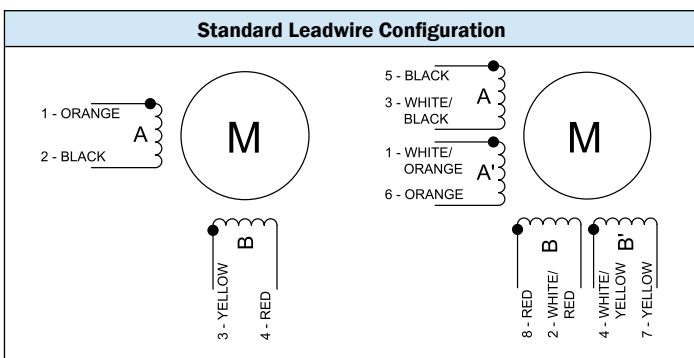
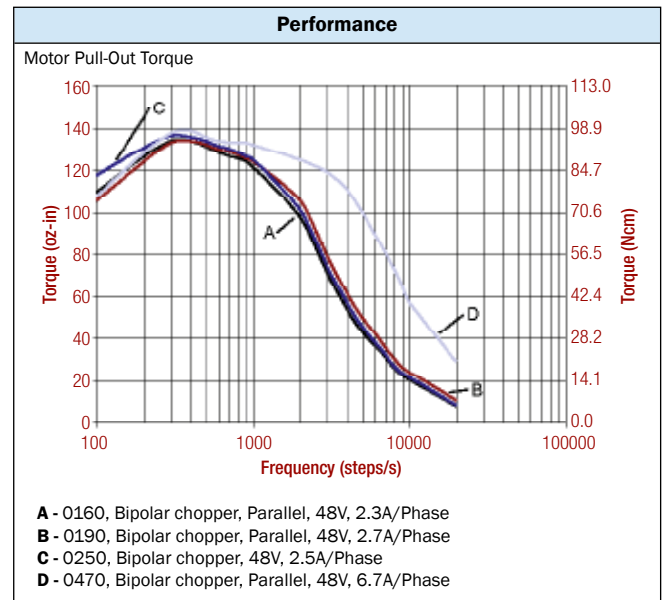

- ### Standard Features
- Step angle: 1.8°
 - Step angle accuracy: 5%
 - Insulation class: B (130 °C)
 - NEMA 23 mounting configuration
 - Neodymium magnets
 - Additional windings and customization options available
 - CE approved

- ### Complementary Products
- Gearboxes
 - Encoders

SIZE 23 HIGH PERFORMANCE STEPPER MOTOR DATA

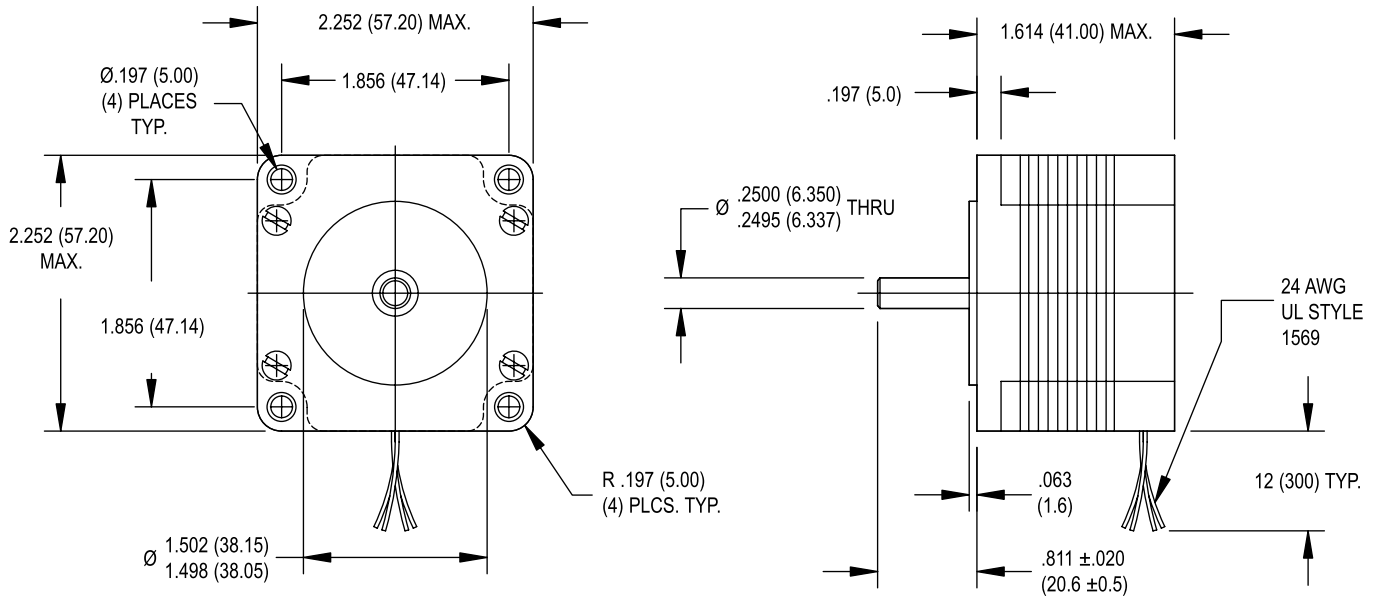

| Specification | Units | HS 200 2216 | |
|-------------------------|--|-------------|------|
| | | 0100 | 0210 |
| Rated Phase Current | A | 1.00 | 2.10 |
| Phase Resistance | Ω | 4.6 | 1.0 |
| Phase Inductance | mH | 4.6 | 2.1 |
| Holding Torque Unipolar | oz-in | 52 | — |
| | Ncm | 37 | — |
| Holding Torque Bipolar | oz-in | 67 | 67 |
| | Ncm | 47 | 47 |
| Detent Torque | oz-in | 3.0 | 3.0 |
| | Ncm | 2.1 | 2.1 |
| Rotor Inertia | oz-in-s ² x10 ⁻⁴ | 11 | 11 |
| | g-cm ² | 77 | 77 |
| Motor Weight (Mass) | lb | 1.1 | 1.1 |
| | kg | 0.50 | 0.50 |
| Maximum Voltage | V | 75 | 75 |
| Std. No. of Leads | — | 8 | 4 |

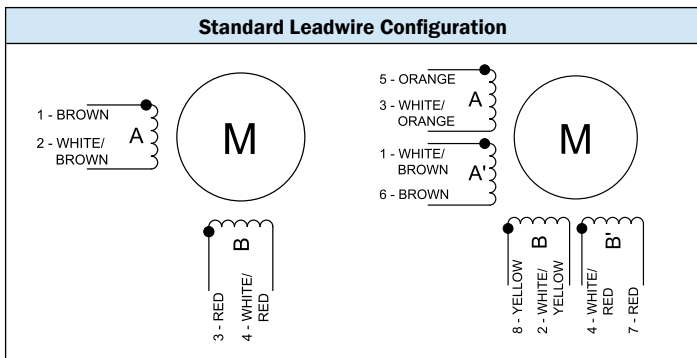
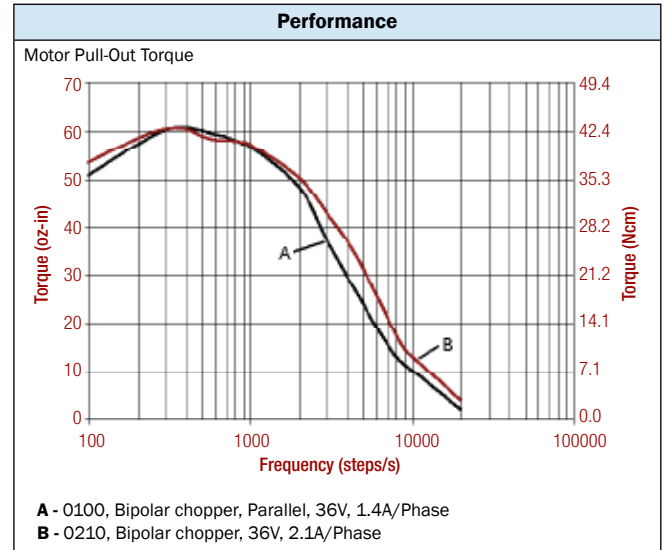

- Standard Features**
- Step angle: 1.8°
 - Step angle accuracy: 5%
 - Insulation class: B (130°C)
 - Optimized for microstep operation
 - NEMA 23 mounting configuration
 - Neodymium magnets
 - Additional windings and customization options available
 - CE approved

- Complementary Products**
- Gearboxes
 - Encoders

SIZE 23 HIGH PERFORMANCE STEPPER MOTOR DATA

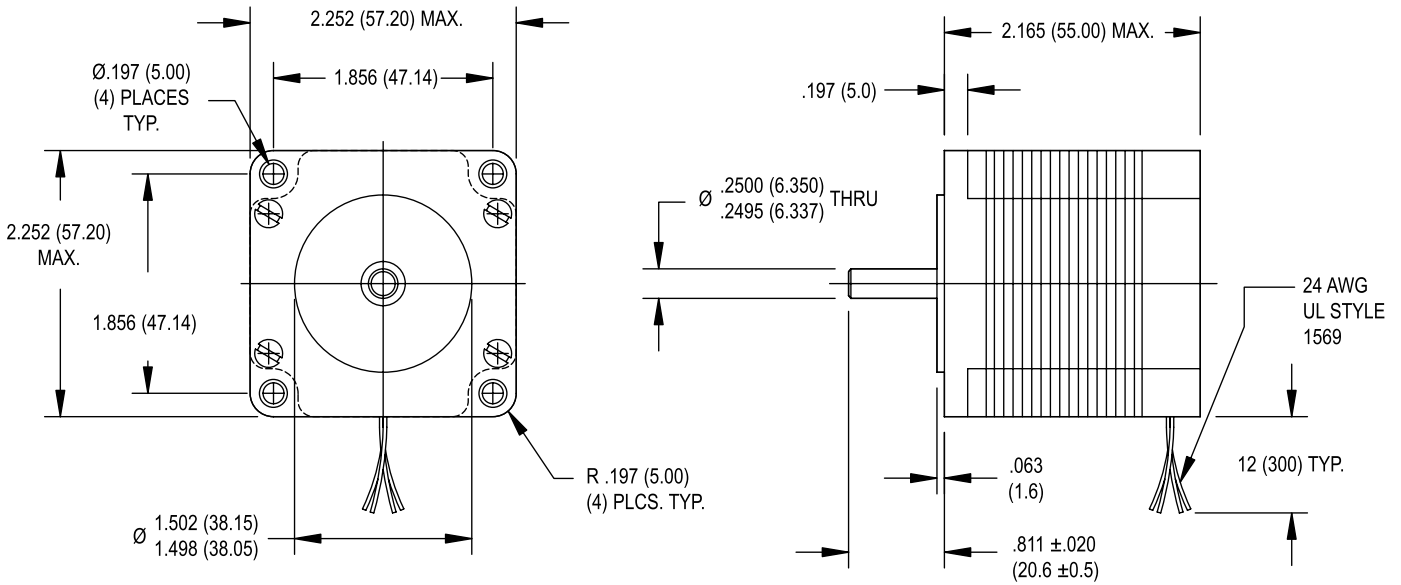

| Specification | Units | HS 200 2221 | | |
|-------------------------|--|-------------|------|------|
| | | 0100 | 0210 | 0300 |
| Rated Phase Current | A | 1.00 | 2.10 | 3.00 |
| Phase Resistance | Ω | 6.2 | 1.4 | 0.7 |
| Phase Inductance | mH | 8.8 | 3.9 | 0.9 |
| Holding Torque Unipolar | oz-in | 106 | — | 106 |
| | Ncm | 75 | — | 75 |
| Holding Torque Bipolar | oz-in | 139 | 139 | 139 |
| | Ncm | 98 | 98 | 98 |
| Detent Torque | oz-in | 5.7 | 5.7 | 5.7 |
| | Ncm | 4.0 | 4.0 | 4.0 |
| Rotor Inertia | oz-in-s ² x10 ⁻⁴ | 31 | 31 | 31 |
| | g-cm ² | 220 | 220 | 220 |
| Motor Weight (Mass) | lb | 1.5 | 1.5 | 1.5 |
| | kg | 0.70 | 0.70 | 0.70 |
| Maximum Voltage | V | 75 | 75 | 75 |
| Std. No. of Leads | — | 8 | 4 | 8 |

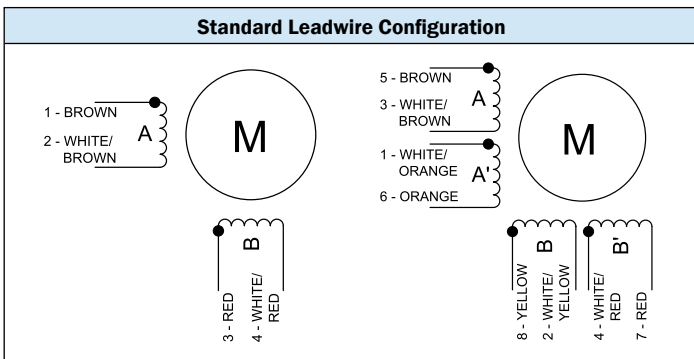
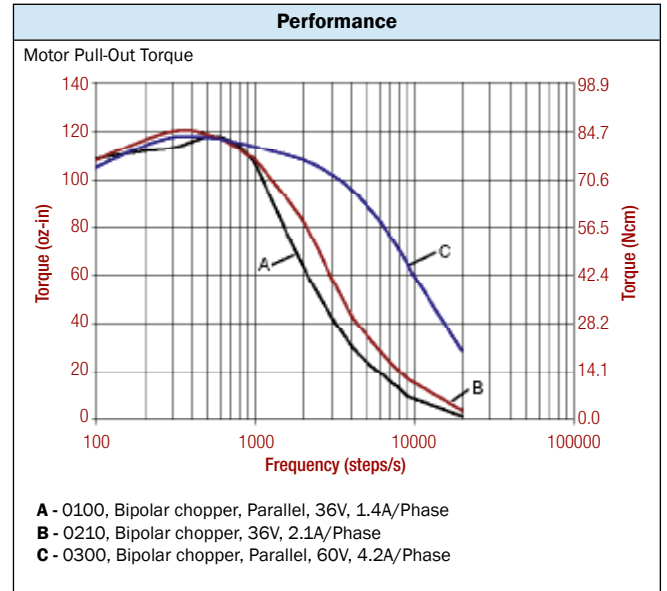

- ### Standard Features
- Step angle: 1.8°
 - Step angle accuracy: 5%
 - Insulation class: B (130 °C)
 - Optimized for microstep operation
 - NEMA 23 mounting configuration
 - AlNiCo magnets
 - Additional windings and customization options available
 - CE approved

- ### Complementary Products
- Gearboxes
 - Encoders

SIZE 23 HIGH PERFORMANCE STEPPER MOTOR DATA

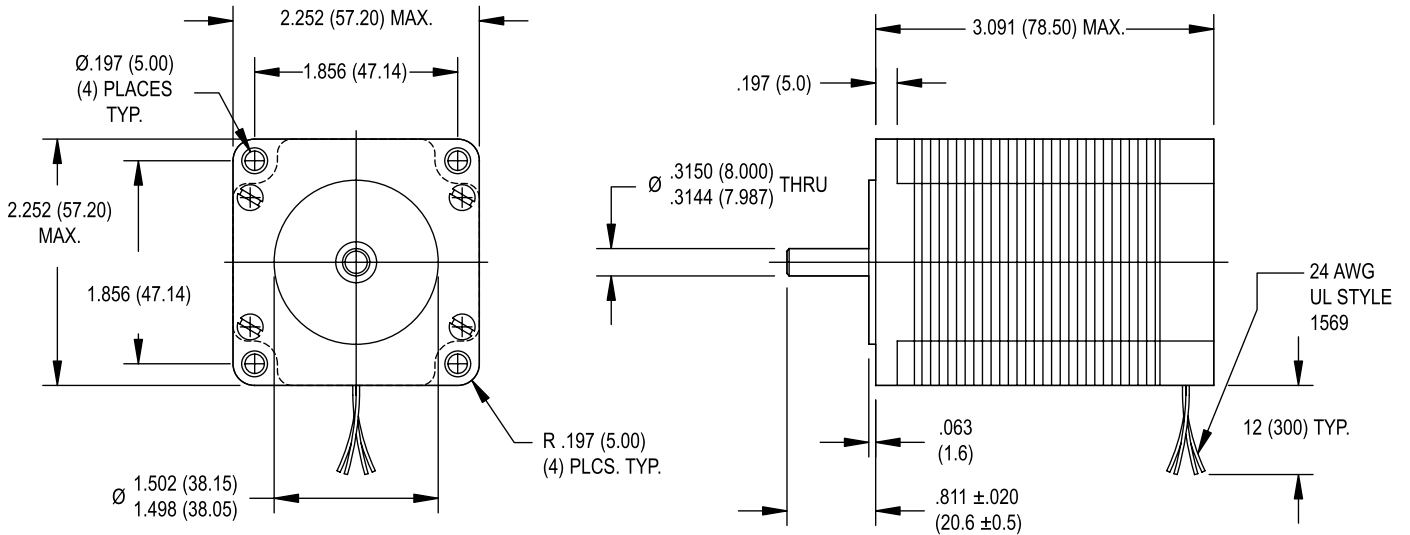

| Specification | Units | HS 200 2231 | |
|-------------------------|--|-------------|------------|
| | | 0210 | 0300 |
| Rated Phase Current | A | 2.10 | 3.00 |
| Phase Resistance | Ω | 2.0 | 1.1 |
| Phase Inductance | mH | 6.5 | 1.7 |
| Holding Torque Unipolar | oz-in Ncm | — | 177 125 |
| Holding Torque Bipolar | oz-in Ncm | 228 161 | 231 163 |
| Detent Torque | oz-in Ncm | 9.6 6.8 | 9.6 6.8 |
| Rotor Inertia | oz-in-s ² $\times 10^{-4}$ g-cm ² | 48 340 | 48 340 |
| Motor Weight (Mass) | lb kg | 2.2 1.0 | 2.2 1.0 |
| Maximum Voltage | V | 75 | 75 |
| Std. No. of Leads | — | 4 | 8 |

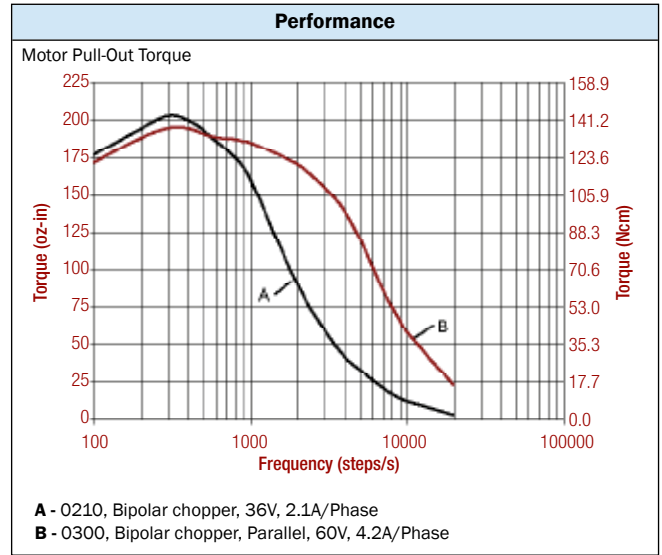

Available through the MotionExpress program.

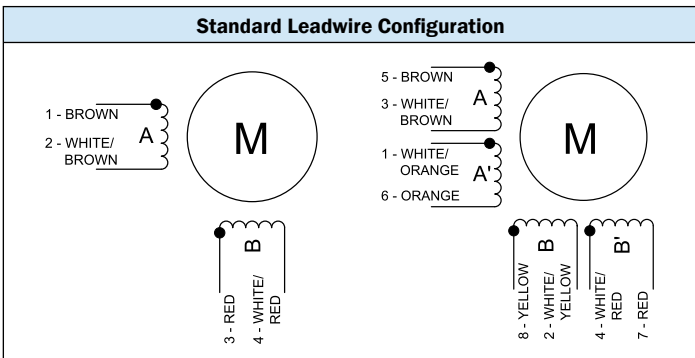

- Standard Features**
- Step angle: 1.8°
 - Step angle accuracy: 5%
 - Insulation class: B (130°C)
 - Optimized for microstep operation
 - NEMA 23 mounting configuration
 - AlNiCo magnets
 - Additional windings and customization options available
 - CE approved

- Complementary Products**
- Gearboxes
 - Encoders

SIZE 23 HIGH PERFORMANCE STEPPER MOTOR DATA

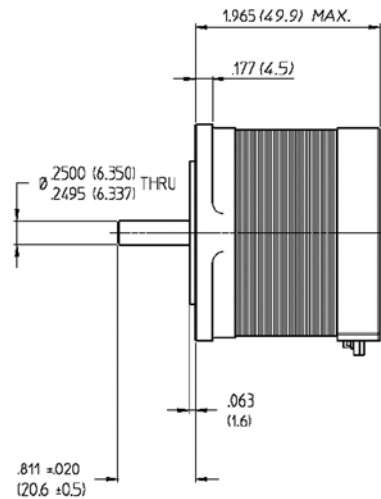
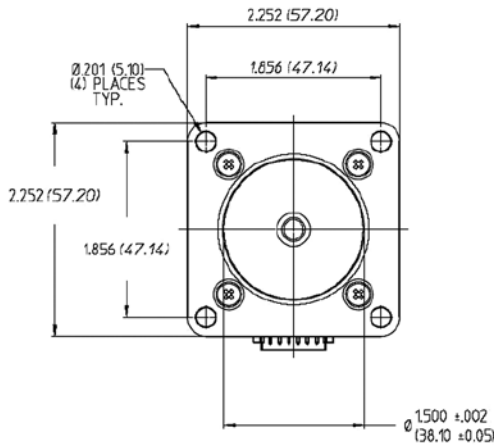

| Specification | Units | HT 200 2220 |
|---------------------------|---|-------------|
| | | 0200 |
| Rated Phase Current | A | 2.00 |
| Phase Resistance | Ω | 1.20 |
| Phase Inductance | mH | 3.40 |
| Holding Torque Bipolar | oz-in | 113 |
| | Ncm | 80 |
| Detent Torque | oz-in | 8.5 |
| | Ncm | 6 |
| Rotor Inertia | oz-in-s ² × 10 ⁻⁴ | 18.7 |
| | g-cm ² | 132 |
| Motor Weight (Mass) | lb | 1.1 |
| | kg | 0.5 |
| Maximum Voltage | V | 75 |
| Connector | S6B-EH "JTS" | |

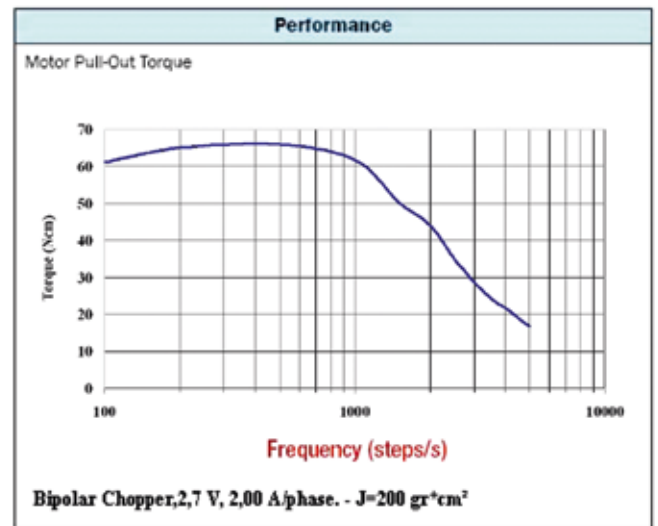

- Standard Features**
- Step angle: 1.8°
 - Step angle accuracy: 5%
 - Insulation class: B (130°C)
 - NEMA 23 mounting configuration
 - Additional windings and customization options available

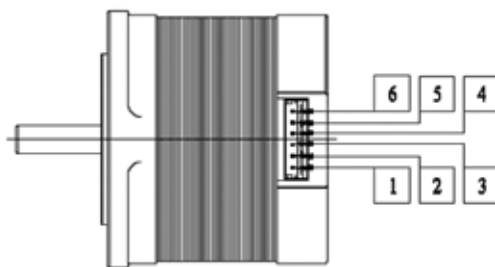

| Step # | Coil excitation: The current is flowing in direction of: |
|--------|---|
| 1 | A, D |
| 1 | A, C |
| 1 | B, C |
| 1 | B, D |

CCW rotation from front side using commutation sequence as table above

SIZE 34 STEPPER MOTOR DATA

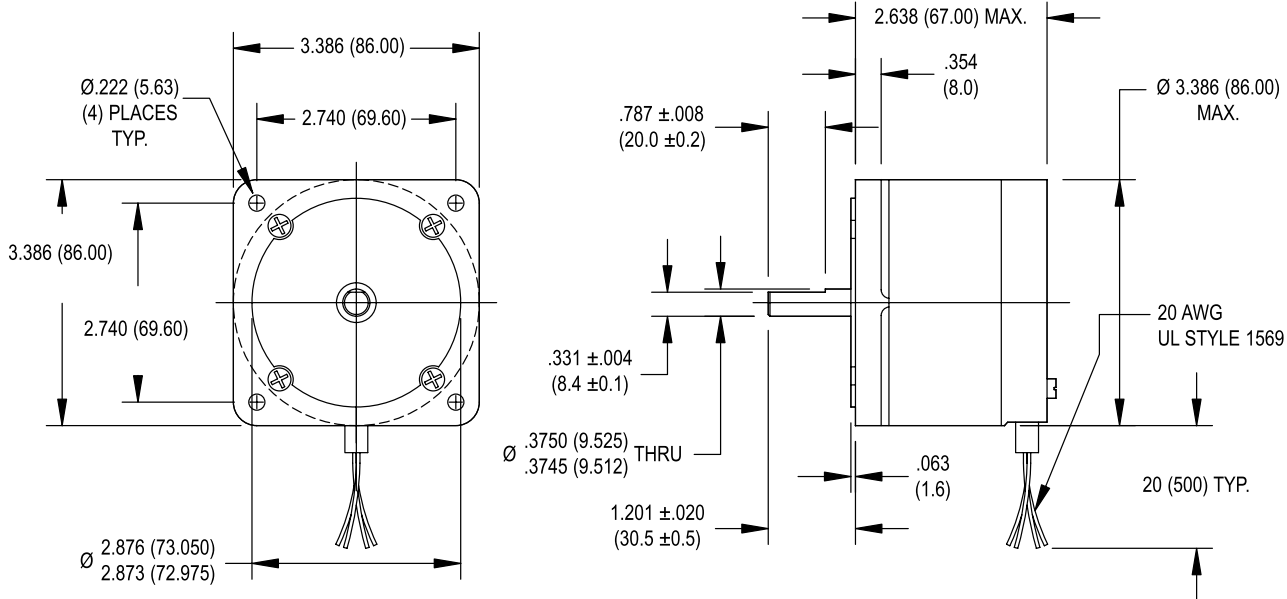

| Specification | Units | HN 200 3426 | | |
|-------------------------|---------------------------------------|-------------|------|------|
| | | 0140 | 0280 | 0430 |
| Rated Phase Current | A | 1.40 | 2.80 | 4.30 |
| Phase Resistance | Ω | 5.0 | 1.3 | 0.55 |
| Phase Inductance | mH | 21 | 5.1 | 2.1 |
| Holding Torque Unipolar | oz-in | 326 | 326 | 326 |
| | Ncm | 230 | 230 | 230 |
| Holding Torque Bipolar | oz-in | 397 | 397 | 397 |
| | Ncm | 280 | 280 | 280 |
| Detent Torque | oz-in | 12 | 12 | 12 |
| | Ncm | 8.5 | 8.5 | 8.5 |
| Rotor Inertia | oz-in-s ² $\times 10^{-4}$ | 93 | 93 | 93 |
| | g-cm ² | 660 | 660 | 660 |
| Motor Weight (Mass) | lb | 3.5 | 3.5 | 3.5 |
| | kg | 1.6 | 1.6 | 1.6 |
| Maximum Voltage | V | 90 | 90 | 90 |
| Std. No. of Leads | — | 8 | 8 | 8 |

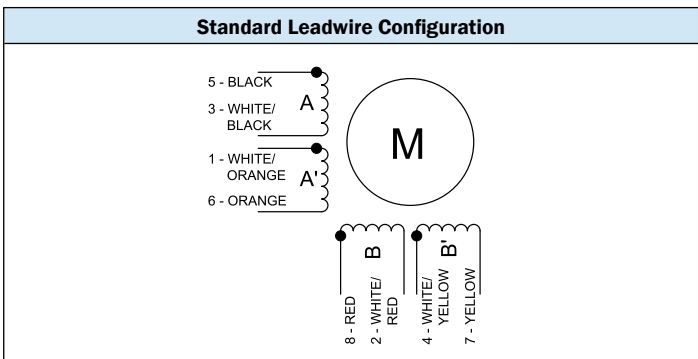
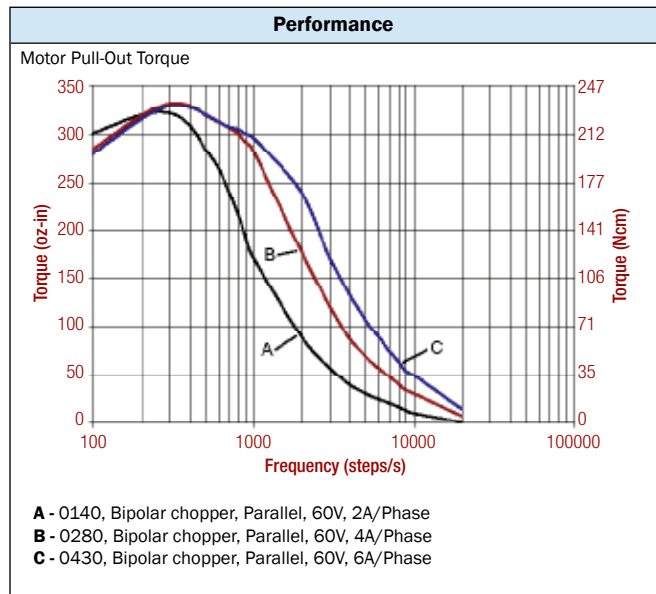

- ### Standard Features
- Step angle: 1.8°
 - Step angle accuracy: 5%
 - Insulation class: B (130° C)
 - NEMA 34 mounting configuration
 - Neodymium magnets
 - Additional windings and customization options available
 - CE approved

- ### Complementary Products
- Gearboxes
 - Encoders

SIZE 34 STEPPER MOTOR DATA

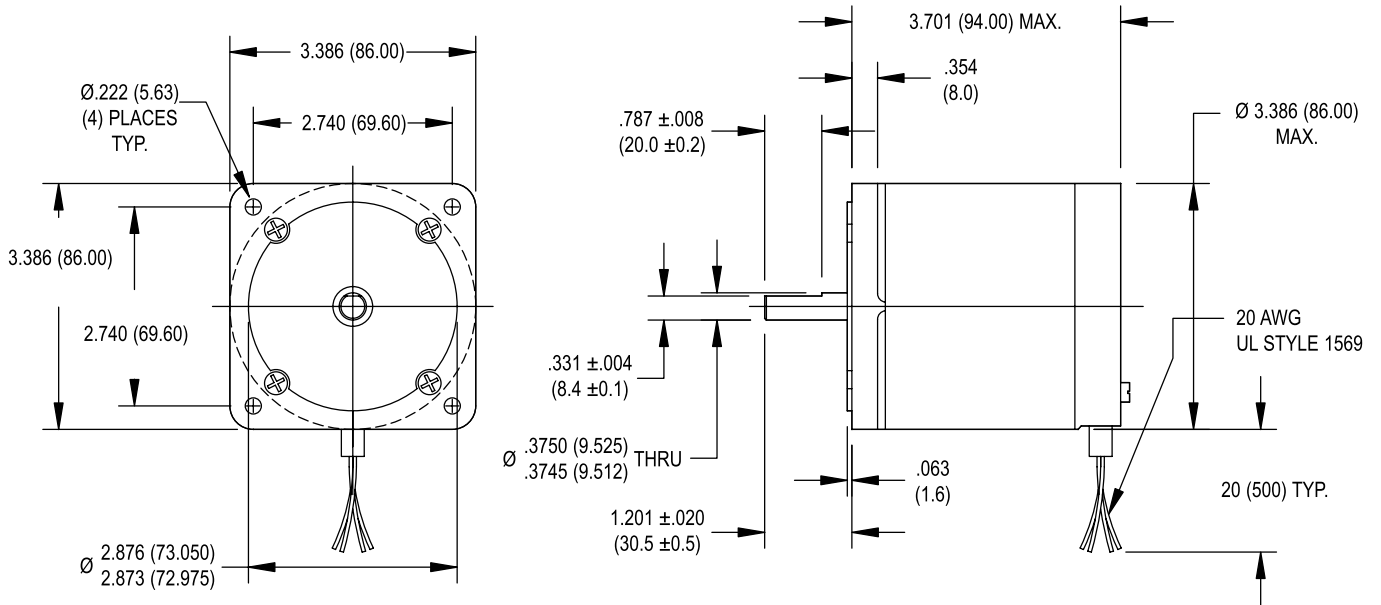

| Specification | Units | HN 200 3438 | |
|-------------------------|--|-------------|-------------|
| | | 0280 | 0430 |
| Rated Phase Current | A | 2.80 | 4.30 |
| Phase Resistance | Ω | 1.7 | 0.75 |
| Phase Inductance | mH | 7.7 | 3.5 |
| Holding Torque Unipolar | oz-in Ncm | 538 380 | 538 380 |
| Holding Torque Bipolar | oz-in Ncm | 680 480 | 680 480 |
| Detent Torque | oz-in Ncm | 18 13 | 18 13 |
| Rotor Inertia | oz-in-s ² $\times 10^{-4}$ g-cm ² | 170 1200 | 170 1200 |
| Motor Weight (Mass) | lb kg | 5.3 2.4 | 5.3 2.4 |
| Maximum Voltage | V | 90 | 90 |
| Std. No. of Leads | — | 8 | 8 |

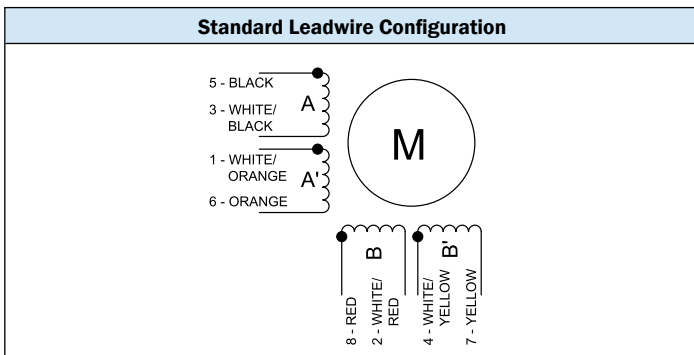
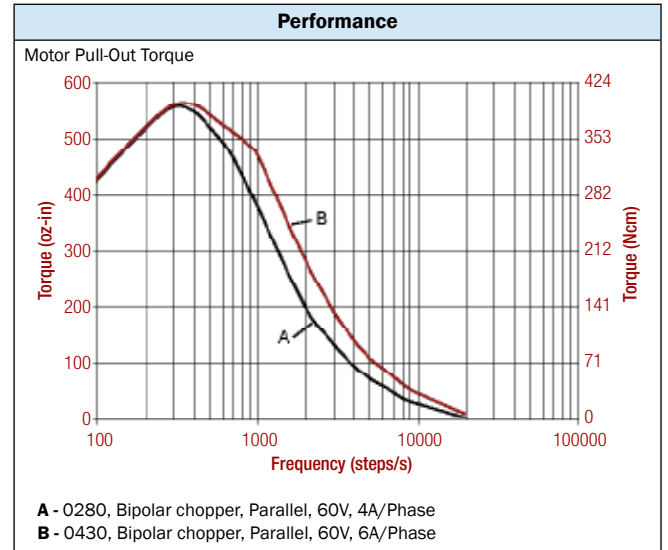

- Standard Features**
- Step angle: 1.8°
 - Step angle accuracy: 5%
 - Insulation class: B (130°C)
 - NEMA 34 mounting configuration
 - Neodymium magnets
 - Additional windings and customization options available
 - CE approved

- Complementary Products**
- Gearboxes
 - Encoders

SIZE 34 STEPPER MOTOR DATA

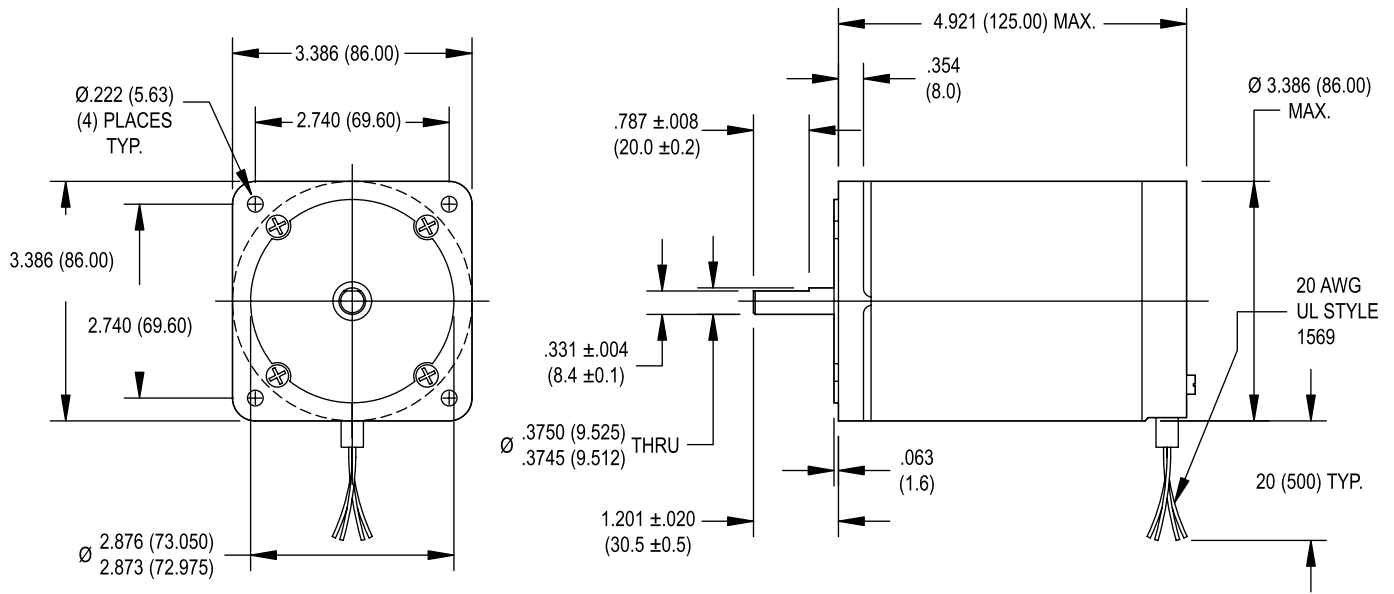

| Specification | Units | HN 200 3451 | |
|-------------------------|--|-------------|------|
| | | 0350 | 0640 |
| Rated Phase Current | A | 3.50 | 6.40 |
| Phase Resistance | Ω | 1.5 | 0.50 |
| Phase Inductance | mH | 8.5 | 2.5 |
| Holding Torque Unipolar | oz-in | 878 | 878 |
| | Ncm | 620 | 620 |
| Holding Torque Bipolar | oz-in | 1076 | 1076 |
| | Ncm | 760 | 760 |
| Detent Torque | oz-in | 33 | 33 |
| | Ncm | 23 | 23 |
| Rotor Inertia | oz-in-s ² x10 ⁻⁴ | 255 | 255 |
| | g-cm ² | 1800 | 1800 |
| Motor Weight (Mass) | lb | 7.9 | 7.9 |
| | kg | 3.6 | 3.6 |
| Maximum Voltage | V | 140 | 140 |
| Std. No. of Leads | - | 8 | 8 |

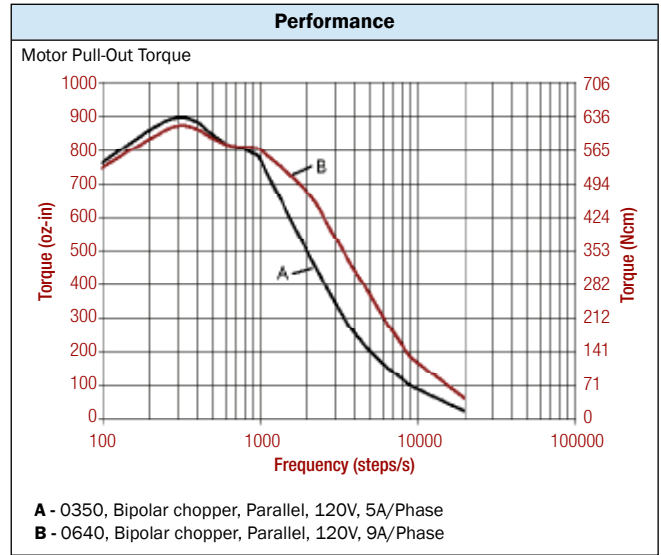

- Standard Features**
- Step angle: 1.8°
 - Step angle accuracy: 5%
 - Insulation class: B (130°C)
 - NEMA 34 mounting configuration
 - Neodymium magnets
 - Additional windings and customization options available
 - CE approved

- Complementary Products**
- Gearboxes
 - Encoders

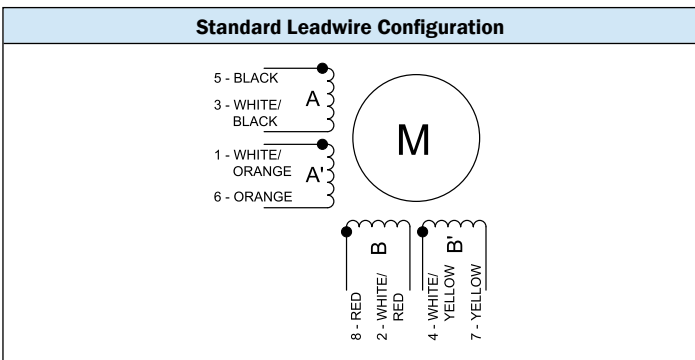

SIZE 34 HIGH PERFORMANCE STEPPER MOTOR DATA

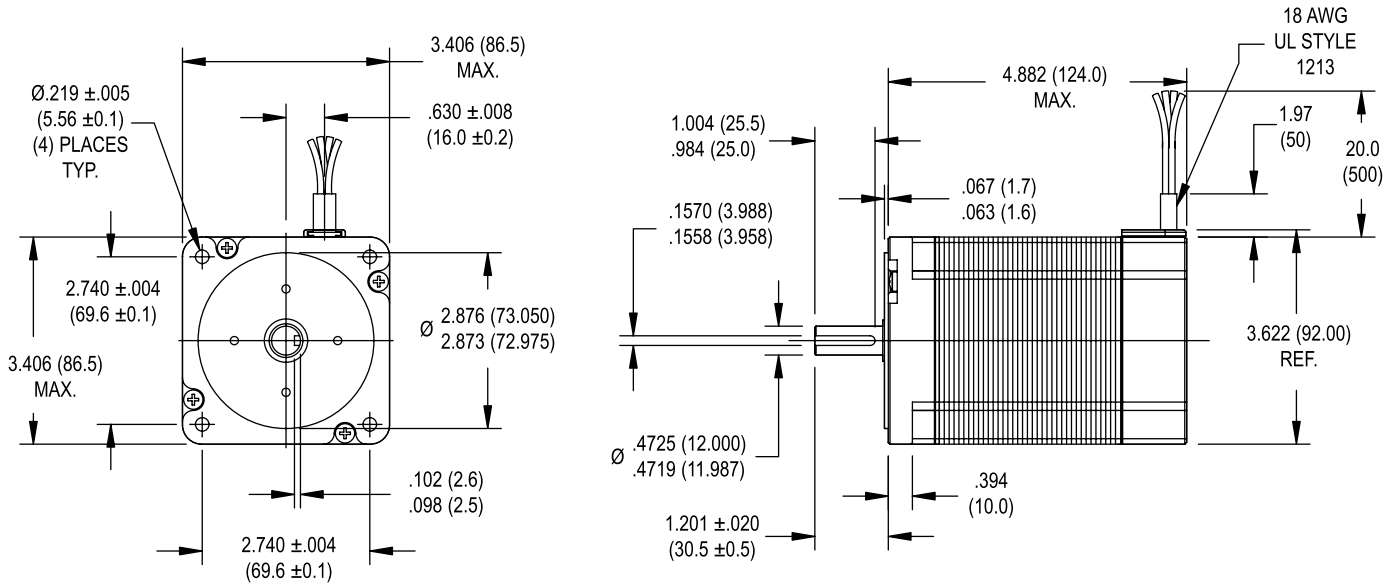

| Specification | Units | HS 200 3448 | | |
|-------------------------|--|-------------|-------------|-------------|
| | | 0300 | 0550 | 0800 |
| Rated Phase Current | A | 3.00 | 5.50 | 8.00 |
| Phase Resistance | Ω | 1.56 | 0.46 | 0.22 |
| Phase Inductance | mH | 14 | 4.0 | 1.9 |
| Holding Torque Unipolar | oz-in Ncm | — | — | — |
| Holding Torque Bipolar | oz-in Ncm | 1062 750 | 1062 750 | 1062 750 |
| Detent Torque | oz-in Ncm | 28 20 | 28 20 | 28 20 |
| Rotor Inertia | oz-in-s ² $\times 10^{-4}$ g-cm ² | 548 3870 | 548 3870 | 548 3870 |
| Motor Weight (Mass) | lb kg | 8.8 4.0 | 8.8 4.0 | 8.8 4.0 |
| Maximum Voltage | V | 160 | 160 | 160 |
| Std. No. of Leads | — | 4 | 4 | 4 |

Performance

Motor Pull-Out Torque

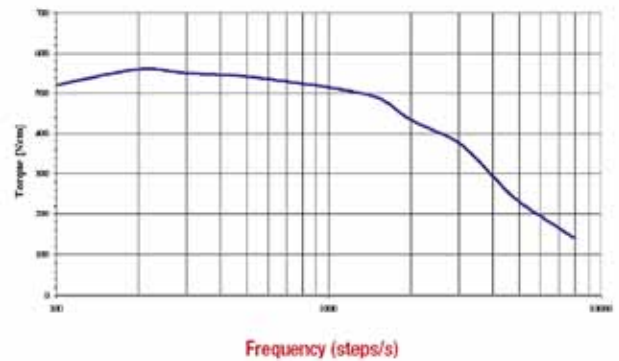

A - 0550, Bipolar chopper, 120V, 5.5A/Phase, $J_L = 12000 \text{ g cm}^2$

Standard Features

- Step angle: 1.8°
- Step angle accuracy: 5%
- Insulation class: B (130° C)
- Optimized for microstep operation
- NEMA 34 mounting configuration
- Neodymium magnets
- Additional windings and customization options available
- CE approval pending

Complementary Products

- Gearboxes
- Encoders

Standard Leadwire Configuration

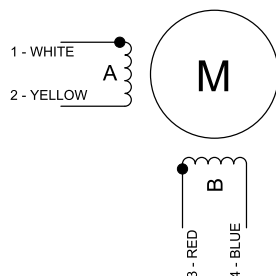

SIZE 34 HIGH PERFORMANCE STEPPER MOTOR DATA

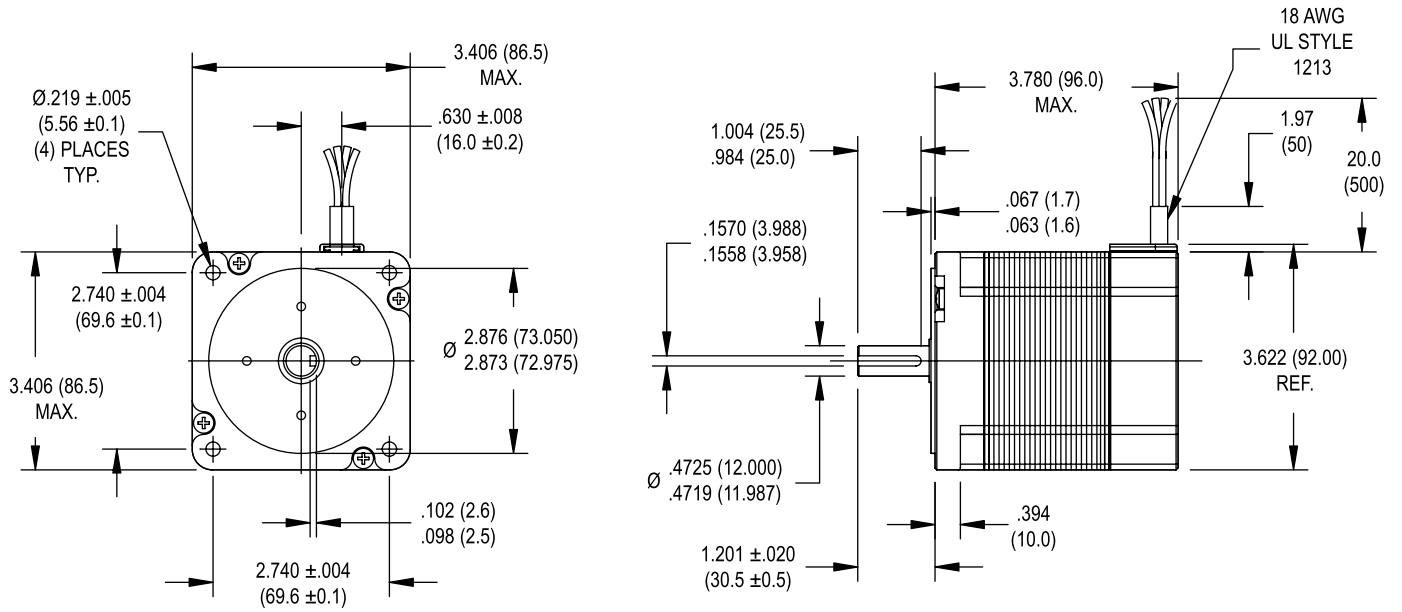

| Specification | Units | HS 200 3437 | | |
|-------------------------|--|-------------|-------------|-------------|
| | | 0300 | 0550 | 0800 |
| Rated Phase Current | A | 3.00 | 5.50 | 8.00 |
| Phase Resistance | Ω | 1.37 | 0.42 | 0.19 |
| Phase Inductance | mH | 11 | 3.6 | 1.6 |
| Holding Torque Unipolar | oz-in Ncm | — | — | — |
| Holding Torque Bipolar | oz-in Ncm | 779 550 | 779 550 | 779 550 |
| Detent Torque | oz-in Ncm | 28 20 | 28 20 | 28 20 |
| Rotor Inertia | oz-in-s ² × 10 ⁻⁴ g-cm ² | 490 3460 | 490 3460 | 490 3460 |
| Motor Weight (Mass) | lb kg | 6.6 3.0 | 6.6 3.0 | 6.6 3.0 |
| Maximum Voltage | V | 160 | 160 | 160 |
| Std. No. of Leads | — | 4 | 4 | 4 |

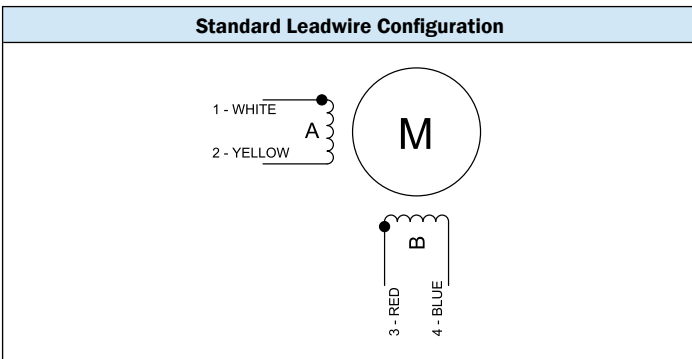
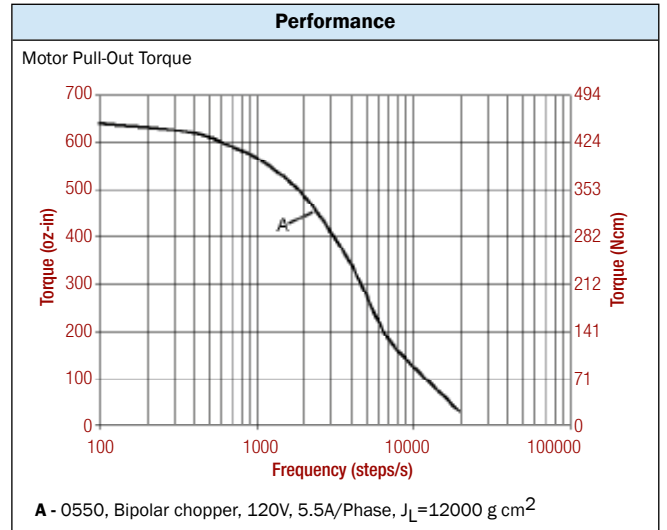

- ### Standard Features
- Step angle: 1.8°
 - Step angle accuracy: 5%
 - Insulation class: B (130° C)
 - Optimized for microstep operation
 - NEMA 34 mounting configuration
 - Neodymium magnets
 - Additional windings and customization options available
 - CE approval pending

- ### Complementary Products
- Gearboxes
 - Encoders

SIZE 34 HIGH PERFORMANCE STEPPER MOTOR DATA

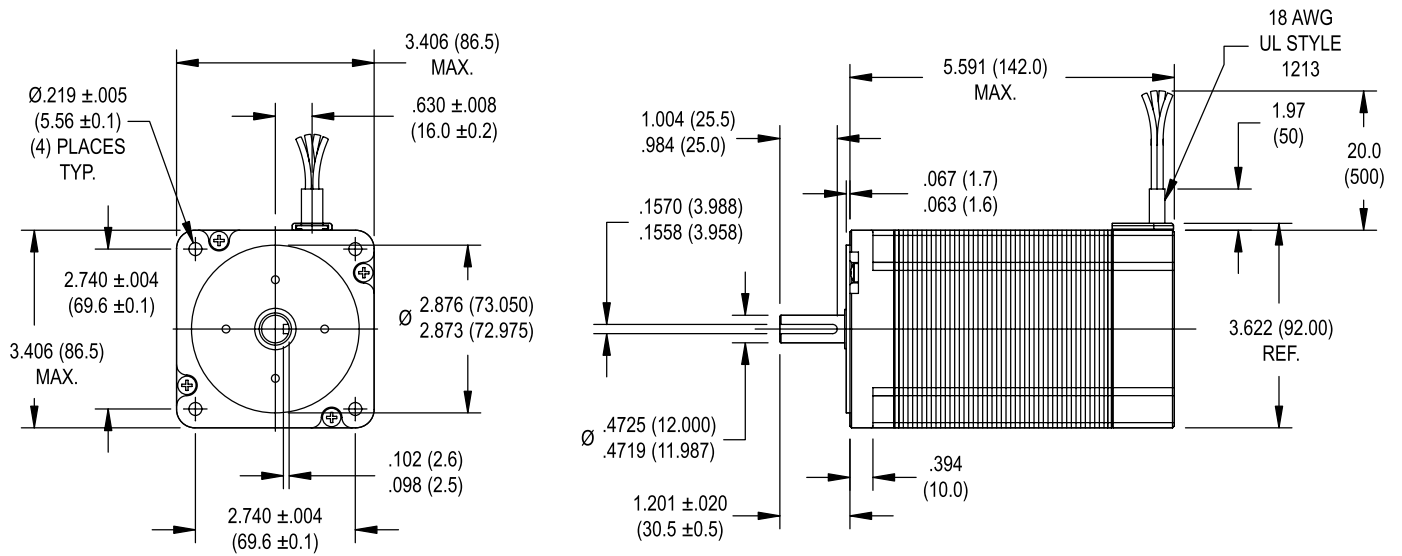

| Specification | Units | HS 200 3455 | | |
|-------------------------|---|--------------|--------------|--------------|
| | | 0300 | 0550 | 0800 |
| Rated Phase Current | A | 3.00 | 5.50 | 8.00 |
| Phase Resistance | Ω | 1.70 | 0.55 | 0.29 |
| Phase Inductance | mH | 20 | 5.6 | 2.6 |
| Holding Torque Unipolar | oz-in Ncm | — | — | — |
| Holding Torque Bipolar | oz-in Ncm | 1416 1000 | 1416 1000 | 1416 1000 |
| Detent Torque | oz-in Ncm | 42 30 | 42 30 | 42 30 |
| Rotor Inertia | oz-in-s ² x10 ⁻⁴ g-cm ² | 694 4900 | 694 4900 | 694 4900 |
| Motor Weight (Mass) | lb kg | 10.8 4.9 | 10.8 4.9 | 10.8 4.9 |
| Maximum Voltage | V | 160 | 160 | 160 |
| Std. No. of Leads | — | 4 | 4 | 4 |

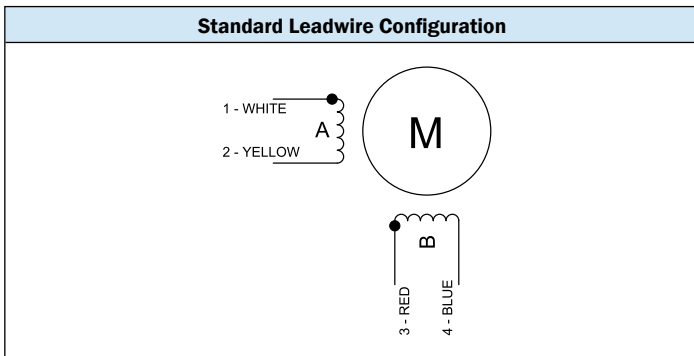
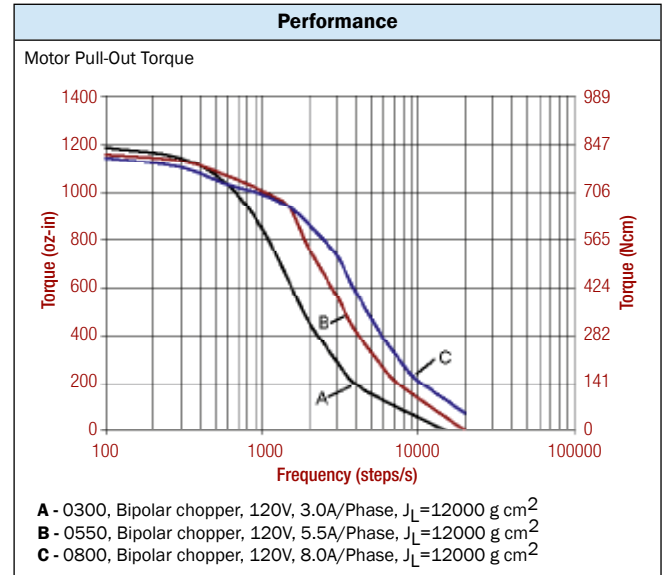

- Standard Features**
- Step angle: 1.8°
 - Step angle accuracy: 5%
 - Insulation class: B (130° C)
 - Optimized for microstep operation
 - NEMA 34 mounting configuration
 - Neodymium magnets
 - Additional windings and customization options available
 - CE approval pending

- Complementary Products**
- Gearboxes
 - Encoders

SIZE 42 STEPPER MOTOR DATA

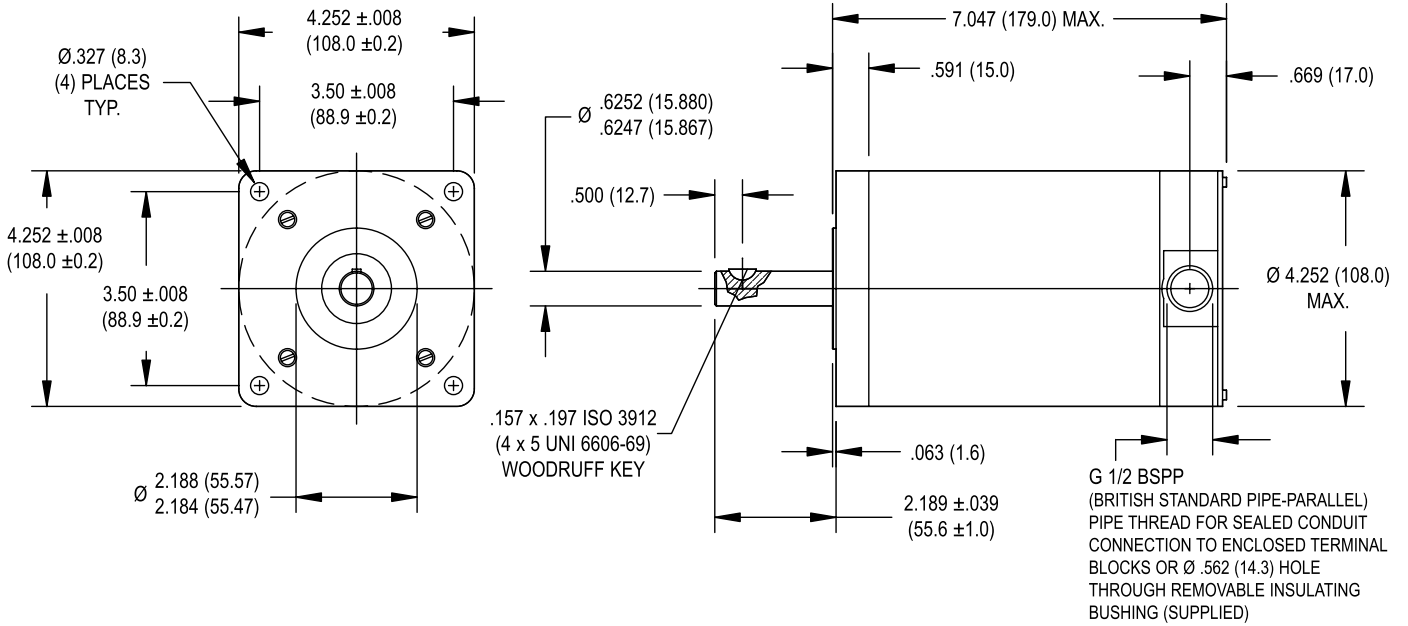

| Specification | Units | HY 200 4270 | | |
|-------------------------|--|-------------|------|------|
| | | 0340 | 0710 | 0900 |
| Rated Phase Current | A | 3.40 | 7.10 | 9.00 |
| Phase Resistance | Ω | 1.1 | 0.30 | 0.34 |
| Phase Inductance | mH | 6.3 | 2.0 | 2.7 |
| Holding Torque Unipolar | oz-in | 1130 | 1175 | 1450 |
| | Ncm | 798 | 830 | 1024 |
| Holding Torque Bipolar | oz-in | 1402 | 1459 | 1798 |
| | Ncm | 990 | 1030 | 1270 |
| Detent Torque | oz-in | 99 | 99 | 99 |
| | Ncm | 70 | 70 | 70 |
| Rotor Inertia | oz-in-s ² x10 ⁻⁴ | 779 | 779 | 779 |
| | g-cm ² | 5500 | 5500 | 5500 |
| Motor Weight (Mass) | lb | 16 | 16 | 16 |
| | kg | 7.3 | 7.3 | 7.3 |
| Maximum Voltage | V | 140 | 140 | 140 |
| Std. No. of Leads | — | 8 | 8 | 8 |

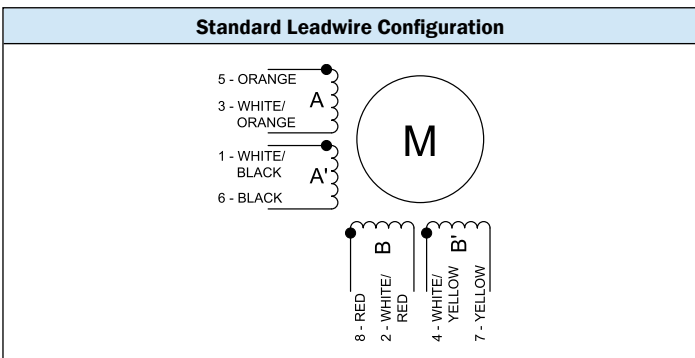
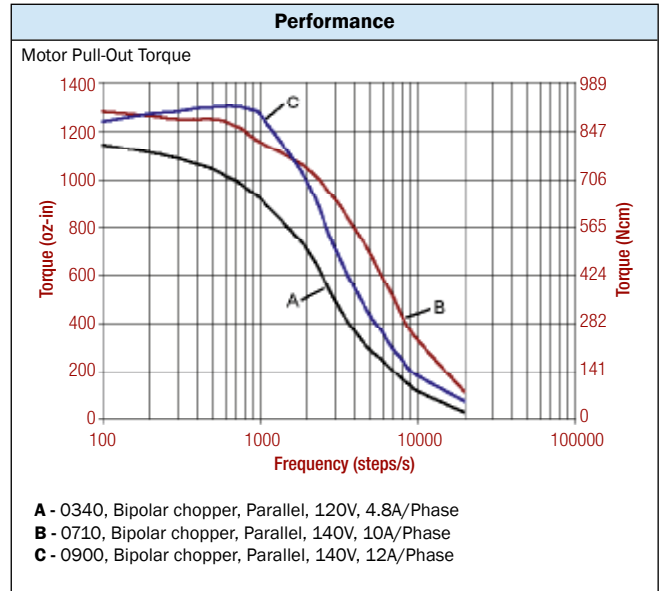

- Standard Features**
- Step angle: 1.8°
 - Step angle accuracy: 5%
 - Insulation class: B (130°C)
 - NEMA 42 mounting configuration
 - AlNiCo magnets
 - Additional windings and customization options available
 - CE approved

- Complementary Products**
- Gearboxes
 - Encoders

SIZE 42 STEPPER MOTOR DATA

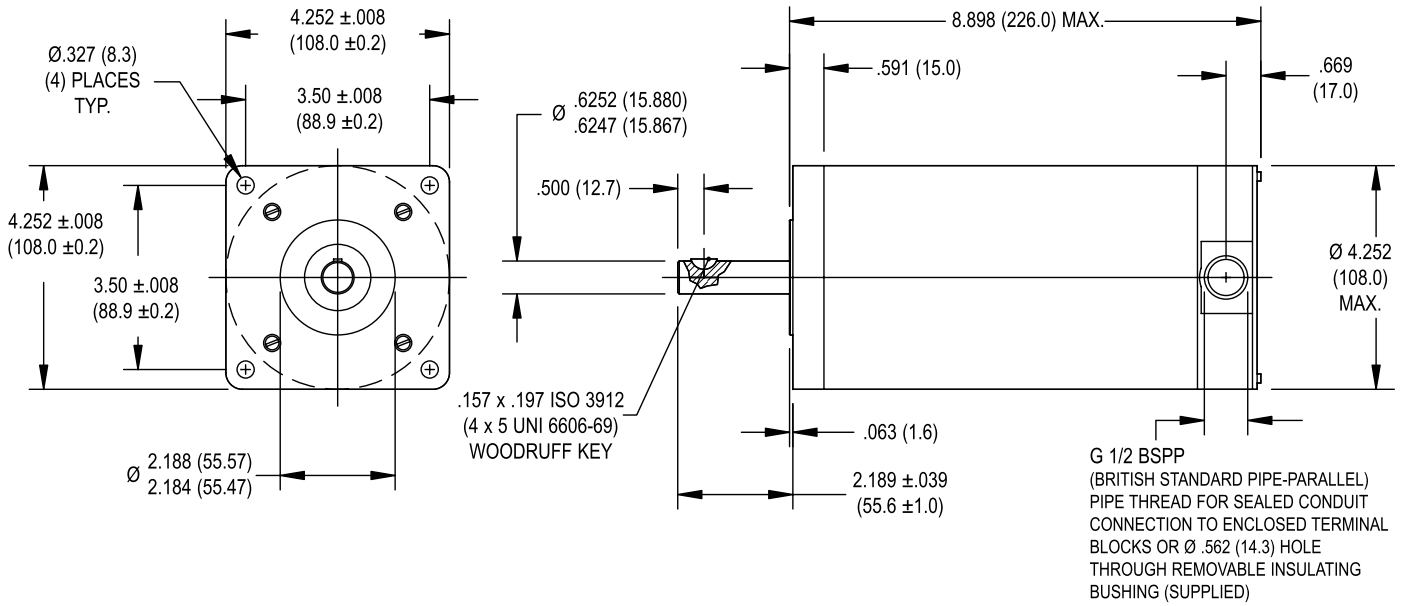

| Specification | Units | HY 200 4288 | |
|-------------------------|---------------------------------------|-------------|--|
| | | 0890 | |
| Rated Phase Current | A | 8.90 | |
| Phase Resistance | Ω | 0.31 | |
| Phase Inductance | mH | 2.3 | |
| Holding Torque Unipolar | oz-in | 1614 | |
| | Ncm | 1140 | |
| Holding Torque Bipolar | oz-in | 2018 | |
| | Ncm | 1425 | |
| Detent Torque | oz-in | 92 | |
| | Ncm | 65 | |
| Rotor Inertia | oz-in-s ² $\times 10^{-4}$ | 1175 | |
| | g-cm ² | 8300 | |
| Motor Weight (Mass) | lb | 23 | |
| | kg | 10.5 | |
| Maximum Voltage | V | 140 | |
| Std. No. of Leads | — | 8 | |

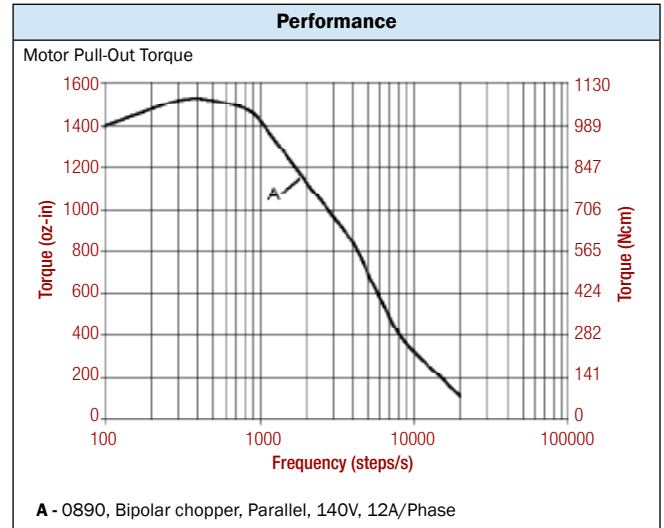

- ### Standard Features
- Step angle: 1.8°
 - Step angle accuracy: 5%
 - Insulation class: B (130°C)
 - NEMA 42 mounting configuration
 - AlNiCo magnets
 - Additional windings and customization options available
 - CE approved

- ### Complementary Products
- Gearboxes
 - Encoders

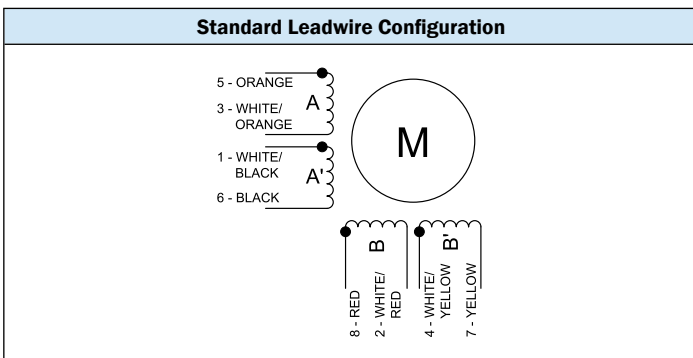

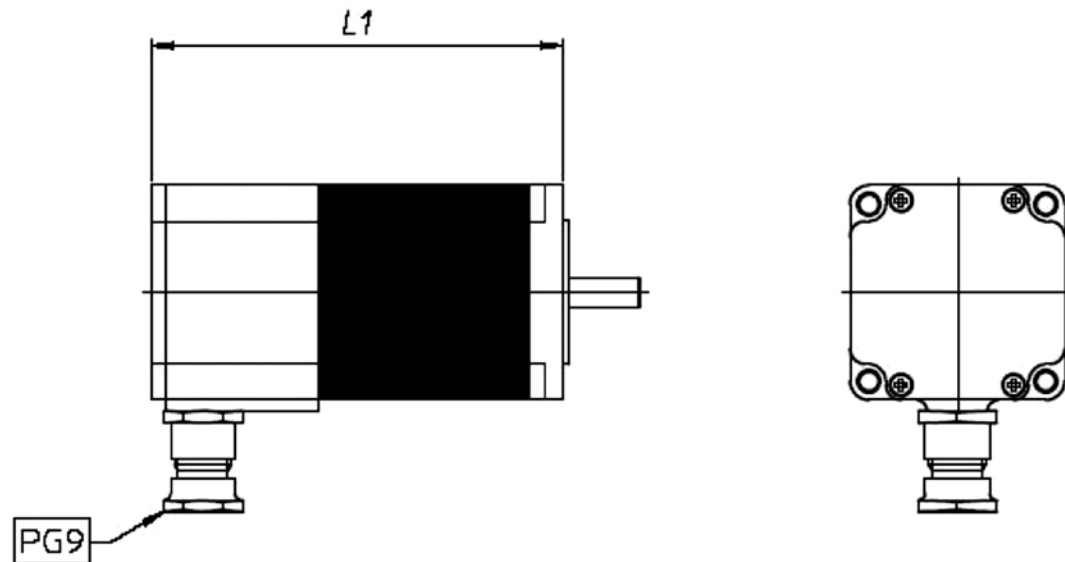
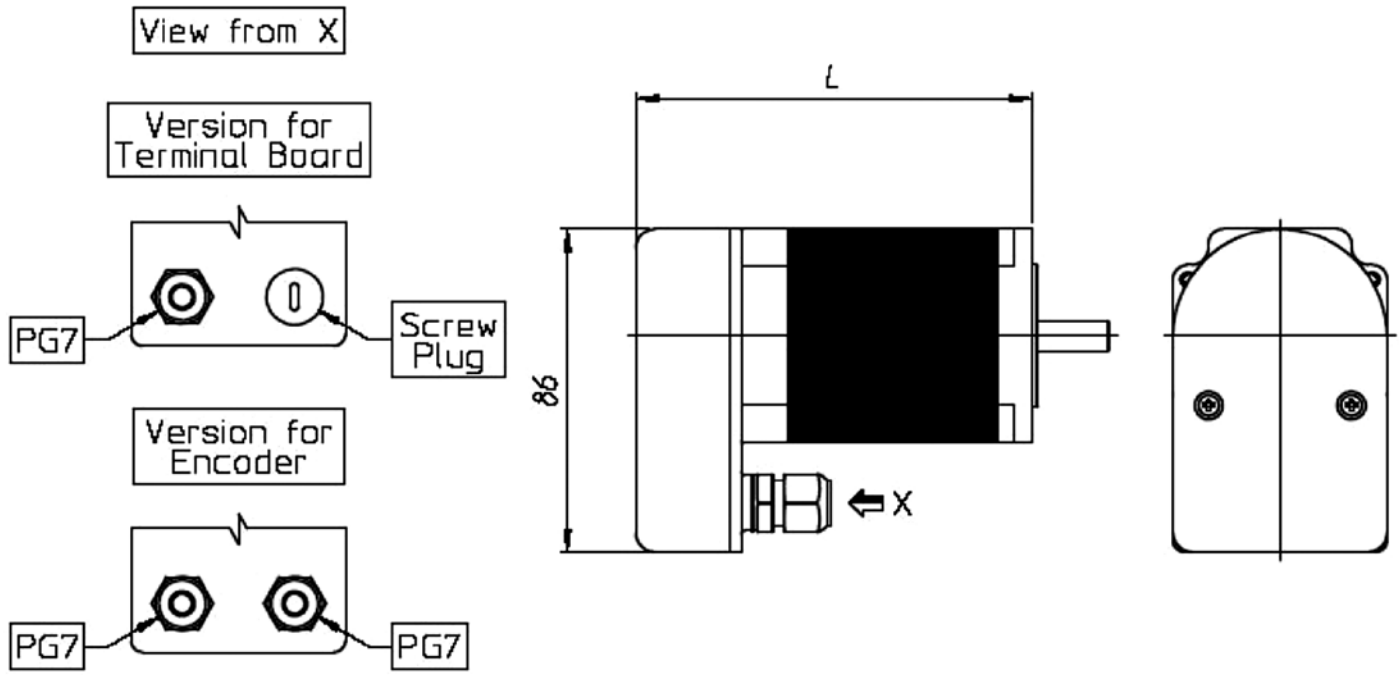

| Size | L max |
|------------|-----------|
| HS200 2216 | 69,00 mm |
| HS200 2221 | 83,00 mm |
| HS200 2231 | 107,00 mm |

| Size | L1 max |
|------------|-----------|
| HS200 2216 | 74,00 mm |
| HS200 2221 | 88,00 mm |
| HS200 2231 | 111,00 mm |

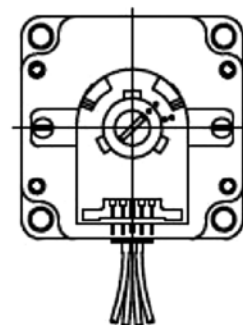
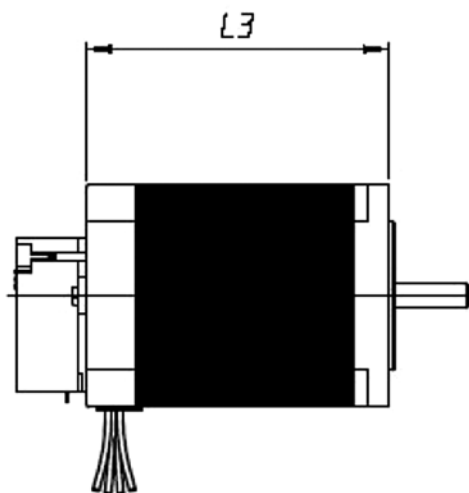
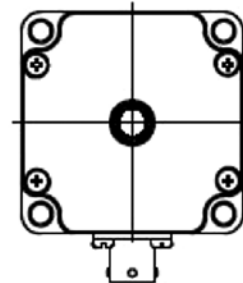
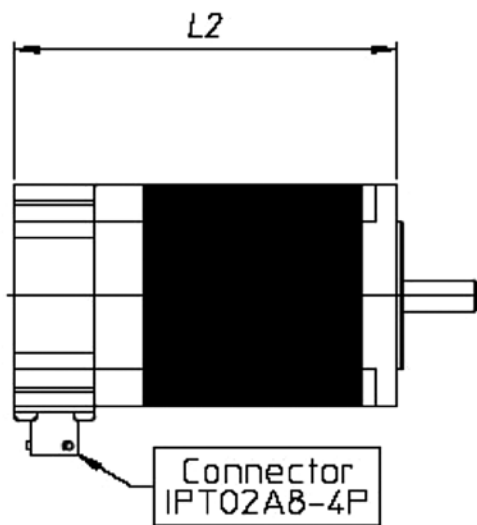

| Size | L2 max |
|------------|----------|
| HS200 2216 | 62,00 mm |
| HS200 2221 | 76,00 mm |
| HS200 2231 | 99,00 mm |

| Size | L3 max |
|------------|----------|
| HS200 2216 | 41,00 mm |
| HS200 2221 | 55,00 mm |
| HS200 2231 | 78,50 mm |

CUSTOMIZATIONS / OPTIONS SIZE 34

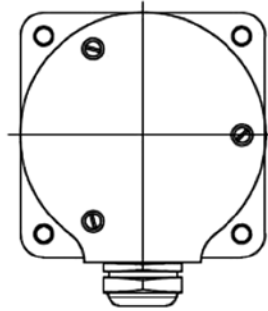
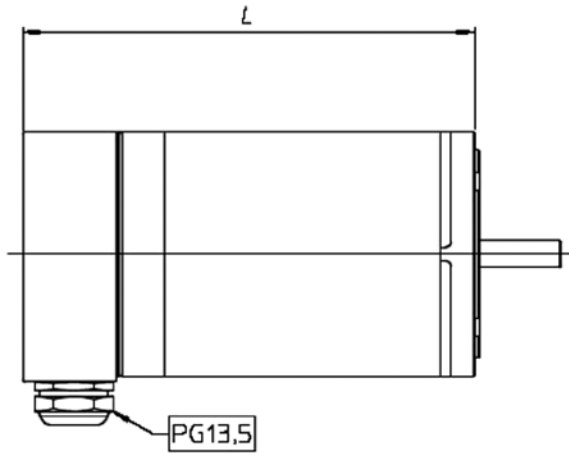

| Size | L max |
|------------|-----------|
| HN200 3426 | 101,10 mm |
| HN200 3438 | 128,10 mm |
| HN200 3451 | 159,10 mm |

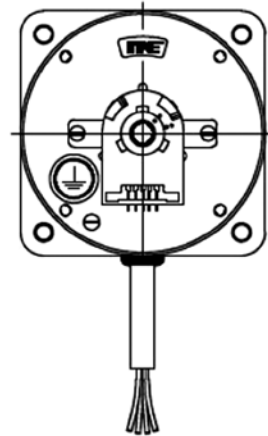
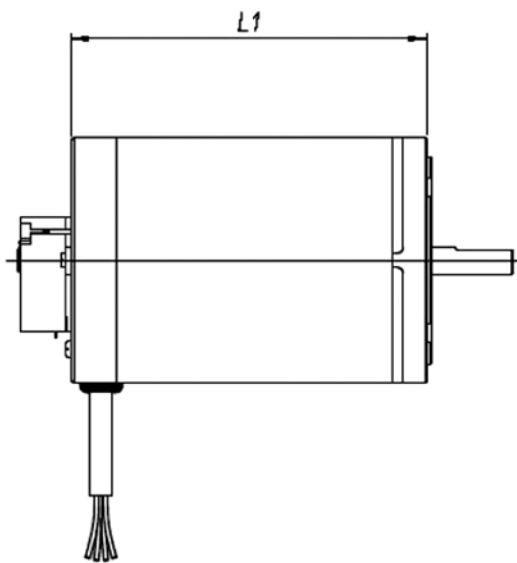

| Size | L1 max |
|------------|-----------|
| HN200 3426 | 67,00 mm |
| HN200 3438 | 94,00 mm |
| HN200 3451 | 125,00 mm |

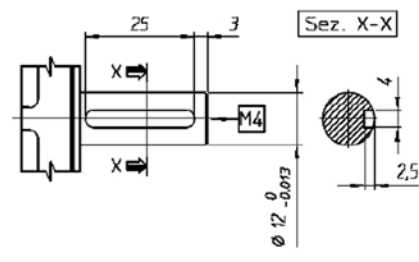
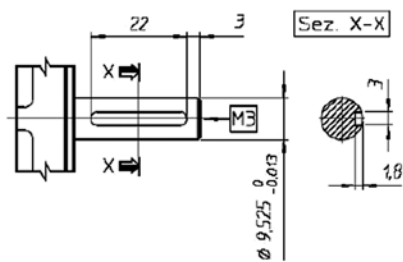
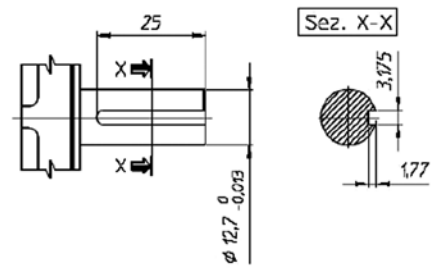
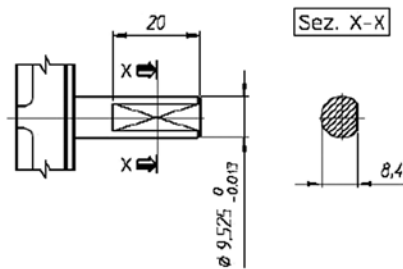

CUSTOMIZATIONS / OPTIONS SIZE 34

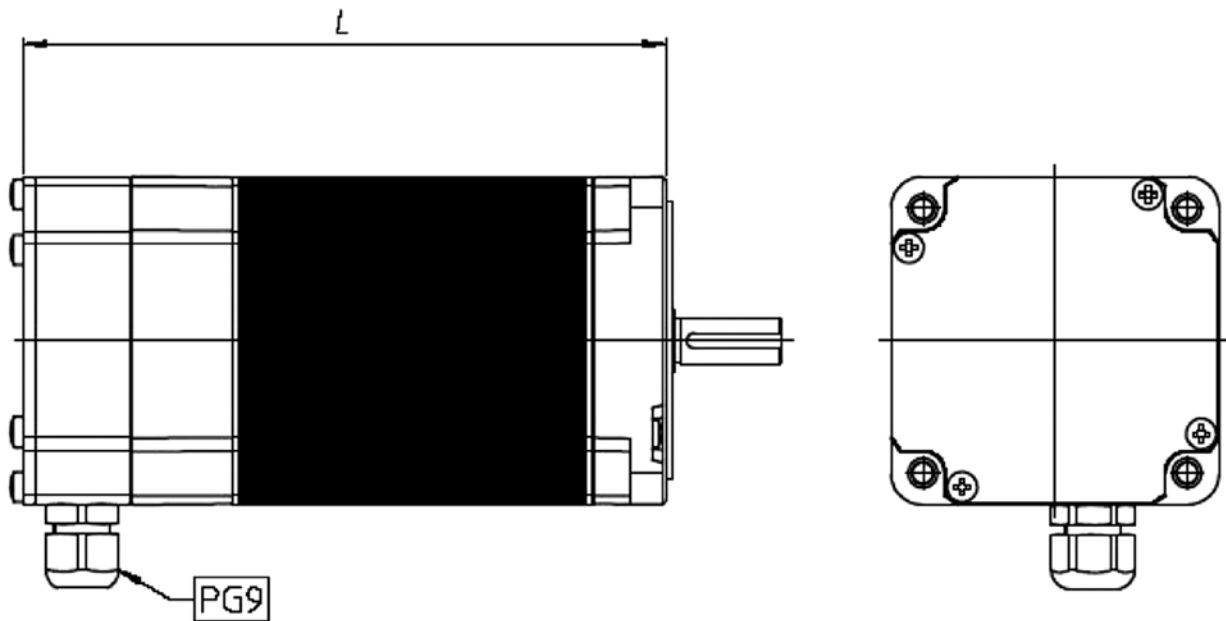

| Size | L max |
|------------|-----------|
| HS200 3437 | 125,00 mm |
| HS200 3448 | 153,00 mm |
| HS200 3455 | 171,00 mm |

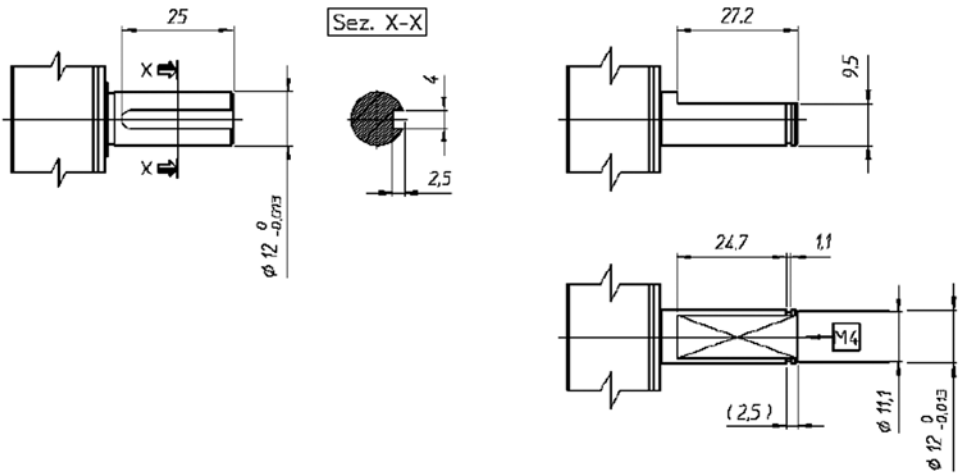

CONNECTION DIAGRAMS

BIPOLAR

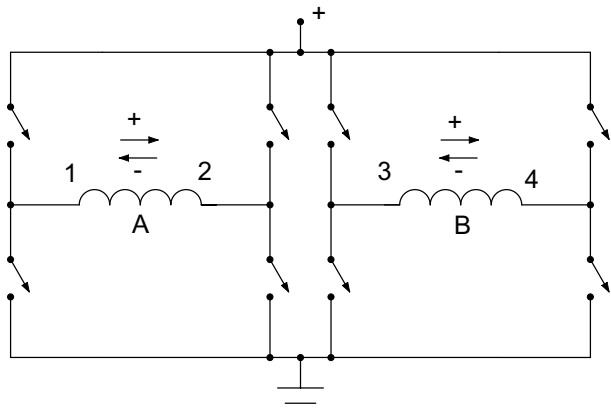

UNIPOLAR

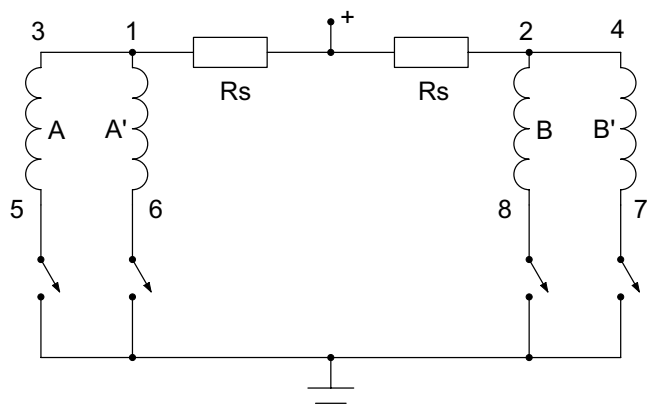

BIPOLAR (PARALLEL)

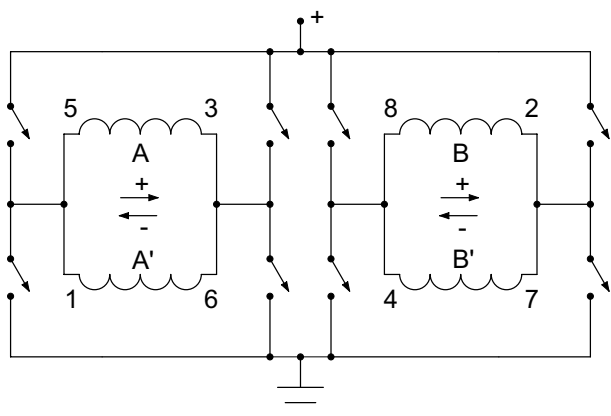

BIPOLAR (SERIES)

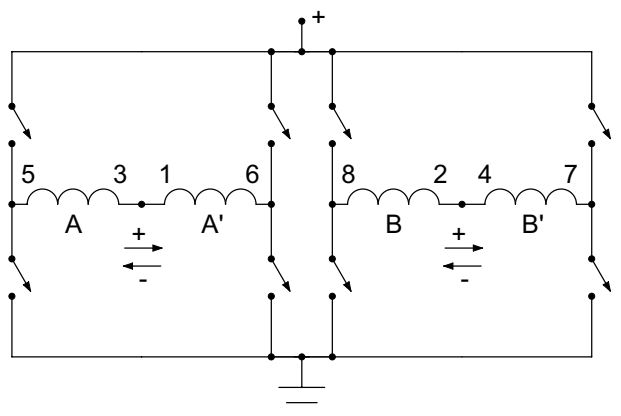

STEP SEQUENCES

FULL STEP OPERATION

| One Phase On | | | | |
|--------------|---|----|---|---------|
| Unipolar | | | | Bipolar |
| | A | A' | B | B' |
| 1 | + | 0 | 0 | 0 |
| 2 | 0 | 0 | + | 0 |
| 3 | 0 | + | 0 | 0 |
| 4 | 0 | 0 | 0 | + |
| 1 | + | 0 | 0 | 0 |

| Two Phases On | | | | |
|---------------|---|----|---|---------|
| Unipolar | | | | Bipolar |
| | A | A' | B | B' |
| 1 | + | 0 | 0 | + |
| 2 | + | 0 | + | 0 |
| 3 | 0 | + | + | 0 |
| 4 | 0 | + | 0 | + |
| 1 | + | 0 | 0 | + |

HALF STEP OPERATION

| Unipolar | | | | | Bipolar | | |
|----------|---|----|---|----|---------|---|---|
| | A | A' | B | B' | | A | B |
| 1 | + | 0 | 0 | + | 1 | + | + |
| 2 | + | 0 | 0 | 0 | 2 | 0 | + |
| 3 | + | 0 | + | 0 | 3 | - | + |
| 4 | 0 | 0 | + | 0 | 4 | - | 0 |
| 5 | 0 | + | + | 0 | 5 | - | - |
| 6 | 0 | + | 0 | 0 | 6 | 0 | - |
| 7 | 0 | + | 0 | + | 7 | + | - |
| 8 | 0 | 0 | 0 | + | 8 | + | 0 |
| 1 | + | 0 | 0 | + | 1 | + | + |

NOTE: Following the above steps in sequential order results in clockwise rotation of the shaft when viewed from the mounting end. Reversing the sequence results in counter-clockwise rotation.

AMETEK EUROPE

Stepper motors

Marketing & Technical Department

Via De Gasperi 18/a, 26010 Ripalta Cremasca (CR)

Tel. (+39) 0373 210305 Fax (+39) 0373 210295

Production plant:

Ametek Elektromotory s.r.o.

Českoskalická 15, 547 01 Náchod

Czech Republic

Tel. (+420) 494 943041 Fax (+420) 494 943 049

Distributore per L'Italia

PAMOCO S.p.A.

Via Riccardo Lombardi, 20153 Milano

Tel. (+39) 02 3450091 Fax (+39) 02 33104342

E-mail: info@pamoco.it

AMETEK Inc.

is a leading global manufacturer of electronic instruments and electromechanical devices with annualized sales of \$2.9 billions.



AMETEK has approximately 11,600 colleagues working at more than 100 manufacturing facilities and more than 100 sales and service centers in the United States and around the world.

AMETEK EUROPE

Stepper motors

Marketing & Technical Department
Via De Gasperi 18/a, 26010 Ripalta Cremasca (CR)
Tel. (+39) 0373 210305 Fax (+39) 0373 210295
infosteppers@ametek.it