

Version:1.04

SPECIFICATION

HTA050XSG-OR

Customer Approved

Customer _____

Date _____

By _____

Date: 2012.03.07

All information is subject to change without notice .Please confirm the sales representation before starting to design your system.

CONTENTS

General Description.....	2
Features	2
Applications	2
Driving Board Function Block	3
Application Schematic Diagrams	4
Electronic Characteristics.....	5
Connector Pin Definition.....	6-7
Outline Dimension	8

General Description:

This Color TFT LCD Driving Board apply to drive PVI's PA050XS1 PA050XU4, PA050XSG Color TFT LCD Panel, The Driving Board provides all the Needs to convert Composite video signal to the proper interface of LCD Panel .It can accept PAL and NTSC Video signal input.

Features:

- Fit PRIME VIEW PA050XS1& PA050XU4,PA050XSG TFT LCD
- Ultra Compac
- DC/DC DC/AC Video Decoder All In One
- PAL or NTSC Video input
- Up/Down Display Reverse
- Left/Right Display Reverse
- Single Operation Voltage 12V

Applications:

- Security
- Video Game
- Door Phone
- Video Phone
- Portable TV
- Instrument Display

Video input signal:

- Composite Video Signal 1.0Vp-p 75R

Work temperature:

- -20⁰C—+70⁰C

Storage temperature:

- -30⁰C—+80⁰C
-

Driving Board Function Block:

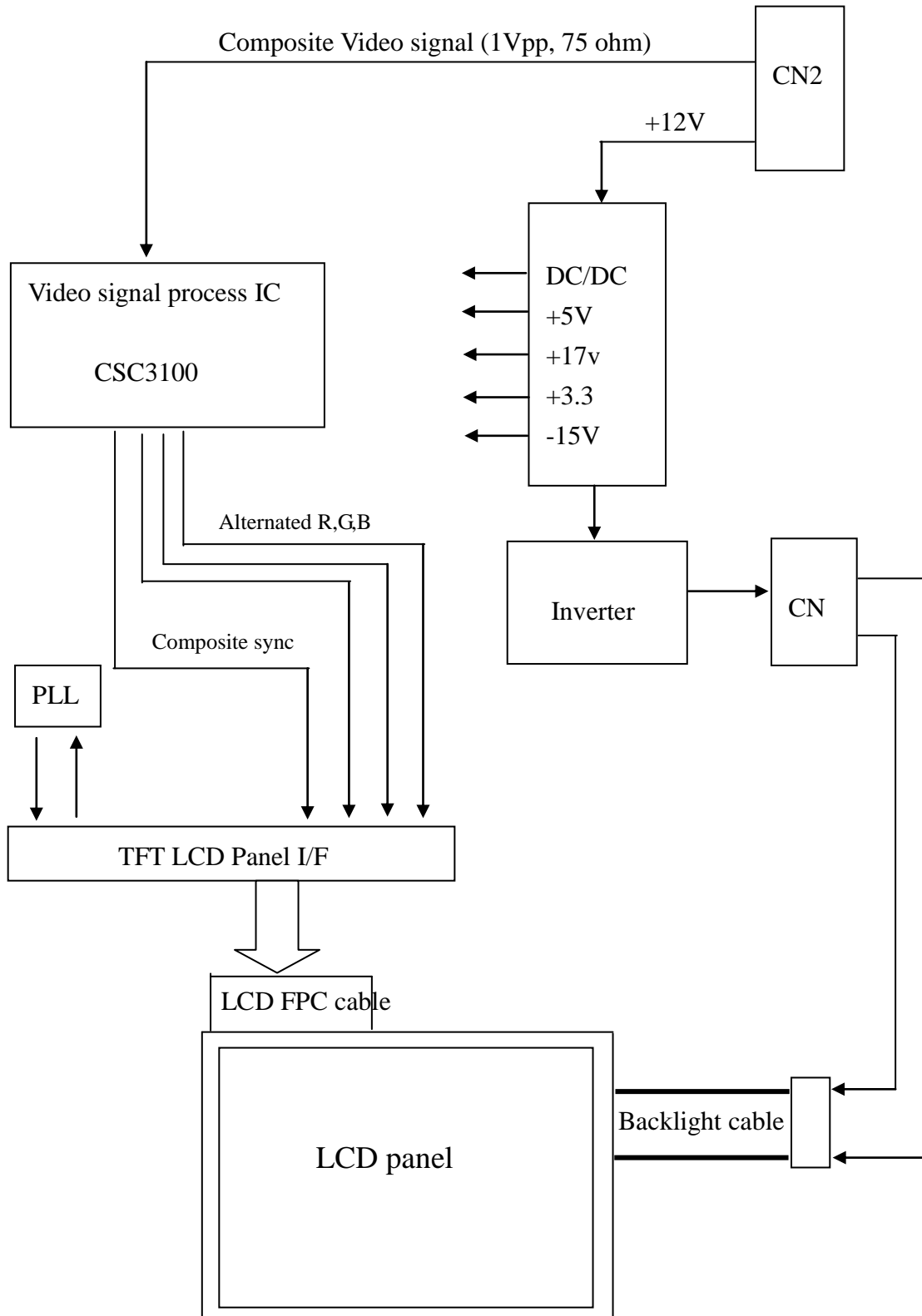

Application Schematic Diagrams

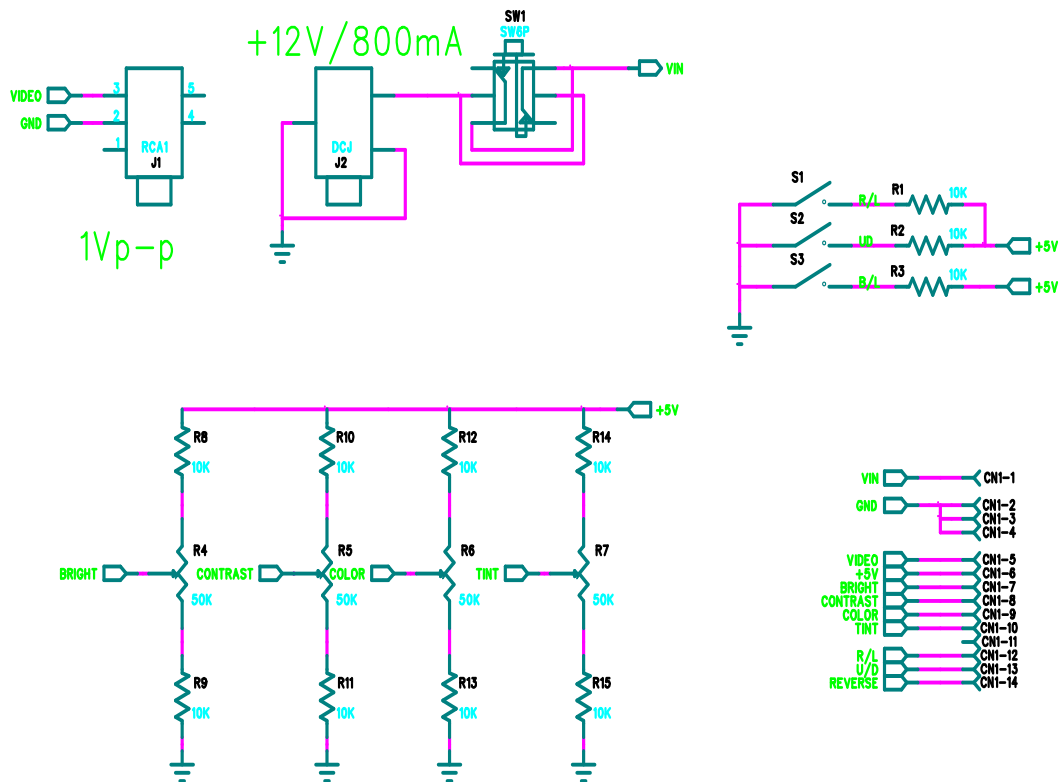

*The interface board supply power to the +5V pin of the CN2.
 You just supply DC12V voltage to the interface board

Electronic Characteristics (CN2)

Pin	Symbol	I/O	Conditions	Min	Typ	Max	Unit
5	Video	I	PAL or NTSC		1		V
1	V in I in P in	I	DC(+) DC (+12V)	10	12 550 6.6	14	V mA W
6	Vo Io	O	DC (+)		5 20		V mA
7	Bright(RGB)	I	DC (+)	2.1	2.3	2.5	V
8	Contrast	I	DC (+)	2.1	2.3	2.5	V
9	Color	I	DC (+)	1.3	1.5	1.7	V
10	Tint	I	DC (+)	1.7	1.8	1.9	V

Other VR Default Voltage

Pin	Symbol	I/O	Conditions	Min	Typ	Max	Unit
1	BRT	I	DC(+)	2.1	2.3	2.5	V
2	PIC	I	DC(+)	1.3	1.5	1.7	V

Input / Output Connector

1) CN2: Power & Video Input Connector

Pin No. : 14 , Pitch : 1.25 mm, Molex 53398-1410 or compatibility

2) CN3: RGB... Input Connector

Pin No. : 9 , Pitch : 1.25 mm, Molex 53398-0910 or compatibility

3) CN1: LCD Signal Output Connector

FPC Down Connector, 30 Pins , Pitch : 0.5 mm

4) CNH1: Backlight High Voltage Connector

Pin No. : 2 , Pitch : 3.5 mm JST BHSR-02VS-1 or compatibility

Connector Pin Definition

CN2 pin definition

No.	Pin Name	I/O	Pin description	Remark
1	Vin	I	+12V power input	
2	GND	I	Power ground	
3	GND	I	Power ground	
4	GND	I	Video signal ground	
5	Video	I	Composite video signal input	
6	+5V	O	For pin7/8/9/10 control purpose	
7	Brightness	I	Brightness control voltage input	
8	Contrast	I	Contrast control voltage input	
9	Color	I	Color control voltage input	
10	Tint	I	Tint control voltage input	
11	ON/OFF	I	ON/OFF (Default On)	NOTE 4
12	R/L	I	Picture left/right inverse control	NOTE 1
13	U/D	I	Picture up/down inverse control	NOTE 2
14	DIMMER	I	Dimmer (Default Nc)	NOTE 5

CN3 pin definition

No.	Pin Name	I/O	Pin description	Remark
1	Rin	I	Red signal input	
2	Gin	I	Green signal input	
3	Bin	I	Blue signal input	
4	SW	I	Switch (Video/RGB Select)	NOTE 3
5	SYNC IN	I	SYNC Input	
6	SYNC OUT	O	SYNC Output	
7	/HSYNC OUT	O	Reverse HSYNC Output	
8	/VSYNC OUT	O	Reverse VSYNC Output	
9	GND	I	Power Ground	

(1) CNH1 pin definition

No.	Pin Name	I/O		Remark
1	HV	O	Lamp driving terminal (high voltage)	
2	LV	O	Lamp driving terminal (low voltage)	

(2) CN1 pin definition

Meet PA050XS1 PA050XU4,PA050XSG input definition

Note 1:

R/L = Hi (+5V) for shift right, Low (GND) for shift left

Note 2:

U/D = Hi (+5V) for down, Low (GND) for up

Note 3:

VIDEO = Low, High (+5v) for RGB INPUT

Note 4: On/Off Function.

On/OFF= Hi (+5V) for On, Low (GND) for Off

Note 5: Dimmer Function

Voltage	0 V	1 V	2 V	3.5 V
Brightness	350 nit	280 nit	200 nit	100 nit

Note: highlights that the values are subject to change based on general character of the transformer

Default states:

- 1) Support video signal input
- 2) support Bright 、 Contrast 、 Color and Tint adjustable
- 3) Composite Sync input and could switch to RGB input
- 4) Support OSD input mode (RGB input and HSY/VSY output)

If need support S-video input, the followed operation is needed:

- 1) Open R59 (1K ohm resistor)
- 2) Solder RB1 (75ohm resistor)
- 3) Solder C64 (0.1uF capacitor)
- 4) Open RB2 (0ohm resistor)

If the analog video signal is RGB, the composite synchronization signal is needed.

Outline Dimension

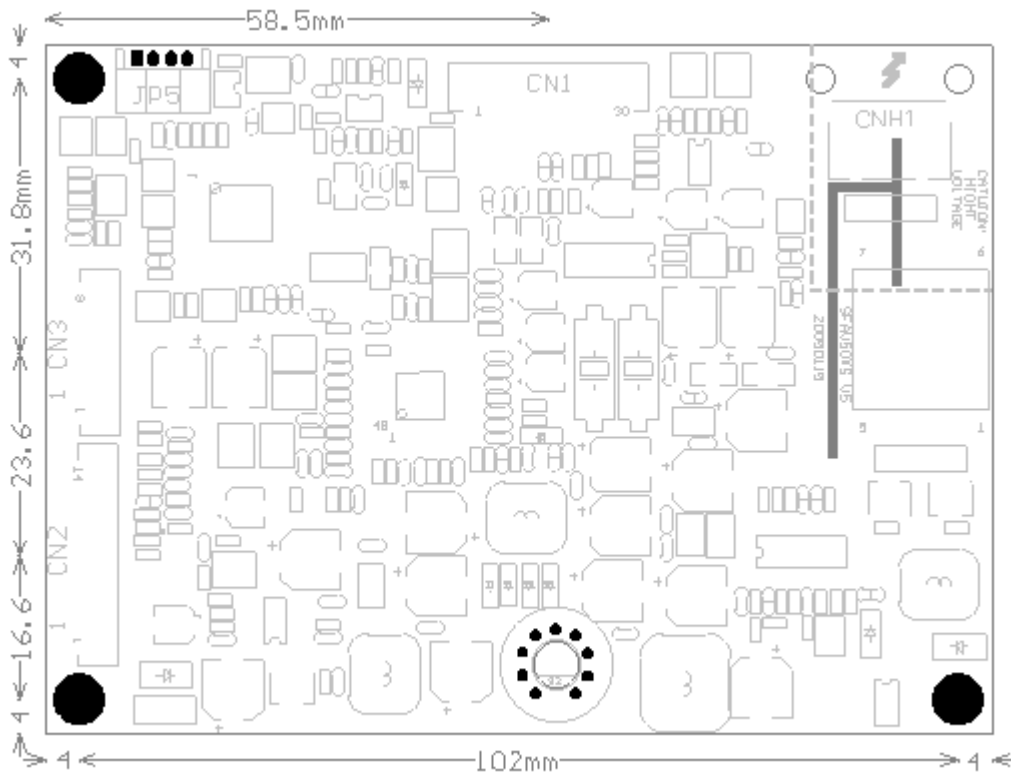

Description:

Outline: 110.0*80.0*10.1mm

Top Layer High (Max): 8.5mm

Board thickness: 1.6mm

6 Screws: M3.0

Weight: 0.05kg