

**PLEASE CHECK WWW.MOLEX.COM FOR LATEST PART INFORMATION**

**Part Number:** [0015477572](#)  
**Status:** **Active**  
**Description:** 2.54mm (.100") Pitch C-Grid® Header, Through Hole, Dual Row, Vertical, High Temperature, Shrouded, with Peg, 72 Circuits, Tin (Sn) Plating

**Documents:**

[3D Model](#) [Product Specification PS-70567 \(PDF\)](#)  
[Drawing \(PDF\)](#) [RoHS Certificate of Compliance \(PDF\)](#)

**Agency Certification**

CSA LR19980  
 UL E29179

**General**

Product Family PCB Headers  
 Series [70568](#)  
 Application Wire-to-Board  
 Product Name C-Grid®

**Physical**

Breakaway No  
 Circuits (Loaded) 72  
 Color - Resin Black  
 First Mate / Last Break No  
 Flammability 94V-0  
 Glow-Wire Compliant No  
 Guide to Mating Part No  
 Keying to Mating Part None  
 Lock to Mating Part Yes  
 Material - Metal Brass, Phosphor Bronze  
 Material - Plating Mating Tin  
 Material - Plating Termination Tin  
 Material - Resin High Temperature Thermoplastic  
 Number of Rows 2  
 Orientation Vertical  
 PC Tail Length (in) 0.130 In  
 PC Tail Length (mm) 3.30 mm  
 PCB Locator No  
 PCB Retention Yes  
 PCB Thickness Recommended (in) 0.093 In  
 PCB Thickness Recommended (mm) 2.40 mm  
 Packaging Type Tube  
 Pitch - Mating Interface (in) 0.100 In  
 Pitch - Mating Interface (mm) 2.54 mm  
 Pitch - Term. Interface (in) 0.100 In  
 Pitch - Term. Interface (mm) 2.54 mm  
 Plating min: Mating (µin) 150  
 Plating min: Mating (µm) 3.75  
 Plating min: Termination (µin) 150  
 Plating min: Termination (µm) 3.75  
 Polarized to Mating Part Yes  
 Polarized to PCB Yes  
 Shrouded Fully  
 Stackable No  
 Surface Mount Compatible (SMC) No  
 Temperature Range - Operating -55°C to +105°C

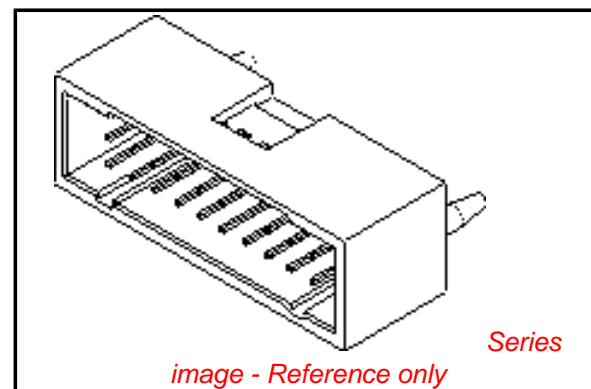

**EU RoHS**

**ELV and RoHS Compliant**  
**REACH SVHC Contains SVHC: No**  
**Halogen-Free Status**  
**Not Reviewed**

**China RoHS**



**Need more information on product environmental compliance?**

Email [productcompliance@molex.com](mailto:productcompliance@molex.com)  
 For a multiple part number RoHS Certificate of Compliance, [click here](#)

Please visit the [Contact Us](#) section for any non-product compliance questions.

**Search Parts in this Series**  
[70568Series](#)

Termination Interface: Style Through Hole

**Electrical**

Current - Maximum per Contact 2.5A  
Voltage - Maximum 250V

**Solder Process Data**

Duration at Max. Process Temperature (seconds) 5  
Lead-free Process Capability SMC & Wave Capable (TH only)  
Max. Cycles at Max. Process Temperature 1  
Process Temperature max. C 245

**Material Info**

Old Part Number A-70568-0034

**Reference - Drawing Numbers**

Product Specification PS-70567  
Sales Drawing SDA-70568-\*\*\*\*

This document was generated on 03/31/2010

**PLEASE CHECK [WWW.MOLEX.COM](http://WWW.MOLEX.COM) FOR LATEST PART INFORMATION**

STAND OFFS CAN BE EITHER ROUND OR SQUARE.

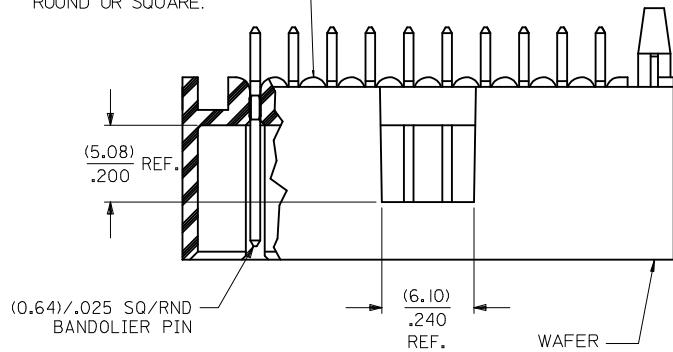

NOTES:

1. MATERIAL: WAFER - GLASS FILLED LIQUID CRYSTAL POLYMER, UL 94V-0, COLOR: BLACK, PIN: COPPER ALLOY.
2. PLATING: TIN  
 TIN(Sn) ALLOY OVER ENTIRE PIN: THICKNESS = (3.81 MICROMETER)/ 150 MICROINCH MINIMUM;  
 NICKEL (Ni) UNDERPLATE OVER ENTIRE PIN.  
 15 GOLD SELECTIVE GOLD (Au) IN THE CONTACT AREA: THICKNESS = (0.38 MICROMETER)/ 15 MICROINCH MINIMUM;  
 SELECTIVE TIN (Sn) ALLOY IN THE PC TAIL AREA: THICKNESS = (1.91 MICROMETER)/ 75 MICROINCH MINIMUM;  
 NICKEL (Ni) UNDERPLATE OVER ENTIRE PIN.  
 30 GOLD SELECTIVE GOLD (Au) IN THE CONTACT AREA: THICKNESS = (0.76 MICROMETER)/ 30 MICROINCH MINIMUM;  
 SELECTIVE TIN (Sn) ALLOY IN THE PC TAIL AREA: THICKNESS = (1.91 MICROMETER)/ 75 MICROINCH MINIMUM;  
 NICKEL (Ni) UNDERPLATE OVER ENTIRE PIN.  
 \* THE PRIMARY SHIPPING CARTON WILL BE LABELED "COMPLIANT TO RoHS DIRECTIVE 2002/95/EC AND ELV ANNEX II OF DIRECTIVE 2000/53/EC". CARTONS WITHOUT THIS LABEL MAY CONTAIN PRODUCT WITH LEAD.
3. PRODUCT SPECIFICATION: PS-70567.
4. PACKAGING: SEE CHARTS
5. PIN PUSHOUT FORCE: 4 LBS. MIN. IN DIRECTION INDICATED.
6. FOR ILLUSTRATION PURPOSES, 20 (DUAL 10) CIRCUIT SIZE IS SHOWN.
7. PINS MUST MEET SOLDERABILITY SPEC. SMS-152.  
 EXCEPT VOIDS ARE PERMISSIBLE AT BANDOLIER PIN FAYING SURFACE. (APPROX. (0.64)/.025 LNG X (0.15)/.006 WD. REF.) - 2 LOCATIONS
8. NO FEATURES WHICH RISE ABOVE THE PCB SURFACE ALLOWED IN THIS AREA.
9. THIS PART CONFORMS TO CLASS B REQUIREMENTS OF COSMETIC SPEC PS-45499-002.

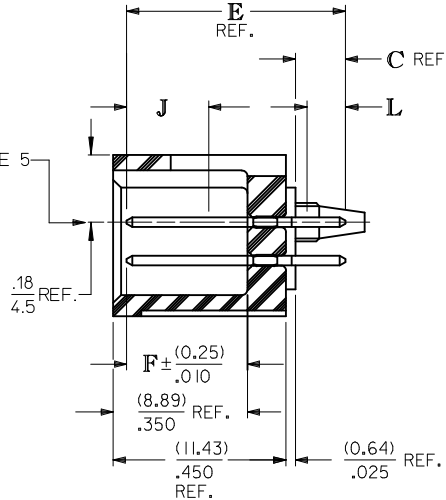
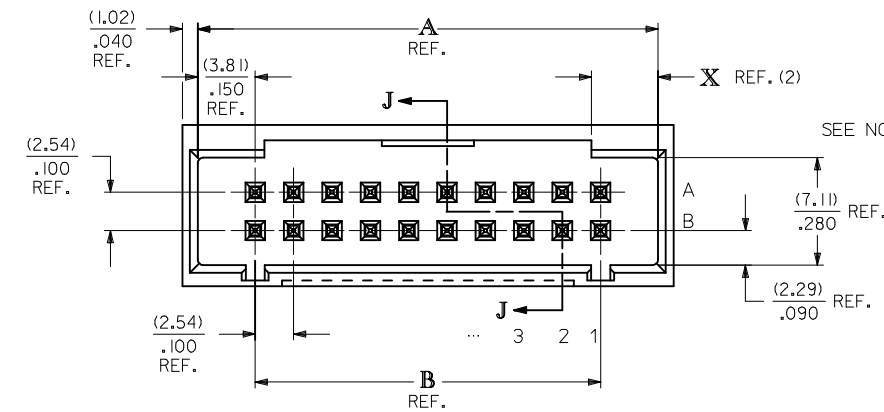

**SECTION J-J**

CKT. SIZE	DIM. A REF.		DIM. B REF.		DIM. X REF.	
	(MM)	INCH	(MM)	INCH	(MM)	INCH
6	(12.70)	.500	(5.08)	.200	(3.18)	.125
8	(15.24)	.600	(7.62)	.300	(4.42)	.174
10	(17.78)	.700	(10.16)	.400	(4.42)	.174
12	(20.32)	.800	(12.70)	.500	(4.42)	.174
14	(22.86)	.900	(15.24)	.600	(4.42)	.174
16	(25.40)	1.000	(17.78)	.700	(4.42)	.174
18	(27.94)	1.100	(20.32)	.800	(4.42)	.174
20	(30.48)	1.200	(22.86)	.900	(4.42)	.174
22	(33.02)	1.300	(25.40)	1.000	(4.42)	.174
24	(35.56)	1.400	(27.94)	1.100	(4.42)	.174
26	(38.10)	1.500	(30.48)	1.200	(4.42)	.174
28	(40.64)	1.600	(33.02)	1.300	(4.42)	.174
30	(43.18)	1.700	(35.56)	1.400	(4.42)	.174
32	(45.72)	1.800	(38.10)	1.500	(4.42)	.174
34	(48.26)	1.900	(40.64)	1.600	(4.42)	.174
36	(50.80)	2.000	(43.18)	1.700	(4.42)	.174
40	(55.88)	2.200	(48.26)	1.900	(4.42)	.174
42	(58.42)	2.300	(50.80)	2.000	(4.42)	.174
44	(60.96)	2.400	(53.34)	2.100	(4.42)	.174
46	(63.50)	2.500	(55.88)	2.200	(4.42)	.174
48	(66.04)	2.600	(58.42)	2.300	(4.42)	.174
50	(68.58)	2.700	(60.96)	2.400	(4.42)	.174
52	(71.12)	2.800	(63.50)	2.500	(4.42)	.174
54	(73.66)	2.900	(66.04)	2.600	(4.42)	.174
56	(76.20)	3.000	(68.58)	2.700	(4.42)	.174
58	(78.74)	3.100	(71.12)	2.800	(4.42)	.174
60	(81.28)	3.200	(73.66)	2.900	(4.42)	.174
62	(83.82)	3.300	(76.20)	3.000	(4.42)	.174
64	(86.36)	3.400	(78.74)	3.100	(4.42)	.174
66	(88.90)	3.500	(81.28)	3.200	(4.42)	.174
68	(91.44)	3.600	(83.82)	3.300	(4.42)	.174
70	(93.98)	3.700	(86.36)	3.400	(4.42)	.174
72	(96.52)	3.800	(88.90)	3.500	(4.42)	.174

2	G
1	H
SHT	REV

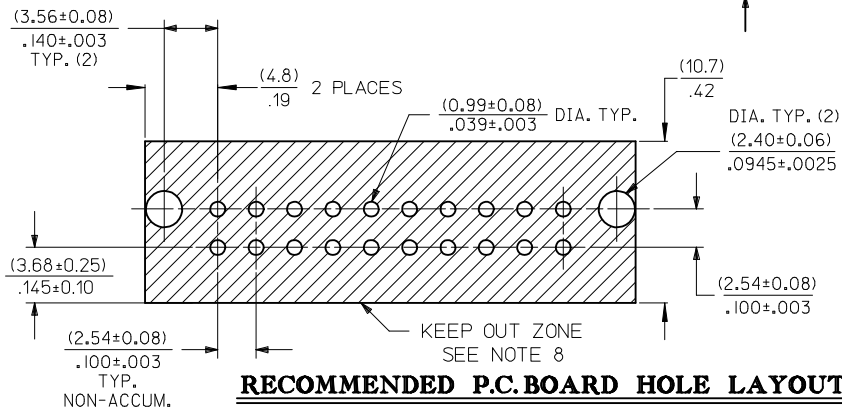
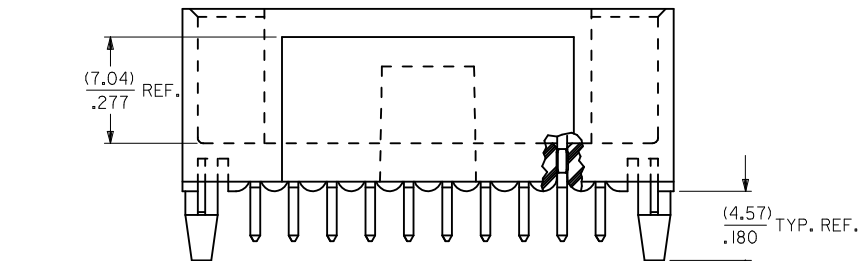

**RECOMMENDED P.C. BOARD HOLE LAYOUT**

MODIFIED NOTES	QUALITY SYMBOLS
EC NO: UCP2009-0336	▽=0
DRW: JALOSTEIER 2008/09/23	▽=0
CHKD: JEBEL 2008/09/24	
APPR: FSMITH 2008/09/25	
DESCRIPTION	
REV	

GENERAL TOLERANCES (UNLESS SPECIFIED)	
mm	INCH
4 PLACES ± ---	± ---
3 PLACES ± ---	± .005
2 PLACES ± 0.13	± .01
1 PLACE ± 0.25	± ---
ANGULAR ± 1/2°	
DRAFT WHERE APPLICABLE MUST REMAIN WITHIN DIMENSIONS	

DIMENSION STYLE	
MM/IN	
DRAWN BY	DATE
SMR	1993/11/10
CHECKED BY	DATE
SMR	1993/11/10
APPROVED BY	DATE
MATERIAL NO.	
SEE TABLE	
SIZE	
C	

SCALE	DESIGN UNITS	THIRD ANGLE PROJECTION
4:1	INCH	☉
TITLE		
SALES ASSY - DUAL ROW SHROUDED WAFER/HI TEMP .25SQ/RND PINS .100 GRID		
MOLEX INCORPORATED		
DOCUMENT NO.	SHEET NO.	
SDA-70568-****	1 OF 2	
THIS DRAWING CONTAINS INFORMATION THAT IS PROPRIETARY TO MOLEX INCORPORATED AND SHOULD NOT BE USED WITHOUT WRITTEN PERMISSION		

