

DELPHI SERIES



FEATURES

- ◆ High Efficiency: 96.8% @9.6V/50A
- ◆ Standard footprint: 58.4 x 36.8 x12.3mm (2.30"x1.45"x0.48")
- ◆ Industry standard pinout
- ◆ Input OVP, UVLO; output OCP and OTP
- ◆ 1500V isolation
- ◆ Basic insulation
- ◆ Monotonic startup into normal load and pre-bias loads
- ◆ No minimum load required
- ◆ Constant 500W output power
- ◆ Parallelable for higher power output
- ◆ ISO 9001, TL 9000, ISO 14001, QS9000, OHSAS18001 certified manufacturing facility
- ◆ UL/cUL 60950 (US & Canada), and TUV (EN60950) pending
- ◆ CE mark Pending

Delphi Series Q48SB, 500W Bus Converter DC/DC Power Modules: 48V in, 9.6V/55A out

The Delphi Series Q48SB, 48V input, single output, quarter brick, 500W bus converter is the latest offering from a world leader in power systems technology and manufacturing -- Delta Electronics, Inc. This product family supports intermediate bus architectures and powers multiple downstream non-isolated point-of-load (POL) converters. The Q48SB9R6 (5:1) operates from a nominal 48V input and provides up to 500W of power or up to 63A (@ 38Vin) of output current in an industry standard quarter brick footprint. The Q48SB 5:1 bus converter operates with 500W constant output power, hence when input voltage drops, the output current will increase accordingly. Typical efficiency for the 9.6V/50A output is 96.8%. With optimized component placement, creative design topology, and numerous patented technologies, the Q48SB bus converter delivers outstanding electrical and thermal performance. An optional heatsink is available for harsh thermal requirements.

OPTIONS

- ◆ Positive On/Off logic
- ◆ Heatspreader available for extended operation
- ◆ Latch mode output OCP and OTP

APPLICATIONS

- ◆ Datacom / Networking
- ◆ Wireless Networks
- ◆ Optical Network Equipment
- ◆ Server and Data Storage
- ◆ Industrial/Testing Equipment

TECHNICAL SPECIFICATIONS

($T_A=25^{\circ}\text{C}$, airflow rate=300 LFM, $V_{in}=48\text{Vdc}$, nominal V_{out} unless otherwise noted.)

PARAMETER	NOTES and CONDITIONS	Q48SB9R650NRFA			
		Min.	Typ.	Max.	Units
ABSOLUTE MAXIMUM RATINGS					
Input Voltage					
Continuous				57	Vdc
Operating Temperature	Refer to Fig.17 for the measuring point	-40		124	$^{\circ}\text{C}$
Storage Temperature		-55		125	$^{\circ}\text{C}$
Input/Output Isolation Voltage				1500	Vdc
INPUT CHARACTERISTICS					
Operating Input Voltage		36	48	57	Vdc
Input Under-Voltage Lockout					
Turn-On Voltage Threshold		32.5	34	35.5	Vdc
Turn-Off Voltage Threshold		30.5	32	33.5	Vdc
Lockout Hysteresis Voltage			2		Vdc
Input Over-Voltage Lockout					
Turn-Off Voltage Threshold		59	60.5	62	Vdc
Turn-On Voltage Threshold		57	58.5	60	Vdc
Lockout Hysteresis Voltage			2		Vdc
Maximum Input Current	100% Load, 38V V_{in}			13.5	A
No-Load Input Current		80		200	mA
Off Converter Input Current			12	15	mA
Inrush Current(I^2t)	With 100uF external input capacitor			1	A^2s
Input Reflected-Ripple Current	P-P thru 12uH inductor, 5Hz to 20MHz		20	40	mA
Internal input filter component value	L/C		0.47/4.4		$\mu\text{H}/\mu\text{F}$
Recommend external input capacitor for system stability					
Capacitance		47	100		μF
ESR	100KHz -40 $^{\circ}\text{C}$ to 100 $^{\circ}\text{C}$	0.1	0.2		ohm
OUTPUT CHARACTERISTICS					
Output Voltage Set Point	$V_{in}=48\text{V}$, $I_o=\text{no load}$, $T_a=25^{\circ}\text{C}$		9.6		Vdc
Output Voltage Regulation					
Over Load	$I_o=I_{o,\text{min}}$ to $I_{o,\text{max}}$		400	600	mV
Over Line	$V_{in}=38\text{V}$ to 55V			3.8	V
Over Temperature	$T_c=-40^{\circ}\text{C}$ to 100°C			400	mV
Total Output Voltage Range	over sample load, line and temperature	6.8		11.5	V
Output Voltage Ripple and Noise	5Hz to 20MHz bandwidth				
Peak-to-Peak	Full Load, 1 μF ceramic, 10 μF tantalum		80	120	mV
RMS	Full Load, 1 μF ceramic, 10 μF tantalum		25	50	mV
Operating Output Power Range					
38V $\leq V_{in}\leq 42\text{V}$		0		480	W
42V $\leq V_{in}\leq 55\text{V}$		0		500	W
Output DC Power-Limit Inception	output voltage 10% lower				
38V $\leq V_{in}\leq 55\text{V}$			120%	130%	W
Current share accuracy (2 units in parallel)	% of rated output current			10	%
DYNAMIC CHARACTERISTICS					
Output Voltage Current Transient	48V, 10 μF Tan & 1 μF Ceramic load cap, 1A/ μs				
Positive Step Change in Output Current	50% $I_{o,\text{max}}$ to 75% $I_{o,\text{max}}$			300	mV
Negative Step Change in Output Current	75% $I_{o,\text{max}}$ to 50% $I_{o,\text{max}}$			300	mV
Settling Time (within 1% V_{out} nominal)				200	μs
Turn-On Transient					
Start-Up Time, From On/Off Control				35	ms
Start-Up Time, From Input				35	ms
Maximum Output Capacitance					
Single module operation	Start up with 20A Load			10000	μF
Single module operation	Start up with 55A Load			5000	μF
2 pcs Parallel module operation	Start up with 20A Load			10000	μF
2 pcs Parallel module operation	Start up with 110A Load			8000	μF
EFFICIENCY					
55A		95.4	96.4		%
50A		95.8	96.8		%
33A		95.8	96.8		%
ISOLATION CHARACTERISTICS					
Input to Output				1500	Vdc
Isolation Resistance		10			$\text{M}\Omega$
Isolation Capacitance			1000		pF
FEATURE CHARACTERISTICS					
Switching Frequency			130		kHz
ON/OFF Control for single module operation					
Negative Remote On/Off logic					
Logic Low (Module On)		-0.7		0.8	V
Logic High (Module Off)		2		18	V
Positive Remote On/Off logic					
Logic Low (Module Off)		-0.7		0.8	V
Logic High (Module On)		2		18	V
ON/OFF Current (for both remote on/off logic)	$I_{on/off}$ at $V_{on/off}=0.0\text{V}$		0.25	0.3	mA
Leakage Current (for both remote on/off logic)	Logic High, $V_{on/off}=15\text{V}$			50	μA
GENERAL SPECIFICATIONS					
MTBF	$I_o=80\%$ of $I_{o,\text{max}}$; $T_a=25^{\circ}\text{C}$; 300LFM airflow		TBD		M hours
Weight (open frame)			54		grams
Over-Temperature Shutdown	Refer to Fig.17 for the measuring point		129		$^{\circ}\text{C}$

ELECTRICAL CHARACTERISTICS CURVES

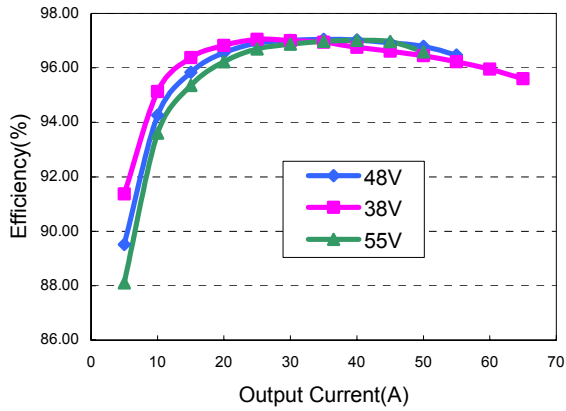

Figure 1: Efficiency vs. load current for minimum, nominal, and maximum input voltage at 25°C

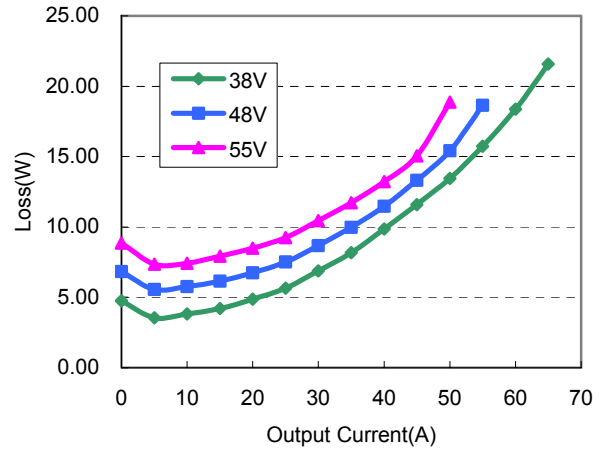

Figure 2: Power loss vs. load current for minimum, nominal, and maximum input voltage at 25°C.

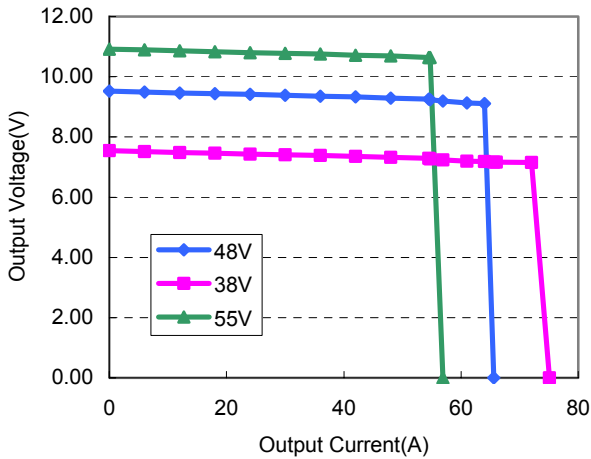

Figure 3: Output voltage regulation vs load current showing typical current limit curves and converter shutdown points for minimum, nominal, and maximum input voltage at room temperature.

ELECTRICAL CHARACTERISTICS CURVES

For Negative Remote On/Off Logic

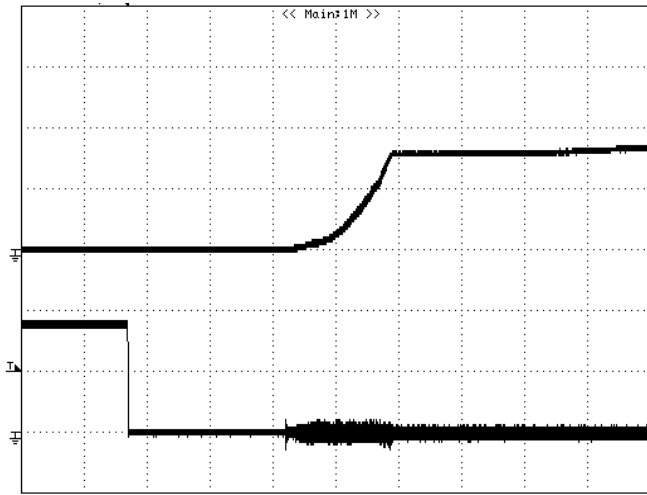

Figure 4: Turn-on transient at full rated load current (5 ms/div). Top Trace: Vout; 5V/div; Bottom Trace: ON/OFF input: 2V/div

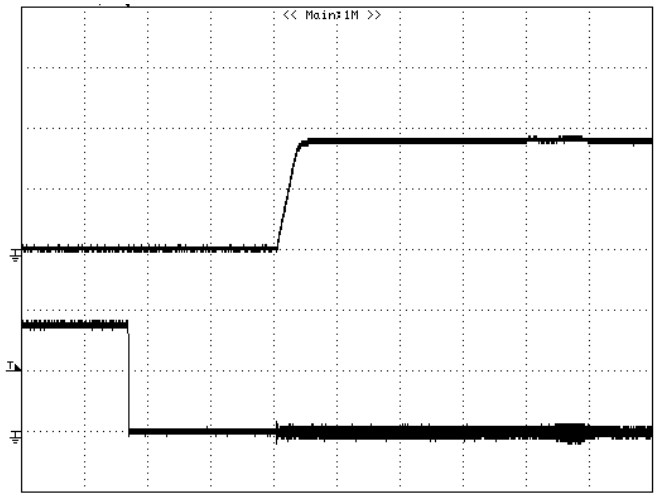

Figure 5: Turn-on transient at zero load current (5 ms/div). Top Trace: Vout: 5V/div; Bottom Trace: ON/OFF input: 2V/div

For Positive Remote On/Off Logic

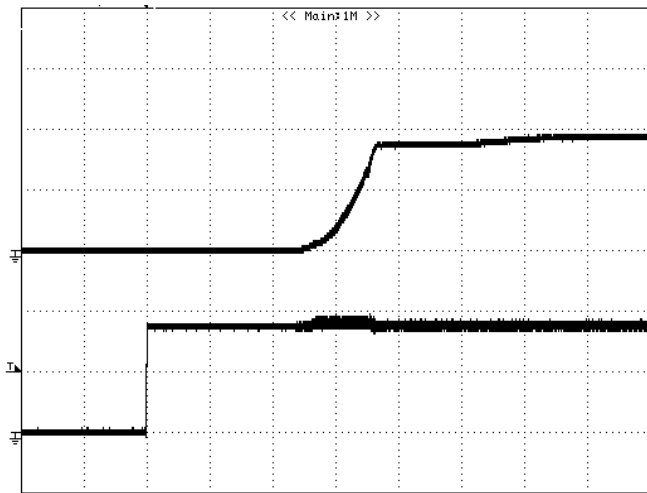

Figure 6: Turn-on transient at full rated load current (5 ms/div). Top Trace: Vout; 5V/div; Bottom Trace: ON/OFF input: 2V/div

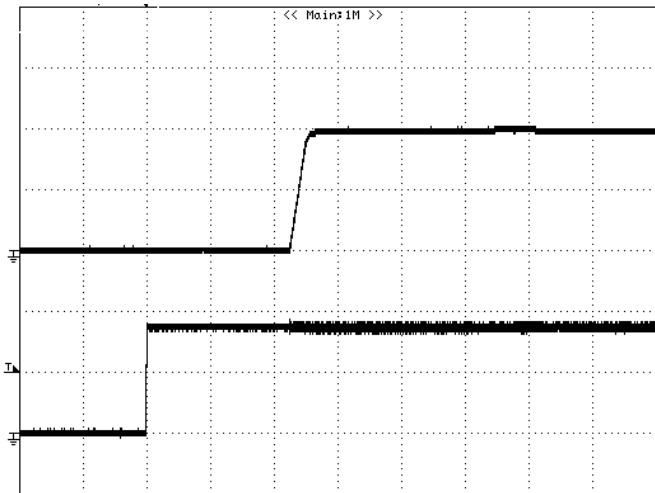

Figure 7: Turn-on transient at zero load current (5 ms/div). Top Trace: Vout: 5V/div; Bottom Trace: ON/OFF input: 2V/div

ELECTRICAL CHARACTERISTICS CURVES

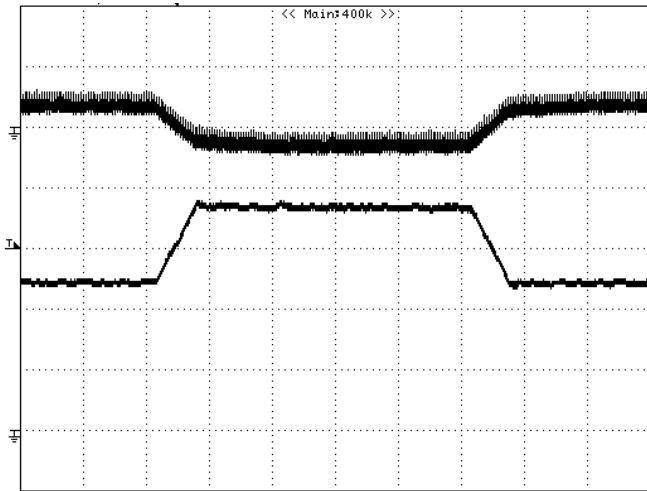

Figure 8: Output voltage response to step-change in load current (50%-75%-50% of $I_{o,max}$; $di/dt = 0.1A/\mu s$). Load cap: $10\mu F$, tantalum capacitor and $1\mu F$ ceramic capacitor. Top Trace: V_{out} (200mV/div, 200us/div), Bottom Trace: I_{out} (10A/div). Scope measurement should be made using a BNC cable (length shorter than 20 inches). Position the load between 51 mm to 76 mm (2 inches to 3 inches) from the module.

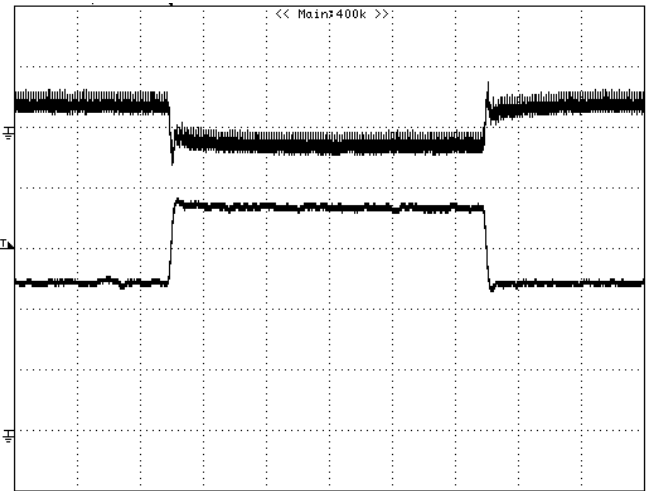

Figure 9: Output voltage response to step-change in load current (50%-75%-50% of $I_{o,max}$; $di/dt = 1A/\mu s$). Load cap: $10\mu F$, tantalum capacitor and $1\mu F$ ceramic capacitor. Top Trace: V_{out} (200mV/div, 200us/div), Bottom Trace: I_{out} (10A/div). Scope measurement should be made using a BNC cable (length shorter than 20 inches). Position the load between 51 mm to 76 mm (2 inches to 3 inches) from the module.

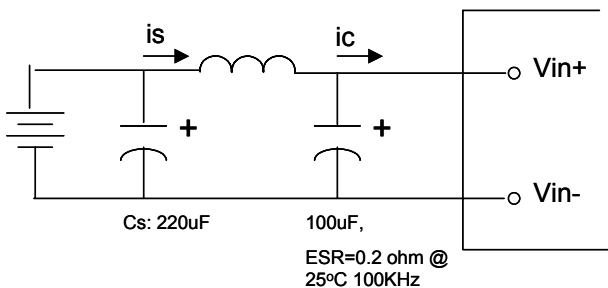

Figure 10: Test set-up diagram showing measurement points for Input Terminal Ripple Current and Input Reflected Ripple Current.

Note: Measured input reflected-ripple current with a simulated source Inductance (L_{TEST}) of $12\mu H$. Capacitor C_s offset possible battery impedance. Measure current as shown below

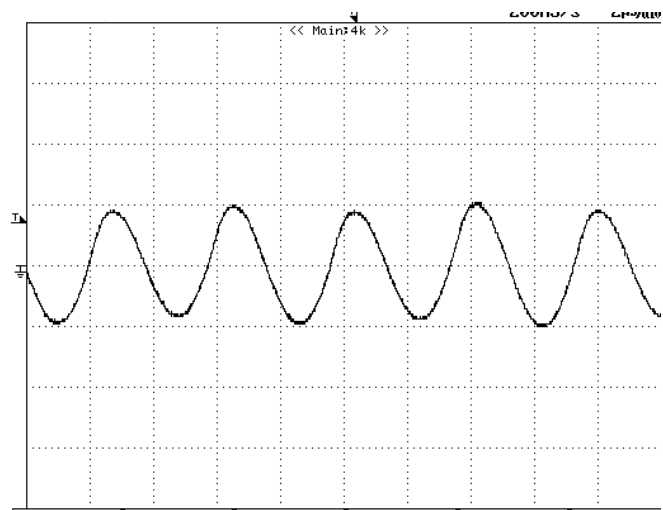

Figure 11: Input Terminal Ripple Current, i_c , at full rated output current and nominal input voltage with $12\mu H$ source impedance and $47\mu F$ electrolytic capacitor (1A/div, 2us/div).

ELECTRICAL CHARACTERISTICS CURVES

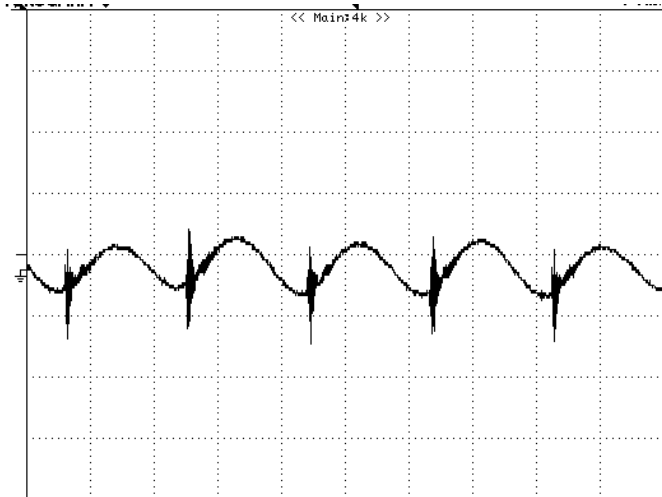

Figure 12: Input reflected ripple current, i_s , through a $12\mu\text{H}$ source inductor at nominal input voltage and rated load current (20 mA/div, 2µs/div).

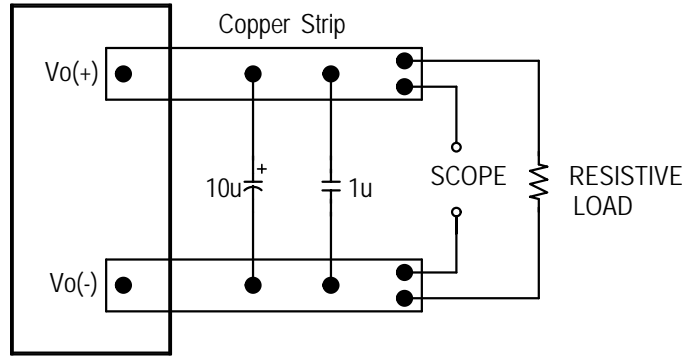

Figure 13: Output voltage noise and ripple measurement test setup.

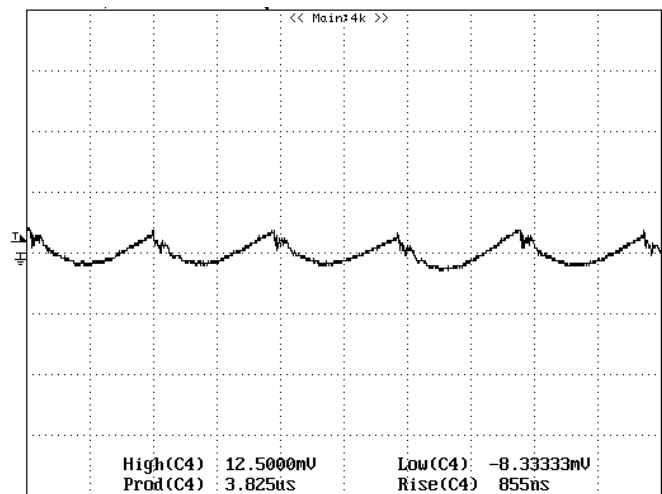

Figure 14: Output voltage ripple at nominal input voltage and rated load current (50 mV/div, 2µs/div). Load capacitance: $1\mu\text{F}$ ceramic capacitor and $10\mu\text{F}$ tantalum capacitor. Bandwidth: 20 MHz. Scope measurements should be made using a BNC cable (length shorter than 20 inches). Position the load between 51 mm to 76 mm (2 inches to 3 inches) from the module.

DESIGN CONSIDERATIONS

Input Source Impedance

The impedance of the input source connecting to the DC/DC power modules will interact with the modules and affect the stability. A low ac-impedance input source is recommended. If the source inductance is more than a few μH , we advise adding a typical 100 μF electrolytic capacitor (ESR > 0.1 Ω at 100 kHz, -40°C to 100°C.) mounted close to the input of the module to improve the stability.

Layout and EMC Considerations

Delta's DC/DC power modules are designed to operate in a wide variety of systems and applications. For design assistance with EMC compliance and related PWB layout issues, please contact Delta's technical support team. An external input filter module is available for easier EMC compliance design. Application notes to assist designers in addressing these issues are pending release.

Safety Considerations

The power module must be installed in compliance with the spacing and separation requirements of the end-user's safety agency standard, i.e., UL60950, CAN/CSA-C22.2 No. 60950-00 and EN60950: 2000 and IEC60950-1999, if the system in which the power module is to be used must meet safety agency requirements.

Basic insulation based on 75 Vdc input is provided between the input and output of the module for the purpose of applying insulation requirements when the input to this DC-to-DC converter is identified as TNV-2 or SELV. An additional evaluation is needed if the source is other than TNV-2 or SELV.

When the input source is SELV circuit, the power module meets SELV (safety extra-low voltage) requirements. If the input source is a hazardous voltage which is greater than 60 Vdc and less than or equal to 75 Vdc for the module's output to meet SELV requirements, all of the following must be met:

- The input source must be insulated from the ac mains by reinforced or double insulation.
- The input terminals of the module are not operator accessible.
- If the metal baseplate is grounded, one Vi pin and one Vo pin shall also be grounded.
- A SELV reliability test is conducted on the system where the module is used, in combination with the module, to ensure that under a single fault, hazardous voltage does not appear at the module's output.

When installed into a Class II equipment (without grounding), spacing consideration should be given to the end-use installation, as the spacing between the module and mounting surface have not been evaluated.

The power module has extra-low voltage (ELV) outputs when all inputs are ELV.

This power module is not internally fused. To achieve optimum safety and system protection, an input line fuse is highly recommended. The safety agencies require a normal-blow fuse with 50A maximum rating to be installed in the ungrounded lead. A lower rated fuse can be used based on the maximum inrush transient energy and maximum input current.

Soldering and Cleaning Considerations

Post solder cleaning is usually the final board assembly process before the board or system undergoes electrical testing. Inadequate cleaning and/or drying may lower the reliability of a power module and severely affect the finished circuit board assembly test. Adequate cleaning and/or drying is especially important for un-encapsulated and/or open frame type power modules. For assistance on appropriate soldering and cleaning procedures, please contact Delta's technical support team.

FEATURES DESCRIPTIONS

Over-Current Protection

The modules include an internal output over-current protection circuit, which will endure current limiting for an unlimited duration during output overload. If the output current exceeds the OCP set point, the modules will automatically shut down, and enter latch mode or hiccup mode, which is optional.

For hiccup mode, the module will try to restart after shutdown. If the overload condition still exists, the module will shut down again. This restart trial will continue until the overload condition is corrected.

For latch mode, the module will latch off once it shutdown. The latch is reset by either cycling the input power or by toggling the on/off signal for one second.

Over-Temperature Protection

The over-temperature protection consists of circuitry that provides protection from thermal damage. If the temperature exceeds the over-temperature threshold the module will shut down, and enter latch mode or auto-restart mode, which is optional.

For auto-restart mode, the module will monitor the module temperature after shutdown. Once the temperature is within the specification, the module will be auto-restart,

For latch mode, the module will latch off once it shutdown. Either cycling the input power or toggling the on/off signal for one second can reset the latch.

Remote On/Off

The remote on/off feature on the module can be either negative or positive logic. Negative logic turns the module on during a logic low and off during a logic high. Positive logic turns the modules on during a logic high and off during a logic low.

Remote on/off can be controlled by an external switch between the on/off terminal and the Vi(-) terminal. The switch can be an open collector or open drain.

For negative logic if the remote on/off feature is not used, please short the on/off pin to Vi(-). For positive logic if the remote on/off feature is not used, please leave the on/off pin to floating.

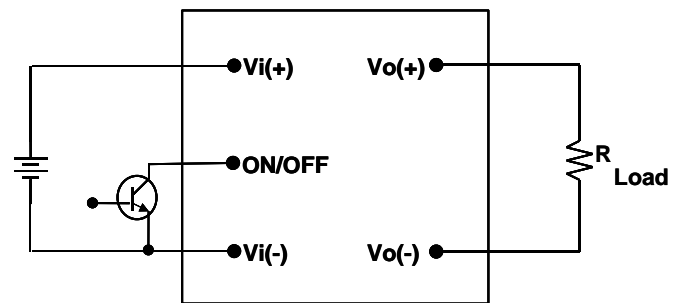

Figure 15: Remote on/off implementation

THERMAL CONSIDERATIONS

Thermal management is an important part of the system design. To ensure proper, reliable operation, sufficient cooling of the power module is needed over the entire temperature range of the module. Convection cooling is usually the dominant mode of heat transfer.

Hence, the choice of equipment to characterize the thermal performance of the power module is a wind tunnel.

Thermal Testing Setup

Delta's DC/DC power modules are characterized in heated vertical wind tunnels that simulate the thermal environments encountered in most electronics equipment. This type of equipment commonly uses vertically mounted circuit cards in cabinet racks in which the power modules are mounted.

The following figure shows the wind tunnel characterization setup. The power module is mounted on a test PWB and is vertically positioned within the wind tunnel. The space between the neighboring PWB and the top of the power module is constantly kept at 6.35mm (0.25").

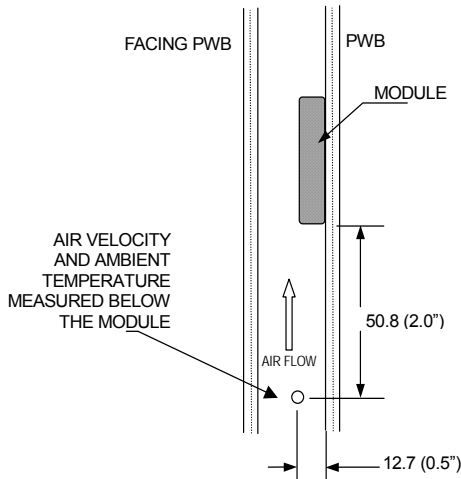

Note: Wind Tunnel Test Setup Figure Dimensions are in millimeters and (Inches)

Figure 16: Wind tunnel test setup

Thermal Derating

Heat can be removed by increasing airflow over the module. The module's maximum hot spot temperature is 124°C. To enhance system reliability, the power module should always be operated below the maximum operating temperature. If the temperature exceeds the maximum module temperature, reliability of the unit may be affected.

THERMAL CURVES

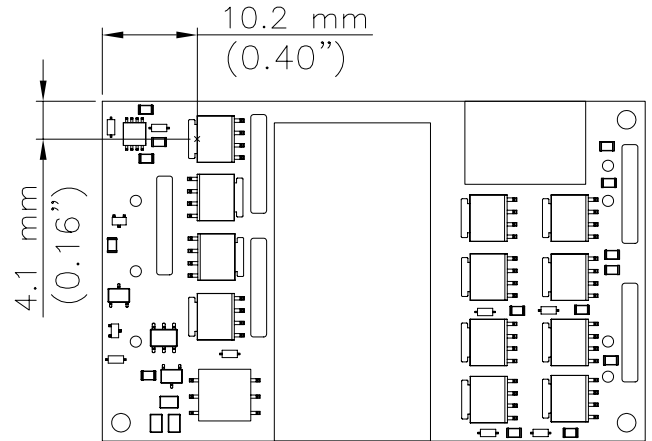

Figure 17: Hot spot temperature measured point
*The allowed maximum hot spot temperature is defined at 124°C

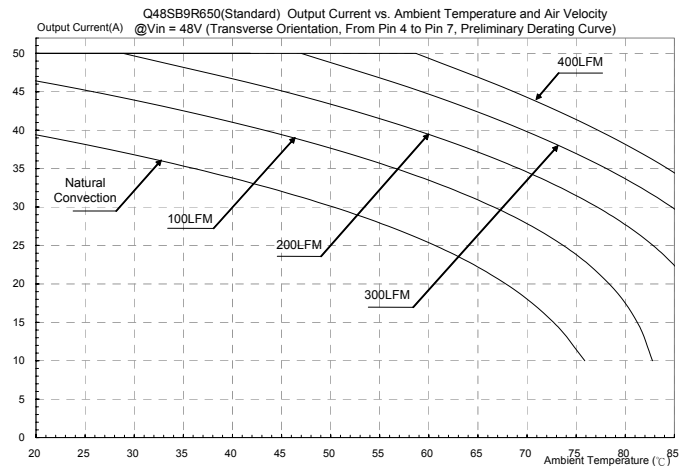
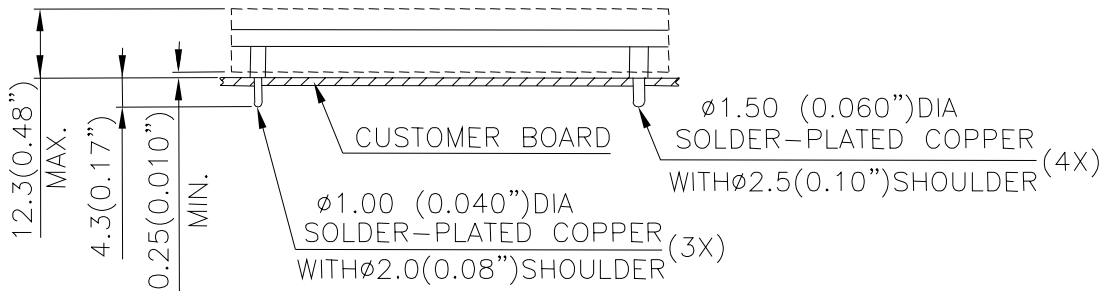
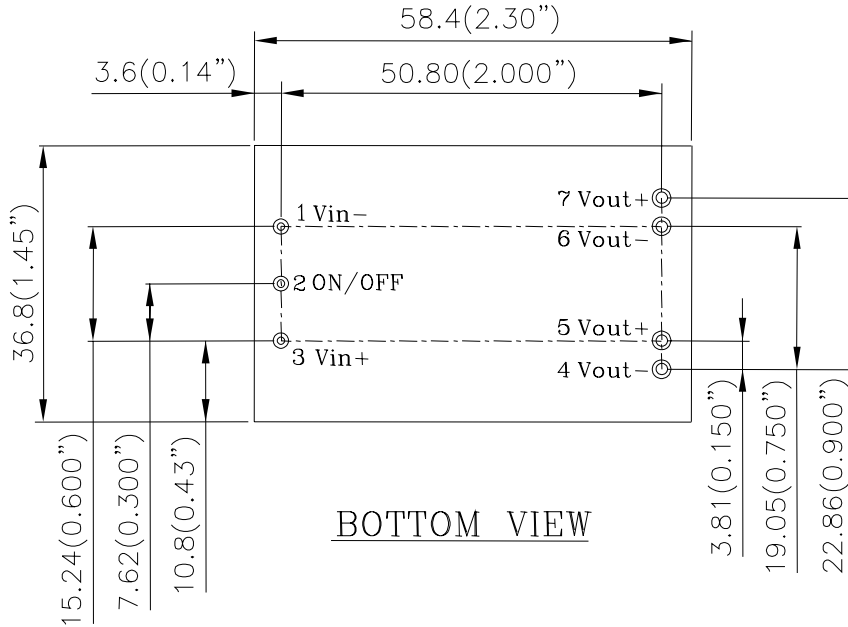

Figure 18: Output current vs. ambient temperature and air velocity @ $V_{in}=48V$ (Transverse orientation, from pin 4 to pin 7, preliminary derating curve, without heatspreader)

TBD

Figure 19: Output current vs. ambient temperature and air velocity @ $V_{in}=48V$ (Transverse Orientation, with heat spreader)

MECHANICAL DRAWING (WITHOUT HEATSPREADER)



NOTES:
 DIMENSIONS ARE IN MILLIMETERS AND (INCHES)
 TOLERANCES: X.Xmm \pm 0.5mm(X.XX in. \pm 0.02 in.)
 X.XXmm \pm 0.25mm(X.XXX in. \pm 0.010 in.)

<u>Pin No.</u>	<u>Name</u>	<u>Function</u>
1	-Vin	Negative input voltage
2	ON/OFF	Remote ON/OFF
3	+Vin	Positive input voltage
4	-Vout	Negative output voltage (optional)
5	+Vout	Positive output voltage
6	-Vout	Negative output voltage
7	+Vout	Positive output voltage (optional)

Pin Specification:

Pins 1-3 1.0mm (0.040") diameter
 Pins 4-7 1.5mm (0.060") diameter
 All pins are copper with Tin plating

MECHANICAL DRAWING (WITH HEAT SPREADER)

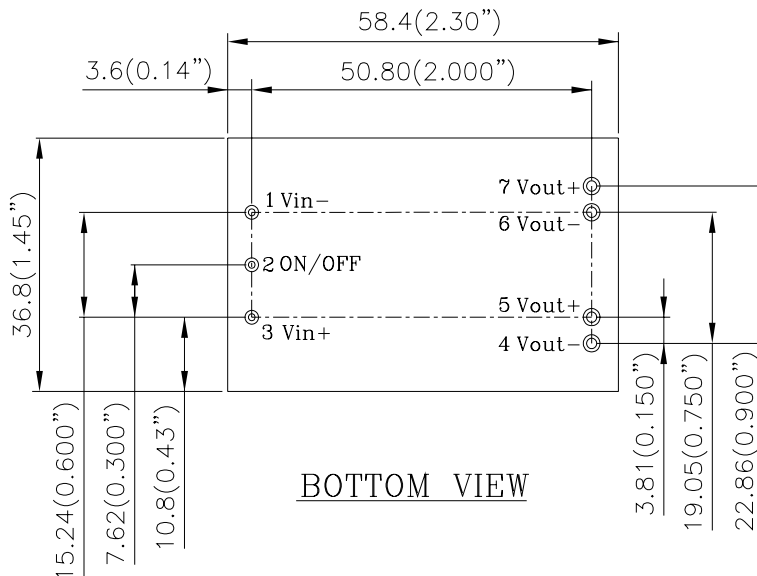
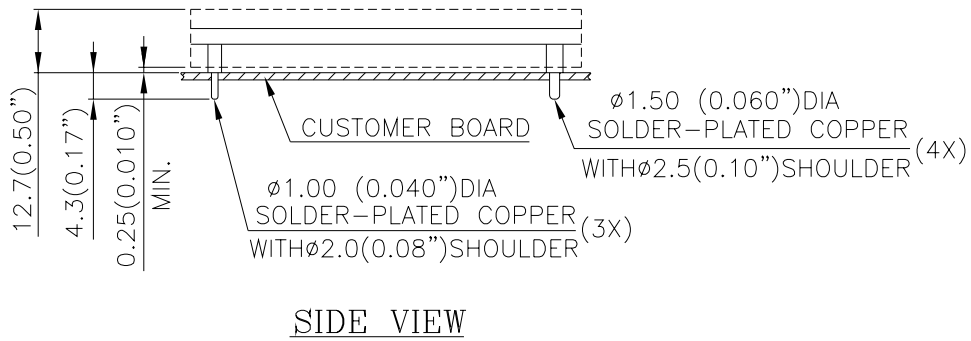
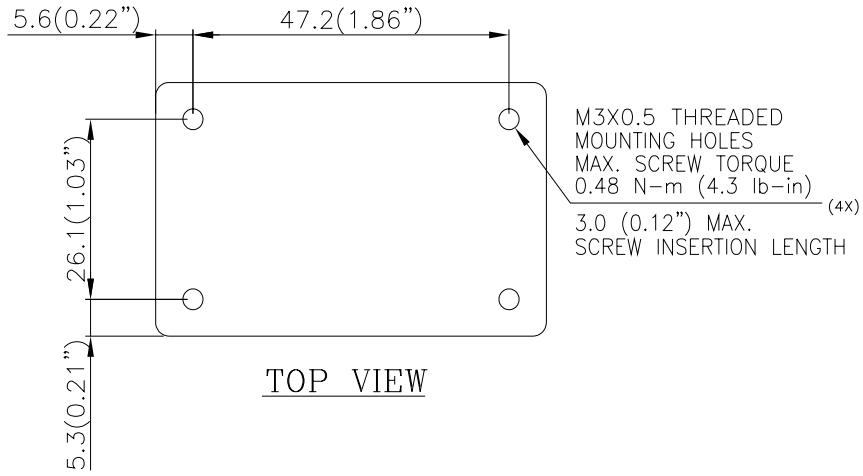

NOTES:
DIMENSIONS ARE IN MILLIMETERS AND (INCHES)
TOLERANCES: X.Xmm±0.5mm(X.XX in.±0.02 in.)
X.XXmm±0.25mm(X.XXX in.±0.010 in.)

PART NUMBERING SYSTEM

Q	48	S	B	9R6	50	N	R	F	A
Type of Product	Input Voltage	Number of Outputs	Product Series	Output Voltage	Output Current	ON/OFF Logic	Pin Length		Option Code
Q- Quarter Brick	48- 48V	S- Single	B- Bus Converter	9R6 - 9.6V	50 - 55A @ 48Vin	N- Negative P- Positive	R- 0.170" N- 0.145" K- 0.110"	F- RoHS 6/6 (Lead Free)	A- 4 output pin, no heat spreader C- 2 output pin, no heat spreader H- 4 output pin, with heat spreader

MODEL LIST

MODEL NAME	INPUT		OUTPUT		Eff. @ 48Vin, 480W Po
Q48SB9R650NRFA	36V~57V	14A	9.6V	55A	96.8%
Q48SB12040NRFA	36V~57V	14A	12V	40A	96.8%

Default remote on/off logic is negative and pin length is 0.170"

Hiccup output OCP and auto-restart OTP are default;

For different remote on/off logic, pin length and output OCP and OTP mode, please refer to part numbering system above or contact your local sales

CONTACT: www.delta.com.tw/dcdc

USA:

Telephone:
East Coast: (888) 335 8201
West Coast: (888) 335 8208
Fax: (978) 656 3964
Email: DCDC@delta-corp.com

Europe:

Telephone: +41 31 998 53 11
Fax: +41 31 998 53 53
Email: DCDC@delta-es.tw

Asia & the rest of world:

Telephone: +886 3 4526107 x6220
Fax: +886 3 4513485
Email: DCDC@delta.com.tw

WARRANTY

Delta offers a two (2) year limited warranty. Complete warranty information is listed on our web site or is available upon request from Delta.

Information furnished by Delta is believed to be accurate and reliable. However, no responsibility is assumed by Delta for its use, nor for any infringements of patents or other rights of third parties, which may result from its use. No license is granted by implication or otherwise under any patent or patent rights of Delta. Delta reserves the right to revise these specifications at any time, without notice.