

PLEASE CHECK WWW.MOLEX.COM FOR LATEST PART INFORMATION

Part Number: [0008650116](#)
Status: **Active**
Overview: [kk](#)
Description: 3.96mm (.156") Pitch KK® Crimp Terminal 2578, 22-26 AWG, Reel, Phosphor Bronze, 0.38µm (15µ") Selective Gold (Au)

Documents:

[Drawing \(PDF\)](#) [RoHS Certificate of Compliance \(PDF\)](#)
[Product Specification PS-08-50 \(PDF\)](#)

General

Product Family Crimp Terminals
 Series [2578](#)
 Crimp Quality Equipment Yes
 Overview [kk](#)
 Product Name KK®

Physical

Gender Female
 Material - Metal Phosphor Bronze
 Material - Plating Mating Gold
 Material - Plating Termination Gold
 Packaging Type Reel
 Plating min: Mating (µin) 15
 Plating min: Mating (µm) 0.375
 Plating min: Termination (µin) 15
 Plating min: Termination (µm) 0.375
 Wire Insulation Diameter 1.65mm (.065") max.
 Wire Size AWG 22, 24, 26
 Wire Size mm² N/A

Material Info

Old Part Number 2578-B-(555)

Reference - Drawing Numbers

Product Specification PS-08-50
 Sales Drawing SD-2578

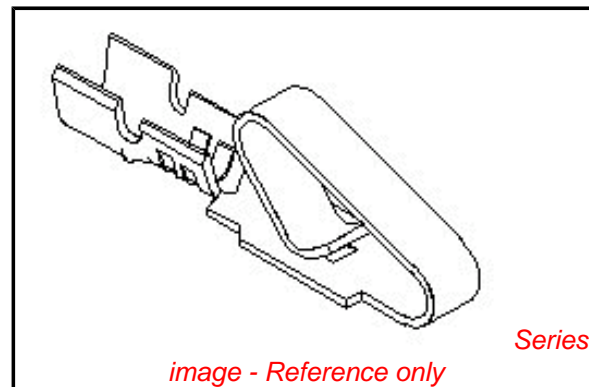

EU RoHS

ELV and RoHS Compliant
REACH SVHC Contains SVHC: No
Halogen-Free Status
Not Reviewed

China RoHS



Need more information on product environmental compliance?

Email productcompliance@molex.com
 For a multiple part number RoHS Certificate of Compliance, [click here](#)

Please visit the [Contact Us](#) section for any non-product compliance questions.

Search Parts in this Series

[2578Series](#)

Use With

[2574](#) , [2139](#) , [41695](#) , [3069](#) , [6422](#) , [5265](#) , [5239](#)

Application Tooling | FAQ

Tooling specifications and manuals are found by selecting the products below. Crimp Height Specifications are then contained in the Application Tooling Specification document.

Global

Description	Product #
HAND CRIMP TOOL	0638117400
Mini-Mac™ Applicator	0638881000
Extraction Tool	0011030016
Terminator Die	0011402097

PLEASE CHECK WWW.MOLEX.COM FOR LATEST PART INFORMATION

- NOTES:
1. CRIMP ACCEPTS 22 TO 26 GA. WIRE WITH (.165)/.065 MAX INSULATION DIA.
 2. DIMENSIONS GIVEN ACROSS CENTERLINES ARE SYMMETRICAL ABOUT THOSE CENTERLINES WITHIN HALF THE TOTAL TOLERANCE.
 3. OPTIONAL DESIGN (.86+.05)/.034+.002
 4. TERMINAL CONFORMS TO PRODUCT SPEC. 08-50.
 5. CAT EAR OPTION TO BE USED WITH 41695 HOUSING ONLY.

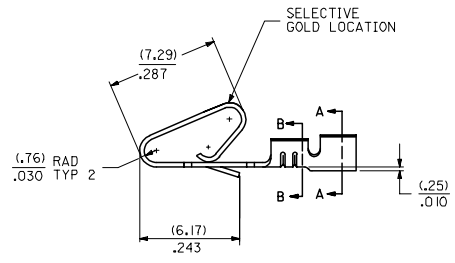
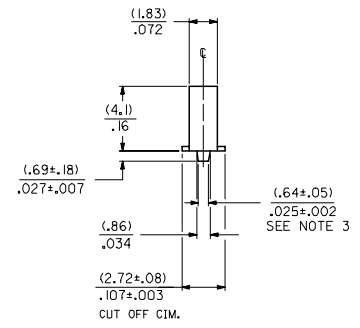
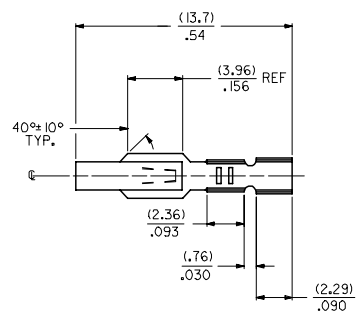
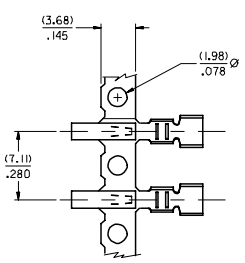
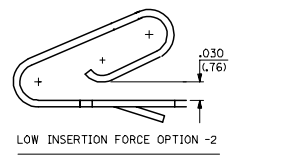
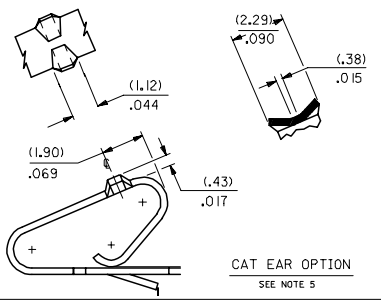

2578 - * - * * *

MATERIAL CODE
 (.28)/.0106 THK
 BLANK=BRASS
 B=PHOS BRONZE

WINDING SPEC.
 A=PER ES-339-A
 BLANK=PER ES-339-B
 L=LOOSE

PLATING CODE
 (PER SDES-88)
 *(P909) OVERALL HOT TIN DIP: 2.54 MICROMETERS MIN
 (550) SELECT GOLD: 0.38 MICROMETERS MIN.
 OVERALL GOLD FLASH: 0.05 MICROMETERS MIN.
 OVERALL NICKEL UNDERPLATE: 0.76 MICROMETERS MIN.
 (555) SELECT GOLD: 0.38 MICROMETERS MIN.
 OVERALL NICKEL UNDERPLATE: 0.76 MICROMETERS MIN.

OPTIONS
 BLANK=AS SHOWN
 1=WITH CAT EARS
 2=LOW INSERTION FORCE

*THE PRIMARY SHIPPING CARTON WILL BE LABELED *COMPLIANT TO ROHS DIRECTIVE 2002/95/EC AND ELV ANNEX II OF DIRECTIVE 2000/53/EC.* CARTONS WITHOUT THIS LABEL MAY CONTAIN PRODUCT WITH TIN-LEAD PLATING.

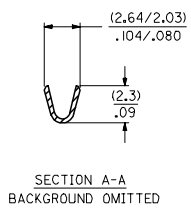
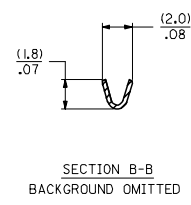

ENTER DESCRIPTION EC NO: UCP2005-0928 DRAWN BY: DRW:ADRIANO CHKD-SAMEC 2004/11/02 APPR:MMAGLIS 2004/11/02 W	QUALITY SYMBOLS ▽=0 ▽=0	GENERAL TOLERANCES (UNLESS SPECIFIED) <table border="1"> <tr> <th></th> <th>mm</th> <th>INCH</th> </tr> <tr> <td>4 PLACES</td> <td>± .15</td> <td>± .005</td> </tr> <tr> <td>3 PLACES</td> <td>± .10</td> <td>± .004</td> </tr> <tr> <td>2 PLACES</td> <td>± 0.25</td> <td>± .010</td> </tr> <tr> <td>1 PLACE</td> <td>± 0.36</td> <td>± .014</td> </tr> <tr> <td colspan="3">ANGULAR ±1/2°</td> </tr> </table>		mm	INCH	4 PLACES	± .15	± .005	3 PLACES	± .10	± .004	2 PLACES	± 0.25	± .010	1 PLACE	± 0.36	± .014	ANGULAR ±1/2°			DIMENSION STYLE IN/MM	SCALE DESIGN UNITS INCH	THIRD ANGLE PROJECTION
		mm	INCH																				
	4 PLACES	± .15	± .005																				
	3 PLACES	± .10	± .004																				
2 PLACES	± 0.25	± .010																					
1 PLACE	± 0.36	± .014																					
ANGULAR ±1/2°																							
DRAFT WHERE APPLICABLE MUST REMAIN WITHIN DIMENSIONS	SEE CHART SIZE D	MATERIAL NO. DOCUMENT NO. SD-2578	TITLE CRIMP TERMINAL (.396)/.156 CENTERS 22 TO 26 GA WIRE MOLEX INCORPORATED	SHEET NO. 1 OF 2																			
THIS DRAWING CONTAINS INFORMATION THAT IS PROPRIETARY TO MOLEX INCORPORATED AND SHOULD NOT BE USED WITHOUT WRITTEN PERMISSION																							

2578-(***)*		2578-B-(***)*		2578-B-2-(***)*							
PART NO.	ENG. NO.	PART NO.	ENG. NO.	PART NO.	ENG. NO.	PART NO.	ENG. NO.	PART NO.	ENG. NO.	PART NO.	ENG. NO.
08-50-0107	2578-(P909)	08-56-0121	2578-B-(501)		2578-B-2(P909)						
08-50-0108	2578-(P909)L	08-56-0122	2578-B-(501)L		2578-B-2(P909)L						
08-50-0111	2578-(109)	08-50-0133 *	2578-B-(P909)		2578-B-2(555)						
08-50-0112	2578-(109)L	08-50-0134 *	2578-B-(P909)L		2578-B-2(555)L						
08-56-0107	2578-(550)	08-65-0116 *	2578-B-(555)		2578-B-2(550)						
08-56-0108	2578-(550)L	08-65-0117 *	2578-B-(555)L		2578-B-2(550)L						
08-55-0105	2578-(555)	08-65-0108	2578-B-(591)								
08-56-0106	2578-(555)L	08-65-0107	2578-B-(591)L								
08-59-0101	2578-(122)	08-60-0003	2578-B-(122)								
	2578-(122)L	08-60-0004	2578-B-(122)L								
1 08-56-0162	2578-(505)	08-65-0110	2578-B-(558)								
1 08-56-0163	2578-(505)L	08-65-0111	2578-B-(558)L								
08-50-0504	2578-(128)	08-58-0125 *	2578-B-(550)								
	2578-(128)L	08-58-0126 *	2578-B-(550)L								
08-56-0161	2578-(503)										
	2578-(503)L										
1 08-50-0061	2578-(224)										
1 08-50-0062	2578-(224)L										
1 08-50-0065	2578-(P224)										
1 08-50-0066	2578-(P224)L										
08-55-0137	2578-(558)A										
	2578-(558)L										
08-50-0018	2578-(102)										
08-50-0019	2578-(102)L										
08-55-0121	2578-(561)										
08-55-0132	2578-(561)L										
08-55-0123	2578-(558)										
	2578-(558)L										
08-65-0109	2578-(555)A										
08-52-0116	2578-(P909)										
08-52-0117	2578-(P9109)L										

CHANGE TO ME10 EC NO: UCP2005-0928 DRW:ADRIANO 2004/11/16 CHK:CSAMEC 2004/11/02 APPR: MARGULLIS 2004/11/02 W	QUALITY SYMBOLS ▽=0 ▽=0	GENERAL TOLERANCES (UNLESS SPECIFIED) <table border="1"> <tr> <th></th> <th>mm</th> <th>INCH</th> </tr> <tr> <td>4 PLACES</td> <td>± .005</td> <td>± .0005</td> </tr> <tr> <td>3 PLACES</td> <td>± .005</td> <td>± .0005</td> </tr> <tr> <td>2 PLACES</td> <td>± .005</td> <td>± .0005</td> </tr> <tr> <td>1 PLACE</td> <td>± .005</td> <td>± .0005</td> </tr> </table>		mm	INCH	4 PLACES	± .005	± .0005	3 PLACES	± .005	± .0005	2 PLACES	± .005	± .0005	1 PLACE	± .005	± .0005	DIMENSION STYLE IN/MM	SCALE INCH	DESIGN UNITS INCH	THIRD ANGLE PROJECTION
		mm	INCH																		
	4 PLACES	± .005	± .0005																		
	3 PLACES	± .005	± .0005																		
2 PLACES	± .005	± .0005																			
1 PLACE	± .005	± .0005																			
DRAWN BY PEREZ/AR	DATE 01/29/87	CHECKED BY PATEL	DATE 01/29/87	APPROVED BY LENZ	DATE 01/29/87	MATERIAL NO. DOCUMENT NO. SD-2578															
DRAFT WHERE APPLICABLE MUST REMAIN WITHIN DIMENSIONS						SIZE D	THIS DRAWING CONTAINS INFORMATION THAT IS PROPRIETARY TO MOLEX INCORPORATED AND SHOULD NOT BE USED WITHOUT WRITTEN PERMISSION														
CRIMP TERMINAL (3,96)/.156 CENTERS 22 TO 26 GA WIRE						MOLEX INCORPORATED	SHEET NO. 2														