

## Silicon NPN Power Transistors

2SD1088

## DESCRIPTION

- With TO-220 package
- High DC current gain
- DARLINGTON

## APPLICATIONS

- For switching igniter applications

## PINNING

PIN	DESCRIPTION
1	Base
2	Collector;connected to mounting base
3	Emitter

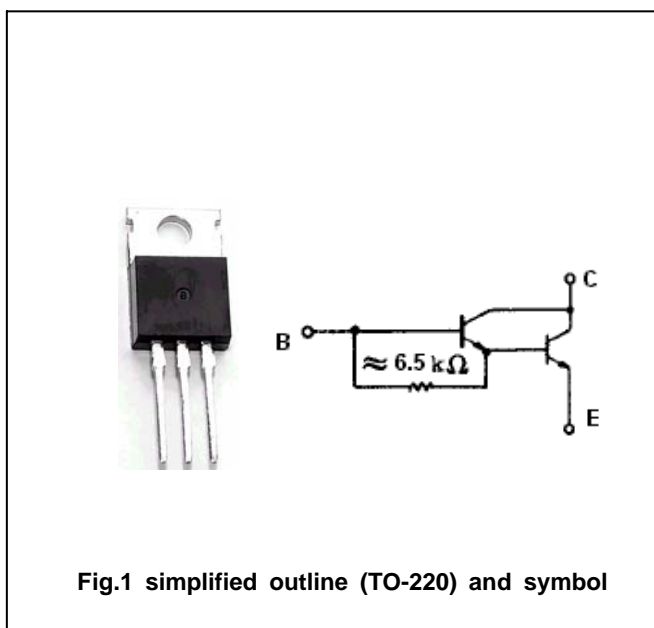

## Absolute maximum ratings (Ta=25°C)

SYMBOL	PARAMETER	CONDITIONS	VALUE	UNIT
V <sub>CBO</sub>	Collector-base voltage	Open emitter	300	V
V <sub>CEO</sub>	Collector-emitter voltage	Open base	250	V
V <sub>EBO</sub>	Emitter-base voltage	Open collector	5	V
I <sub>C</sub>	Collector current-continuous		6	A
I <sub>CM</sub>	Collector current-peak		10	A
I <sub>B</sub>	Base current		1	A
P <sub>D</sub>	Total power dissipation	T <sub>C</sub> =25°C	30	W
T <sub>j</sub>	Junction temperature		150	°C
T <sub>stg</sub>	Storage temperature		-55~150	°C

## Silicon NPN Power Transistors

## 2SD1088

## CHARACTERISTICS

T<sub>j</sub>=25°C unless otherwise specified

SYMBOL	PARAMETER	CONDITIONS	MIN	TYP.	MAX	UNIT
V <sub>CEO(SUS)</sub>	Collector-emitter sustaining voltage	I <sub>C</sub> =0.5A ; L=40mH	250			V
V <sub>CEsat</sub>	Collector-emitter saturation voltage	I <sub>C</sub> =4A ; I <sub>B</sub> =0.04A			2.0	V
V <sub>BEsat</sub>	Base-emitter saturation voltage	I <sub>C</sub> =4A ; I <sub>B</sub> =0.04A			2.5	V
I <sub>CBO</sub>	Collector cut-off current	V <sub>CB</sub> =300V ; I <sub>E</sub> =0			0.5	mA
I <sub>EBO</sub>	Emitter cut-off current	V <sub>EB</sub> =5V ; I <sub>C</sub> =0			0.5	mA
h <sub>FE-1</sub>	DC current gain	I <sub>C</sub> =2A ; V <sub>CE</sub> =2V	2000			
h <sub>FE-2</sub>	DC current gain	I <sub>C</sub> =4A ; V <sub>CE</sub> =2V	200			
C <sub>OB</sub>	Collector output capacitance	f=1MHz ; V <sub>CB</sub> =50V		35		pF

Silicon NPN Power Transistors

2SD1088

PACKAGE OUTLINE

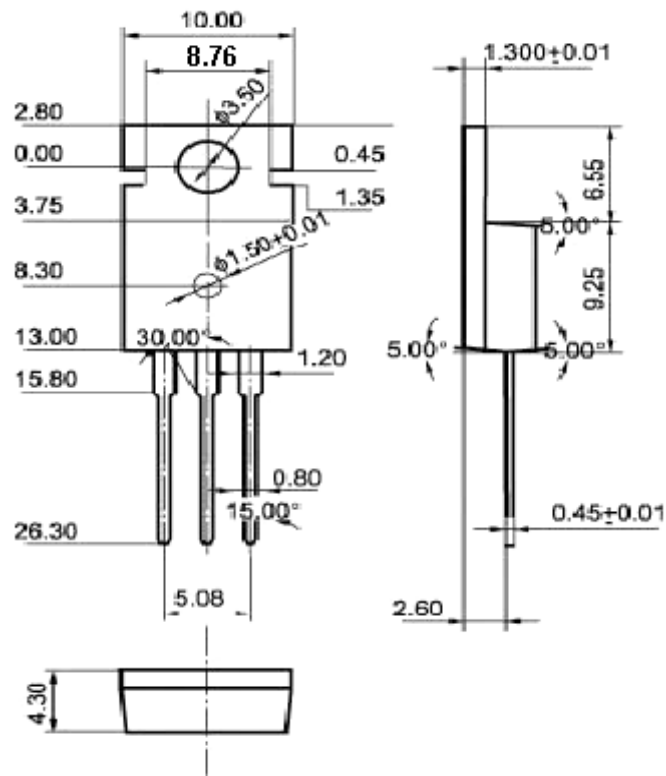

Fig.2 Outline dimensions (unindicated tolerance:  $\pm 0.10$  mm)

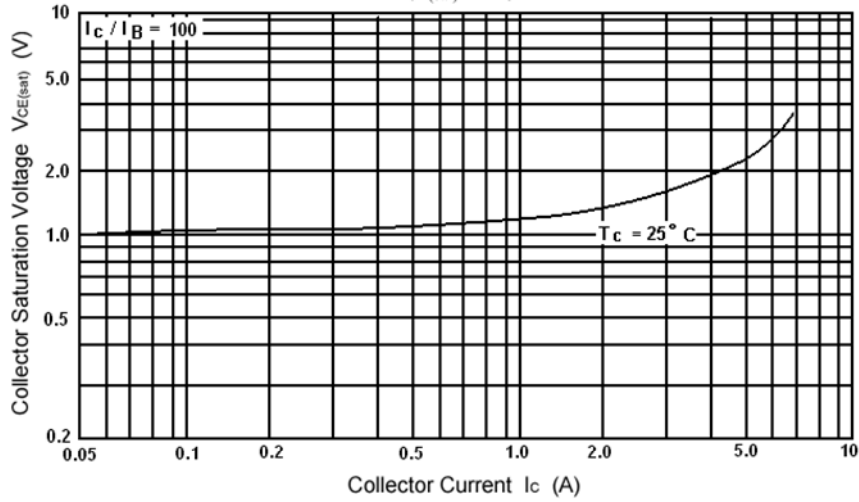

Fig.3 Collector-Emitter Saturation Voltage

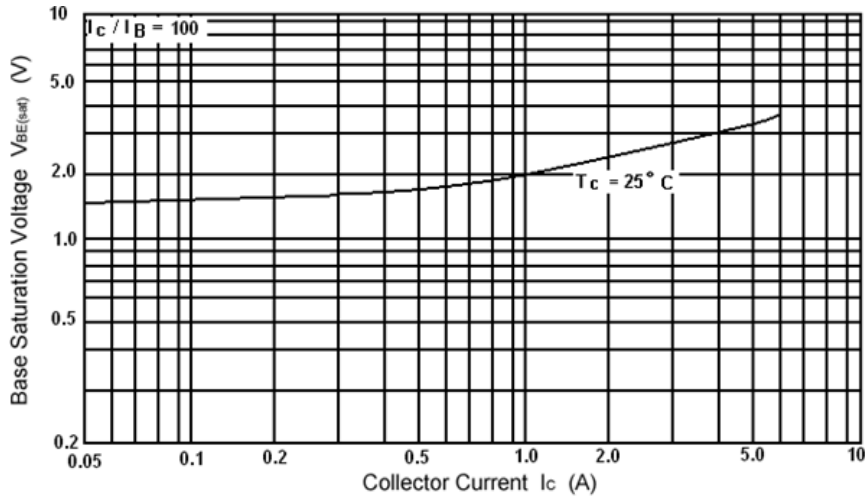

Fig.4 Base-Emitter Saturation Voltage

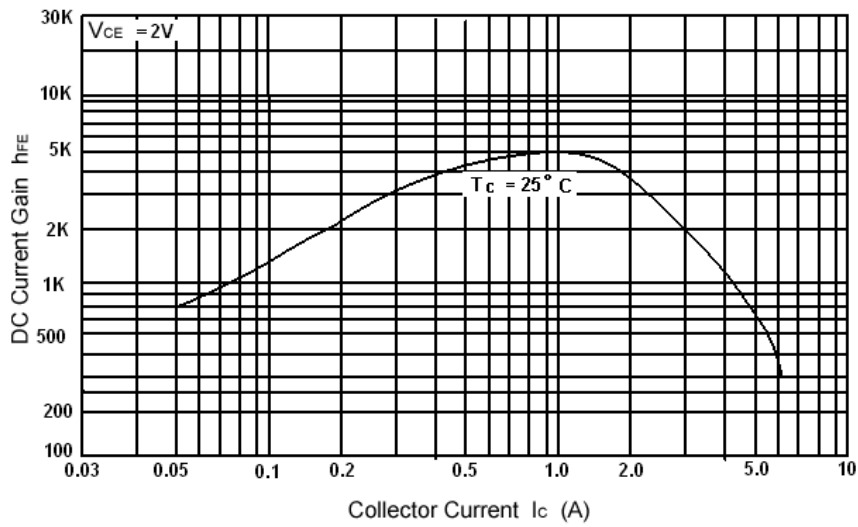

Fig.5 DC current Gain

Silicon NPN Power Transistors

2SD1088

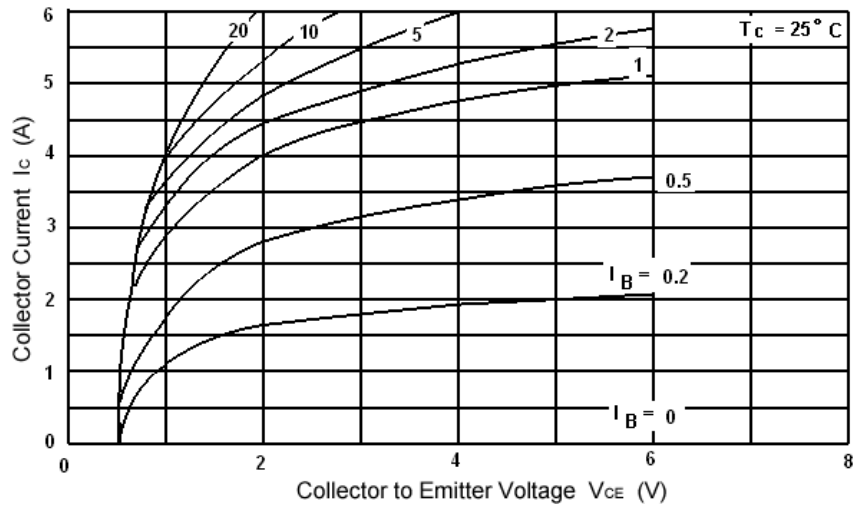

Fig.6 Static Characteristic

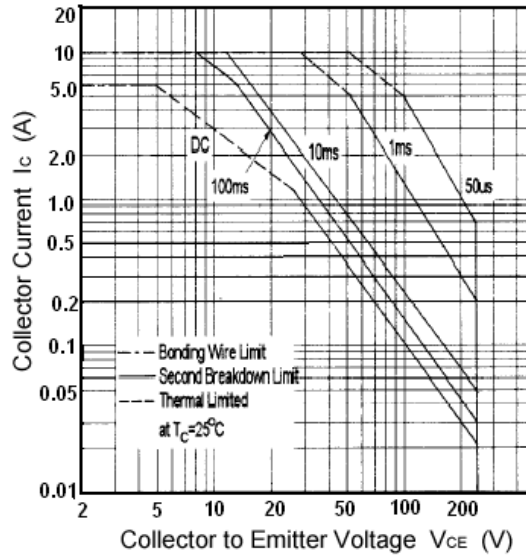

Fig.7 Safe Operating Area