

Metal Switch Medium Stroke, Switching Voltage up to 250 VAC



See below:

Approvals and Compliances

Description

- Momentary action switch available in version: Standard (ST), with Lettering (LE) and with Ring Illumination (RI) Assembly method: clip micro-switch into the saddle, secure switch using mounting nut
- Equipped with flat-pin plugs to permit fast connection

Unique Selling Proposition

- Attractive tactile feedback
- High quality materials
- Long life span
- Homogeneous illumination

Characteristics

- Housing and actuator material: high-quality stainless steel
- Variety of design options regarding size, colour, illumination, connection or lettering
- Switching voltage from 30 VDC to 250 VAC, switching current from 0.1 A to 10 A
- IP-Protection: IP 67 from front side to contact area, Micro-Switch is available in versions IP 40 or IP 67
- for use in harsh environments (see technical data)

References

- Alternative: double-pole switch: [MSM DP 22](#); [MSM DP 30](#)
- Alternative: switch with latching function: [MSM LA CS 19](#); [MSM LA CS 22](#); [MSM LA 19](#); [MSM LA 22](#)
- Alternative: switch with backlighted illumination: [MSM CS 16](#); [MSM CS 19](#); [MSM CS 22](#)
- Alternative: Other diameter [MSM 19](#); [MSM 22](#); [MSM 30](#)

Weblinks

[html-datasheet](#), [General Product Information](#), [CAD-Drawings](#), [Product News](#), [Detailed request for product](#)

Technical Data**Electrical Data**

Switching Function	N.O., N.C., N.O./N.C.
Number of Poles	1-pole
Supply Voltage	24 VDC Ring Illumination
Impulse Withstand Voltage (ESD)	4 kV MSM ST / MSM LE
	2 kV MSM RI

Micro Switch 5 A / 125 VAC or 3 A / 250 VAC, IP40

Contact Material	Ag
Switching Voltage	max. 125 / 250 VAC
Switching Current	max. 5 / 3 A
Rated Switching Capacity	750 W
Lifetime	0.2 million actuations at Rated Switching Capacity
Contact Resistance	< 30 mΩ
Insulation Resistance	> 100 MΩ
Duration of Bounce	< 5 ms

Micro Switch 0,1 A / 30 VDC, IP40

Contact Material	Au
Switching Voltage	max. 30 VDC
Switching Current	max. 0.1 A
Rated Switching Capacity	3 W
Lifetime	0.2 million actuations at Rated Switching Capacity
Contact Resistance	< 50 mΩ
Insulation Resistance	> 100 MΩ
Duration of Bounce	< 5 ms

Micro Switch for Electrical Rating 10 A / 250 VAC (Protection Class IP40)

Contact Material	Ag
Switching Voltage	max. 250 VAC
Switching Current	max. 10 A
Rated Switching Capacity	2500 W
Lifetime	0.05 million actuations at Rated Switching Capacity
Contact Resistance	< 30 mΩ
Insulation Resistance	> 100 MΩ
Duration of Bounce	< 5 ms

Micro Switch 6 A / 250 VAC, IP67

Switching Voltage	max. 250 VAC
Switching Current	max. 5
Rated Switching Capacity	1250 W
Lifetime	0.05 million actuations at Rated Switching Capacity

Micro Switch 0,1 A / 250 VAC, IP67 - on request

Switching Voltage	max. 250 VAC
Switching Current	max. 0.1
Rated Switching Capacity	25 W
Lifetime	0.05 million actuations at Rated Switching Capacity

Micro Switch 10 A / 250 VAC, IP67 - on request

Switching Voltage	max. 250 VAC
Switching Current	max. 10 A
Rated Switching Capacity	2500 W
Lifetime	0.01 million actuations at Rated Switching Capacity

Mechanical Data

Actuating Force	4.5 N
Actuating Travel	1.0 mm
Lifetime	1.5 million actuations
Shock Protection	IK 07 for ring illuminated variants, IK 10 for non-illuminated variants
Tightening Torque Plastic Nut	max. 2 Nm
Tightening Torque Stainless Steel Nut	max. 10 Nm

Climatical Data

Operating Temperature	-25 to +85 °C
Storage Temperature	-25 to +85 °C
Protection Class	IP 67
Switching Unit	IP 40
	IP 67 optional
Salt Spray Test (acc. to DIN 50021-SS)	24 h / 48 h / 96 h Residence Time

Material

Housings	Stainless Steel
Actuator	Stainless Steel
Light Conductor (Point Illumination)	PC
Illuminated Ring (Ring Illumination)	PMMA
Seal Ring	NBR70
Switcher Collet	PA

Approvals and Compliances

Detailed information on product approvals, code requirements, usage instructions and detailed test conditions can be looked up in [Details about Approvals](#)

Approvals

Approval Reference Type: MSM 16

Approval Logo	Certification Body	Description
VDE		Low Voltage Directive 2014/35/EU compliant following certificate numbers apply to micro switch
VDE		VDE / ENEC Certificate Number (Omron): 40008425, 129246, 125256
UL	UL	UL / CSA File Number (Omron): E41515
VDE		VDE / ENEC Certificate Number (Marquardt): 097550
UL	UL	UL / CSA File Number (Marquardt): E41791
KEMA EUR	KEMA	KEMA / ENEC File Number (Cherry): 2089323.01
UL	UL	UL / CSA File Number (Cherry): E23301
CQC	CQC	CQC File Number (Marquardt): CQC13005090991

Product standards

Product standards that are referenced

Organization	Design	Standard	Description
DIN	Designed according to	DIN EN 61058-1	Switches for appliances. Part 1. General requirements
UL	Designed according to	UL 1054	UL standard for safety special-use switches

Application standards

Application standards where the product can be used

Organization	Design	Standard	Description
IEC	Designed for applications acc.	IEC/UL 60950	IEC 60950-1 includes the basic requirements for the safety of information technology equipment.

Compliances

The product complies with following Guide Lines

Identification	Details	Initiator	Description
RoHS COMPLIANT	RoHS	SCHURTER AG	EU Directive RoHS 2011/65/EU
REACH	REACH	SCHURTER AG	On 1 June 2007, Regulation (EC) No 1907/2006 on the Registration, Evaluation, Authorization and Restriction of Chemicals 1 (abbreviated as "REACH") entered into force.

Dimension [mm]

MSM 16 ST

MSM 16 LE

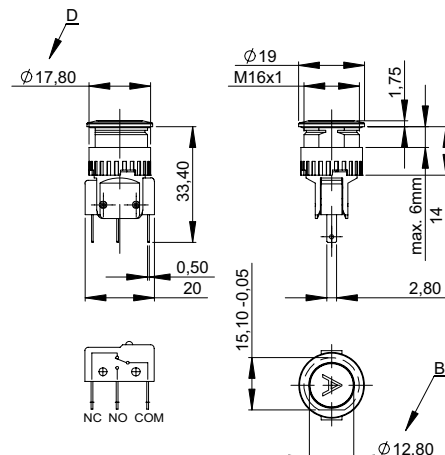
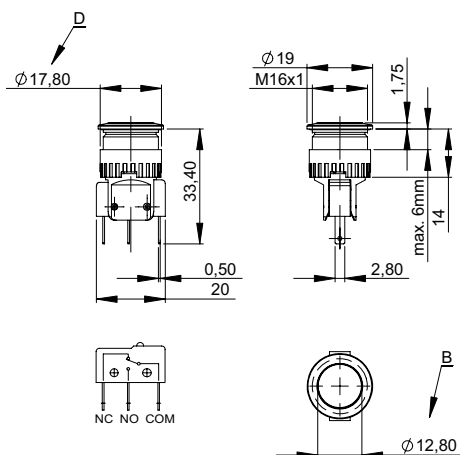

MSM RI

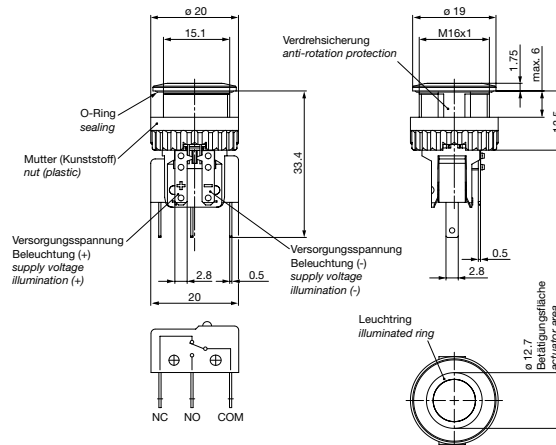

Legend

- A = Illumination Area
- B = Actuating Area
- C = Width Across Flats
- D = Nut

Tolerance Range

Actuator Tolerance Range

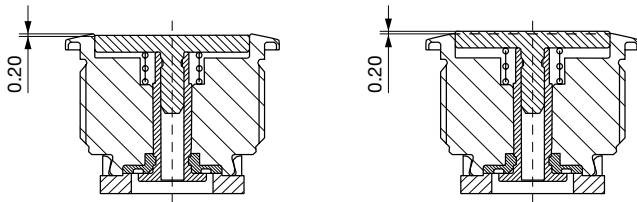

The mounting tolerance range of the actuator varies from 0.2 mm projection length and 0.2 mm short length to the housing edge. The slanting position of the actuator can range within this tolerance.

Dimension

MSM 16 ST

MSM 16 LE, RI

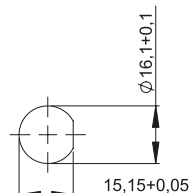
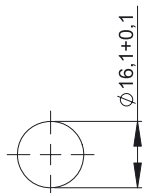

Drilling diagram

Assembly Instructions

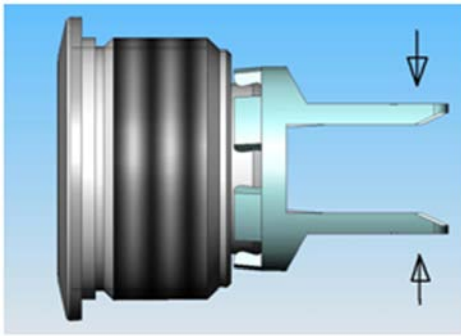

During assembly, the protruding bars of the holder should not be pressed together.

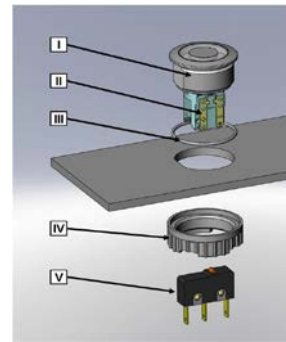

- I Housing
- II Flat Pin Terminal (Illumination)
- III Gasket
- IV Nut (Nut type see Dimensions)
- V Module Switching Contact

Installation Instruction:

- 1.) Place the gasket accurately on the actuator housing. Then mount the actuator housing assembly into the panel.
- 2.) Tighten the screw nut according to the torque instructions.
- 3.) Clasp the module switching contact into the micro switch holder of the actuator housing.

Installation information:

- 1.) The power supply and the configuration of the flat pin terminals have to be installed correctly for the illumination and micro switch function.
- 2.) Insulate the terminals as required. Fully insulated plug-in sleeves are recommended.
- 3.) Installation instructions according to VDE-standard DIN VDE 0100-100 or alternatively IEC 60354 standard.

Diagrams

MSM ST / MSM LE

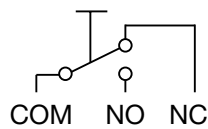

MSM RI

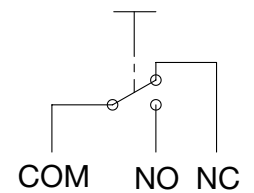
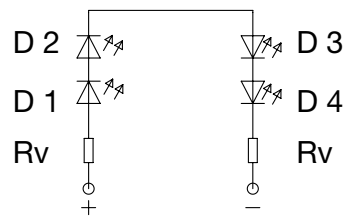

Lettering





The last three digits in the order number define the lettering:

000	No Lettering
001-074	Standard Lettering
101-	Customized Lettering

Lettering Colour of Laser Lettering

Material	Lettering Colour
Stainless Steel	black Filled letters

Order Index Lettering

Laser Marking			
001 = A	021 = U	041 = ÷	061 = EIN
002 = B	022 = V	042 = *	062 = AUS
003 = C	023 = W	043 = =	063 = AUF
004 = D	024 = X	044 = #	064 = AB
005 = E	025 = Y	045 = ↔	065 = ON
006 = F	026 = Z	046 = †	066 = OFF
007 = G	027 = 0	047 = →	067 = UP
008 = H	028 = 1	048 = ←	068 = DOWN
009 = I	029 = 2	049 = ↓	069 = HIGH
010 = J	030 = 3	050 = ↑	070 = LOW
011 = K	031 = 4	051 = %	071 = ON/OFF
012 = L	032 = 5	052 = √	072 = START
013 = M	033 = 6	053 = CTRL	073 = RESET
014 = N	034 = 7	054 = RETURN	074 = 
015 = O	035 = 8	055 = SHIFT	075 = 
016 = P	036 = 9	056 = LOCK	076 = 
017 = Q	037 = +	057 = STOP	077 = 
018 = R	038 = -	058 = ENTER	
019 = S	039 = .	059 = BACK	
020 = T	040 = x	060 = LINE	

All Variants

IP Switching Unit	Switching Current [A]	Switching Voltage [VAC/VDC]	Illumination, LED	Housing Material, Torsion Protection	Actuator Material, Torsion Protection	Config. Code	Order Number
IP 40	100 mA	30 VDC	non-illuminated	Stainless Steel ,no	Stainless Steel ,no	MSM 16 ST	1241.6611.1110000
IP 40	5 / 3 A	125 / 250 VAC	non-illuminated	Stainless Steel ,no	Stainless Steel ,no	MSM 16 ST	1241.6611.1120000
IP 40	10 A	250 VAC	non-illuminated	Stainless Steel ,no	Stainless Steel ,no	MSM 16 ST	1241.6611.1130000
IP 40	100 mA	30 VDC	non-illuminated	Stainless Steel ,yes	Stainless Steel ,yes	MSM 16 LE	1241.6612.1110074
IP 40	5 / 3 A	125 / 250 VAC	non-illuminated	Stainless Steel ,yes	Stainless Steel ,yes	MSM 16 LE	1241.6612.1120000
IP 40	100 mA	30 VDC	Ring Illumination, red, 24 VDC	Stainless Steel ,yes	Stainless Steel ,yes	MSM 16 RI red	3-102-618
IP 40	10 A	250 VAC	Ring Illumination, red, 24 VDC	Stainless Steel ,yes	Stainless Steel ,yes	MSM 16 RI red	3-102-620
IP 40	100 mA	30 VDC	Ring Illumination, green, 24 VDC	Stainless Steel ,yes	Stainless Steel ,yes	MSM 16 RI green	3-102-621
IP 40	10 A	250 VAC	Ring Illumination, green, 24 VDC	Stainless Steel ,yes	Stainless Steel ,yes	MSM 16 RI green	3-102-623
IP 40	100 mA	30 VDC	Ring Illumination, blue, 24 VDC	Stainless Steel ,yes	Stainless Steel ,yes	MSM 16 RI blue	3-102-624
IP 40	10 A	250 VAC	Ring Illumination, blue, 24 VDC	Stainless Steel ,yes	Stainless Steel ,yes	MSM 16 RI blue	3-102-626
IP 40	100 mA	30 VDC	Ring Illumination, yellow, 24 VDC	Stainless Steel ,yes	Stainless Steel ,yes	MSM 16 RI yellow	3-102-627
IP 40	10 A	250 VAC	Ring Illumination, yellow, 24 VDC	Stainless Steel ,yes	Stainless Steel ,yes	MSM 16 RI yellow	3-102-629
IP 40	100 mA	30 VDC	Ring Illumination, white, 24 VDC	Stainless Steel ,yes	Stainless Steel ,yes	MSM 16 RI white	3-102-630
IP 40	10 A	250 VAC	Ring Illumination, white, 24 VDC	Stainless Steel ,yes	Stainless Steel ,yes	MSM 16 RI white	3-102-632

Legend:

Type:

MSMST = Standard: not lettered

LE = Lettering: lettered

RI = Ring Illumination

IP-Protection: IP 67 from front side to contact area, Micro-Switch is available in versions IP 40 or IP 67, see Technical Data Micro-Switch

Variants with 6 A micro switch have IP67

The MOQ for standard laser lettering on standard variants is 10 pieces.

Customer-specific versions available on request.

Special materials for use in salt and chlorinated environment on request.

The nut with gasket and micro switch are enclosed in the box.

 Most Popular.

IP Switching Unit	Switching Current	Switching Voltage	Illumination, LED	Housing Material, Torsion Protection	Actuator Material, Torsion Protection	Config. Code	Order Number
	[A]	[VAC/ VDC]					

Availability for all products can be searched real-time: <https://www.schurter.com/en/Stock-Check/Stock-Check-SCHURTER>

Packaging unit 10 in box with insert or packed in air cushion bags



- Actuating elements in ESD safe packaging
- Screw nuts and sealing rings in a bag (enclosed in the box)
- Micro switches in a bag (enclosed in the box)

Accessories

Description



Installation Wrench MSM 16
 Installation Wrench



Power Supply
 Power Supply IP42 for LED- and Illumination applications indoor 90~264 VAC => 24 VDC 0.34 A 8 W