

UCM Chip Type, Low Impedance

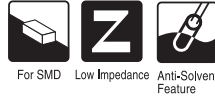

- Chip type, low impedance temperature range up to +105°C.
- Applicable to automatic mounting machine fed with carrier tape.
- Compliant to the RoHS directive (2011/65/EU).

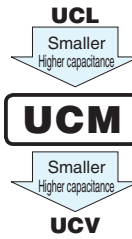

Specifications

Item	Performance Characteristics								
Category Temperature Range	-55 to +105°C								
Rated Voltage Range	6.3 to 50V								
Rated Capacitance Range	10 to 2200μF								
Capacitance Tolerance	±20% at 120Hz, 20°C								
Leakage Current	After 2 minutes' application of rated voltage, leakage current is not more than 0.01 CV								
Tangent of loss angle (tan δ)	Rated voltage (V)	6.3	10	16	25	35	50	Measurement frequency : 120Hz at 20°C	
	tan δ (MAX.)	0.26	0.19	0.16	0.14	0.12	0.10		
Stability at Low Temperature	Rated voltage (V)		6.3	10	16	25	35	50	Measurement frequency : 120Hz
	Impedance ratio ZT / Z20 (MAX.)	Z-25°C / Z+20°C	2	2	2	2	2	2	
		Z-40°C / Z+20°C	3	3	3	3	3	3	
		Z-55°C / Z+20°C	4	4	4	3	3	3	
Endurance	The specifications listed at right shall be met when the capacitors are restored to 20°C after the rated voltage is applied for 2000 hours at 105°C.							Capacitance change	Within ±30% of the initial capacitance value
								tan δ	200% or less than the initial specified value
								Leakage current	Less than or equal to the initial specified value
Shelf Life	After storing the capacitors under no load at 105°C for 1000 hours and then performing voltage treatment based on JIS C 5101-4 clause 4.1 at 20°C, they shall meet the specified values for the endurance characteristics listed above.								
Resistance to soldering heat	The capacitors are kept on a hot plate for 30 seconds, which is maintained at 250°C. The capacitors shall meet the characteristic requirements listed at right when they are removed from the plate and restored to 20°C.							Capacitance change	Within ±10% of the initial capacitance value
								tan δ	Less than or equal to the initial specified value
								Leakage current	Less than or equal to the initial specified value
Marking	Black print on the case top.								

Chip Type

(φ4 to φ6.3)

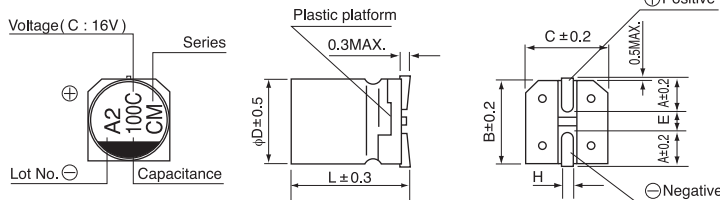

(φ8 × 10L, φ10)

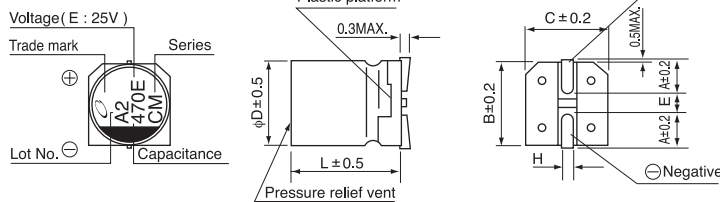

Type numbering system (Example : 16V 100μF)

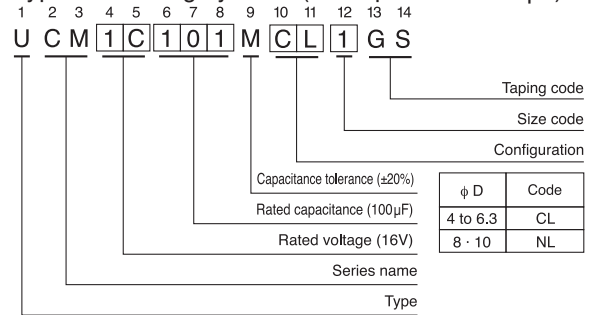

	(mm)					
φD×L	4×5.8	5×5.8	6.3×5.8	6.3×7.7	8×10	10×10
A	1.8	2.1	2.4	2.4	2.9	3.2
B	4.3	5.3	6.6	6.6	8.3	10.3
C	4.3	5.3	6.6	6.6	8.3	10.3
E	1.0	1.3	2.2	2.2	3.1	4.5
L	5.8	5.8	5.8	7.7	10	10
H	0.5 to 0.8	0.5 to 0.8	0.5 to 0.8	0.5 to 0.8	0.8 to 1.1	0.8 to 1.1

Voltage

V	6.3	10	16	25	35	50
Code	j	A	C	E	V	H

● Dimension table in next page.

UCM

■ Dimensions

Cap. (μ F)	V Code	6.3			10			16			25			35			50		
		0J			1A			1C			1E			1V			1H		
10	100																● 4 × 5.8	2.30	85
																	5 × 5.8	0.88	165
22	220									4 × 5.8	1.00	160	4 × 5.8	1.00	160	5 × 5.8	0.88	165	
33	330									4 × 5.8	1.00	160	5 × 5.8	0.36	240				
47	470							4 × 5.8	1.00	160	5 × 5.8	0.36	240	5 × 5.8	0.36	240	6.3 × 5.8	0.68	195
68	680				4 × 5.8	1.00	160	5 × 5.8	0.36	240	5 × 5.8	0.36	240	6.3 × 5.8	0.26	300			
100	101	4 × 5.8	1.00	160				5 × 5.8	0.36	240	6.3 × 5.8	0.26	300	6.3 × 5.8	0.26	300	6.3 × 7.7	0.34	350
150	151				5 × 5.8	0.36	240	6.3 × 5.8	0.26	300	6.3 × 7.7	0.16	600	6.3 × 7.7	0.16	600			
220	221	5 × 5.8	0.36	240	6.3 × 5.8	0.26	300	6.3 × 5.8	0.26	300	6.3 × 7.7	0.16	600				8 × 10	0.18	670
330	331	6.3 × 5.8	0.26	300	6.3 × 7.7	0.16	600	6.3 × 7.7	0.16	600							8 × 10	0.08	850
470	471	6.3 × 7.7	0.16	600	6.3 × 7.7	0.16	600				8 × 10	0.08	850						
560	561													10 × 10	0.06	1190			
680	681	6.3 × 7.7	0.16	600				8 × 10	0.08	850									
820	821										10 × 10	0.06	1190						
1000	102				8 × 10	0.08	850	10 × 10	0.06	1190									
1500	152	8 × 10	0.08	850	10 × 10	0.06	1190												
2200	222	10 × 10	0.06	1190													Case size ϕ D × L (mm)	Impedance	Rated ripple

MAX. Impedance (Ω) at 20°C 100kHz, Rated ripple current(mArms) at 105°C 100kHz
 ● In this case, [6] will be put at 12th digit of type numbering system.

● Frequency coefficient of rated ripple current

Frequency	50 Hz	120 Hz	300 Hz	1 kHz	10 kHz or more
Coefficient	0.35	0.50	0.64	0.83	1.00

- Taping specifications are given in page 23.
- Recommended land size, soldering by reflow are given in page 18, 19.
- Please refer to page 3 for the minimum order quantity.