

REVISIONS

P	LTR	DESCRIPTION	DATE	DWN	APVD
1		INITIAL ISSUE	28AUG2020	SM	MZ
2		INFORMATION ADDED TO SHEET 2	01OCT2020	SM	MZ
3		DRAFTING UPDATE	29OCT2020	SM	MZ
A		PRODUCT UNDER TESTING	24NOV2020	SM	MZ

NOTES:

1 CONTACTS SUPPLIED SEPARATELY ON REELS, MUST PURCHASED ACCORDING TO WIRE SIZES. BELOW ARE THE CONTACT PART NUMBERS:

CONTACT P/N	WIRE SIZE
2359527-1	1.5mm ² TO 2.5mm ² 16AWG TO 14AWG
2359527-2	4.0mm ² 12AWG

- MATERIALS:
PLASTICS: PBT+PC ALLOY, UL-V0, UV-F1
CONTACTS: COPPER ALLOY, TIN PLATED
SCREWS : STAINLESS STEEL
- OPERATING RATINGS :
VOLTAGE (max): 600Vac Max
CURRENT (max): 25A ON 4.0mm² & 20A ON 12AWG
TEMPERATURE : -40°C TO 85°C
IP RATING : IP67 & IP68
- FOR ASSEMBLY INSTRUCTIONS, REFER APPLICATION SPECIFICATION 114-133123
- PACKAGING: MOQ 200 pcs IN PE BAG

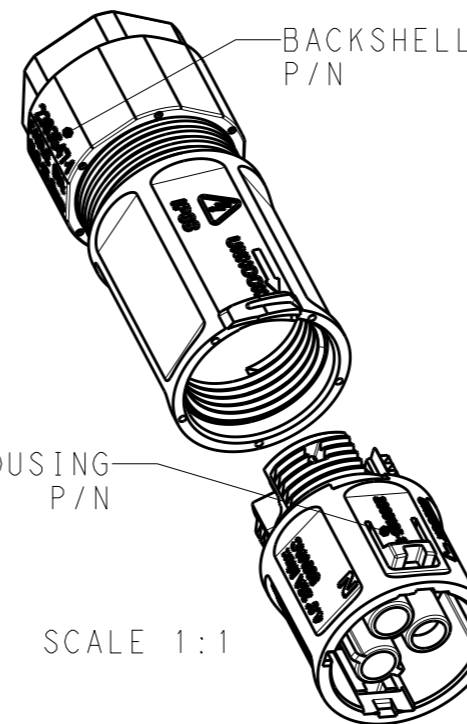
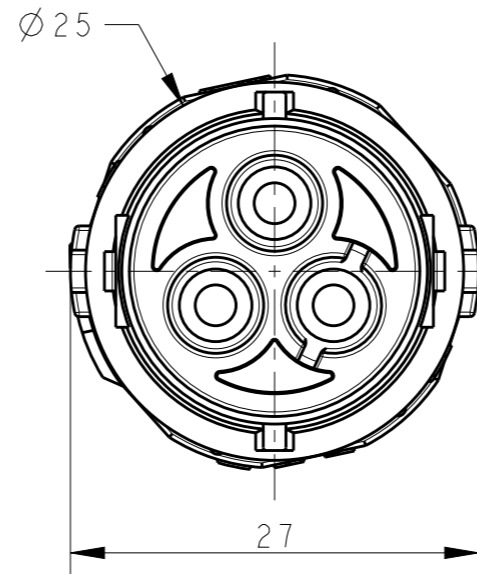
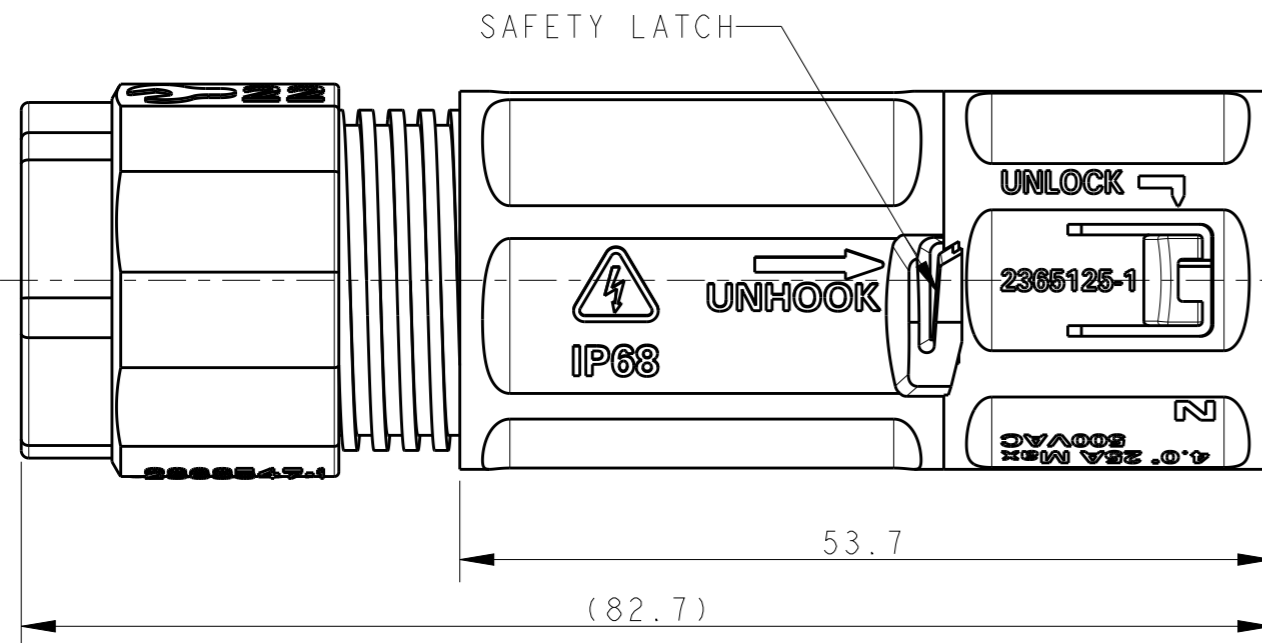

PRODUCT UNDER TESTING
CONTACT PRODUCT ENGINEERING BEFORE USING THIS PRINT

POLARIZING KEY A
2379239-1
1-2379239-1

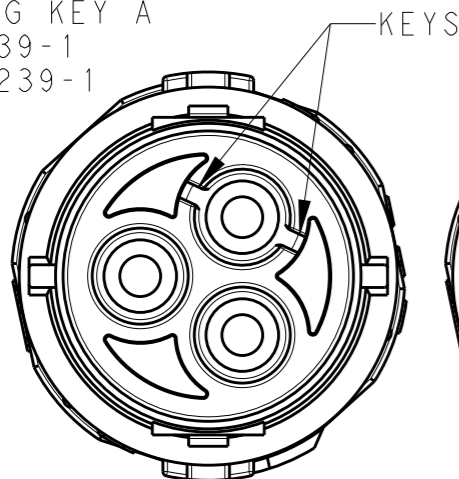

POLARIZING KEY B
2379239-2
1-2379239-2

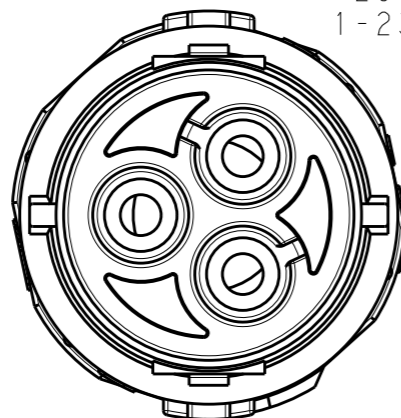

BACKSHELL FOR
2379239-1
2379239-2

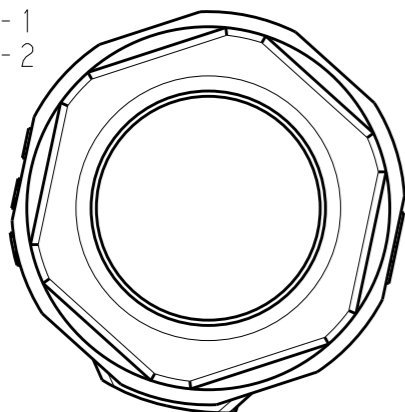

BACKSHELL FOR
1-2379239-1
1-2379239-2

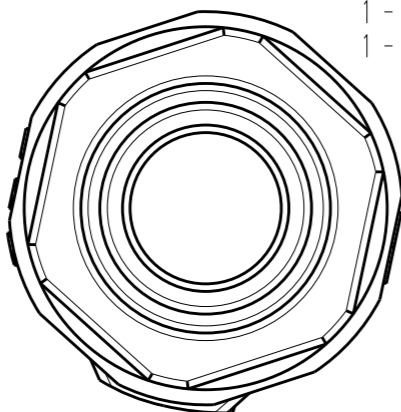

BACKSHELL P/N	HOUSING ASSY P/N	POLARIZING KEY	CABLE RANGE	DESCRIPTION	PART NUMBER
2363547-2	2365125-2	KEY B	Ø7 - Ø10	IN-LINE SOCKET CONNECTOR	1-2379239-2
	2365125-1	KEY A			1-2379239-1
2363547-1	2365125-2	KEY B	Ø10.5 - Ø15	IN-LINE SOCKET CONNECTOR	2379239-2
	2365125-1	KEY A			2379239-1

THIS DRAWING IS A CONTROLLED DOCUMENT.		DWN SUBHASH. M 28AUG2020		
		CHK M. ZUCCA 28AUG2020		
		APVD PETER OTT 24NOV2020	NAME NECTOR T, 3Pos, SOCKET CONNECTOR CRIMP TYPE	
DIMENSIONS: mm		PRODUCT SPEC -	RESTRICTED TO -	
TOLERANCES UNLESS OTHERWISE SPECIFIED:		APPLICATION SPEC -	SCALE 2:1	
MATERIAL -		WEIGHT -	SIZE A300779	DRAWING NO C-2379239
FINISH -		CUSTOMER DRAWING	SHEET 1 OF 2	REV A

REVISIONS

P	LTR	DESCRIPTION	DATE	DWN	APVD
-	-	SEE SHEET 1	-	-	-

CRIMP TERMINATION
 REFER 114-133123 FOR DETAILED INSTRUCTION
 NOT TO SCALE

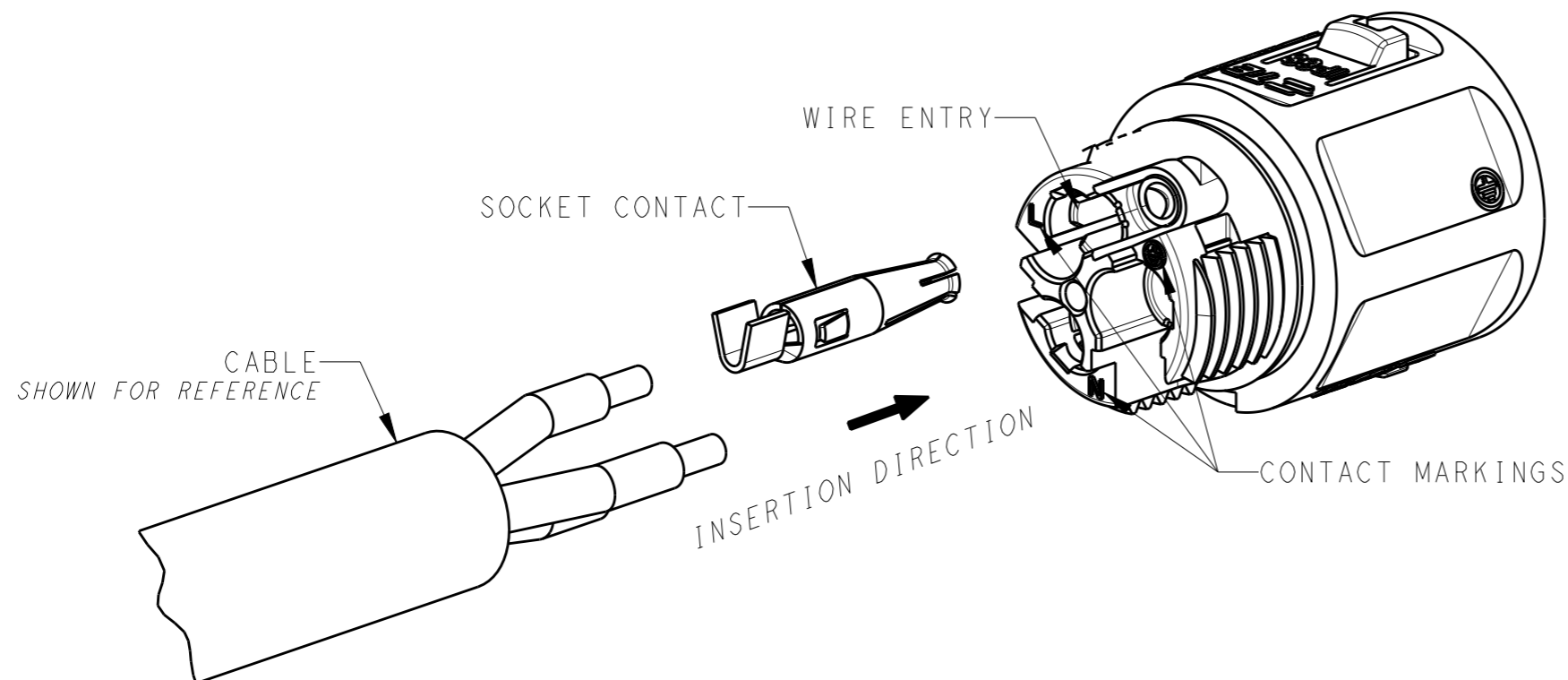

EXPLODED COMPONENTS
 NOT TO SCALE

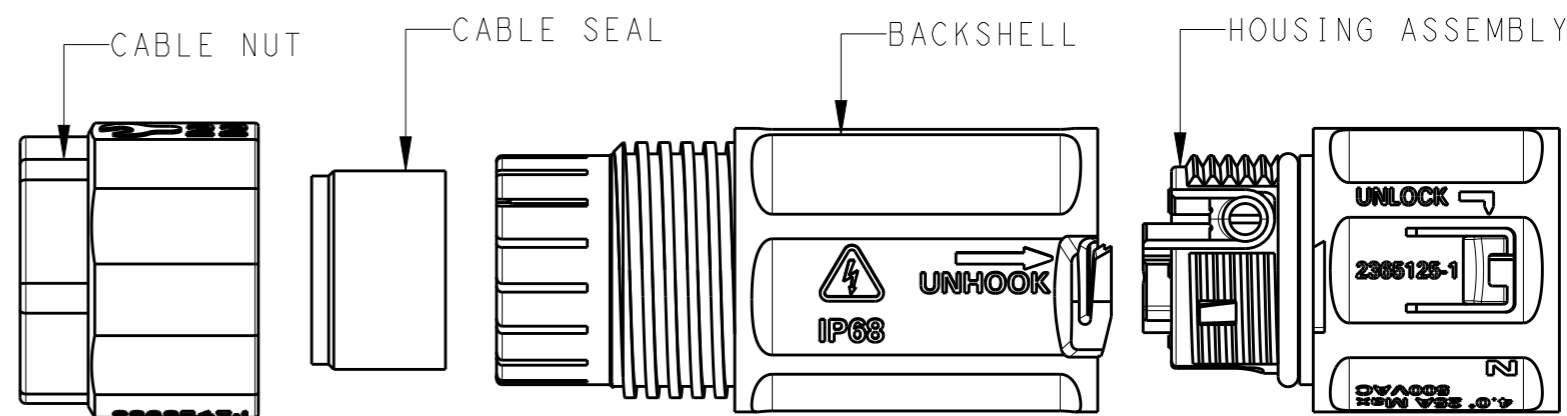

THIS DRAWING IS A CONTROLLED DOCUMENT.		DWN SUBHASH. M 28AUG2020	 TE Connectivity	
DIMENSIONS: mm		CHK M. ZUCCA 28AUG2020		
TOLERANCES UNLESS OTHERWISE SPECIFIED:		APVD PETER OTT 24NOV2020	NAME NECTOR T, 3Pos, SOCKET CONNECTOR CRIMP TYPE	
0 PLC ±0.2 1 PLC ±0.2 2 PLC ±0.1 3 PLC ± 4 PLC ± ANGLES ±1°		PRODUCT SPEC -	RESTRICTED TO	
MATERIAL -		FINISH -	APPLICATION SPEC -	SIZE A3
-		WEIGHT -	CAGE CODE 00779	DRAWING NO C-2379239
CUSTOMER DRAWING			SCALE 2:1	SHEET 2 OF 2
			REV A	