

Alternator Regulator with LIN

The 80310 is an integrated circuit intended to regulate the output voltage of an automotive alternator.

The IC supplies a current via a high side MOSFET to the excitation coil of the alternator and provides an internal freewheeling diode. It keeps the battery at its nominal charge and delivers current to electrical devices within the vehicle.

The 80310 also provides a load response control mechanism (LRC), and has an interface for the industry standard LIN protocol (Revision 1.3) to allow an ECU to control the regulated voltage and the LRC rate among other parameters. The ECU also can read back information about the status of the regulator and the alternator via LIN.

It can be programmed for most functions using OTP (Non-volatile Memory) and fit a large number of alternators and applications.

Features

- High side field driver
- Internal freewheeling diode
- Up to 8.0 A rotor current (excitation coil)
- Load response control (LRC)
- Thermal protection
- Thermal compensation
- LIN interface
- Set point voltage selectable from 10.6 to 16 V
- Rotor control and die temperature monitoring via LIN

80310

**AUTOMOTIVE ALTERNATOR
REGULATOR**

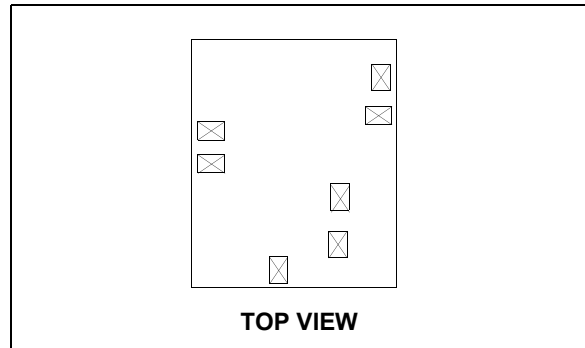

ORDERING INFORMATION

Device	Temperature Range (T _J)	Package
Devices part numbers are dependant on programming from factory.		
TO3 - Contact sales for information on limited engineering sample quantities. Production version is die sales only.		

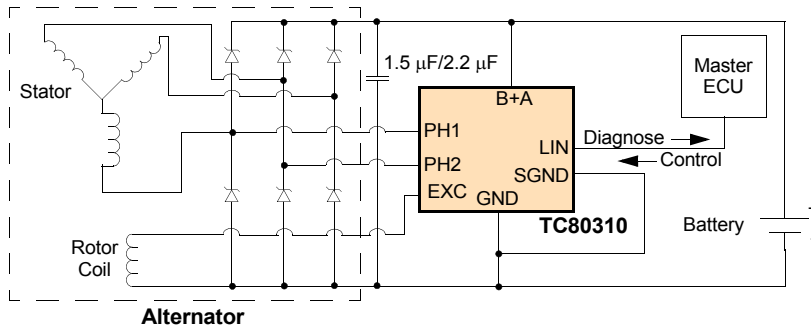

Figure 1. 80310 Simplified Application Diagram (LIN Mode)

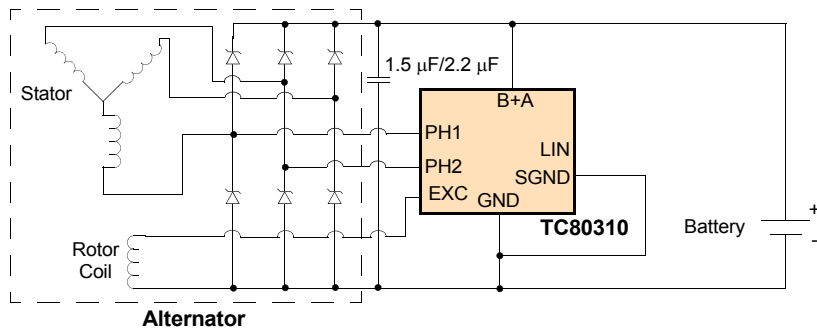

Figure 2. 80310 Simplified Application Diagram (Standalone, Self-start Mode)

* This document contains certain information on a new product. Specifications and information herein are subject to change without notice.

DEVICE VARIATIONS

Table 1. Version Determined Electrical Parameters

Version	Self-start	Self-start Threshold (RPM)	Phase sensitivity (V)	Default Regulation Voltage (V)	Fstart (RPM)	Fstop (RPM)	LRC Rate(s)	LRC disable (RPM)	Crest Regulation	BUS inactivity(s)	Default LIN Readout	Thermal Fault Threshold (°C)	Thermal Compensation threshold (°C)	Special LIN Feature	Alternat or pole-pair	Slave Address
	Active/ Not Active	3000/ 4000	0.45/0.9/ 1.35/1.8	13.5 to 15 (100 mV steps)	800/1050/ 1300/ 1550/ 1800/ 2050/ 2300/2500	500/ 650/ 850/ 1000	0/3/6.4/ 12.3	2400/ 3000/ 4000/ Never	Active / Not Active	1.31 / 3	T ⁹ /Current	135/145/ 150/160	135/145/150/ 160	Active/ Not Active	6/8	A/B
Versions																
TO3	Active	3000	0.45	14.3	800	500	3	3000	Not active	3	Current	145	145	Active	6	A
Devices part numbers are dependant on programming from factory.																
TC80310x WS	Various configurations are available and are programmable by OTP at the Freescale factory. Please contact your Freescale sales representative for further details, based on your system requirements, and solutions available.															

INTERNAL BLOCK DIAGRAM

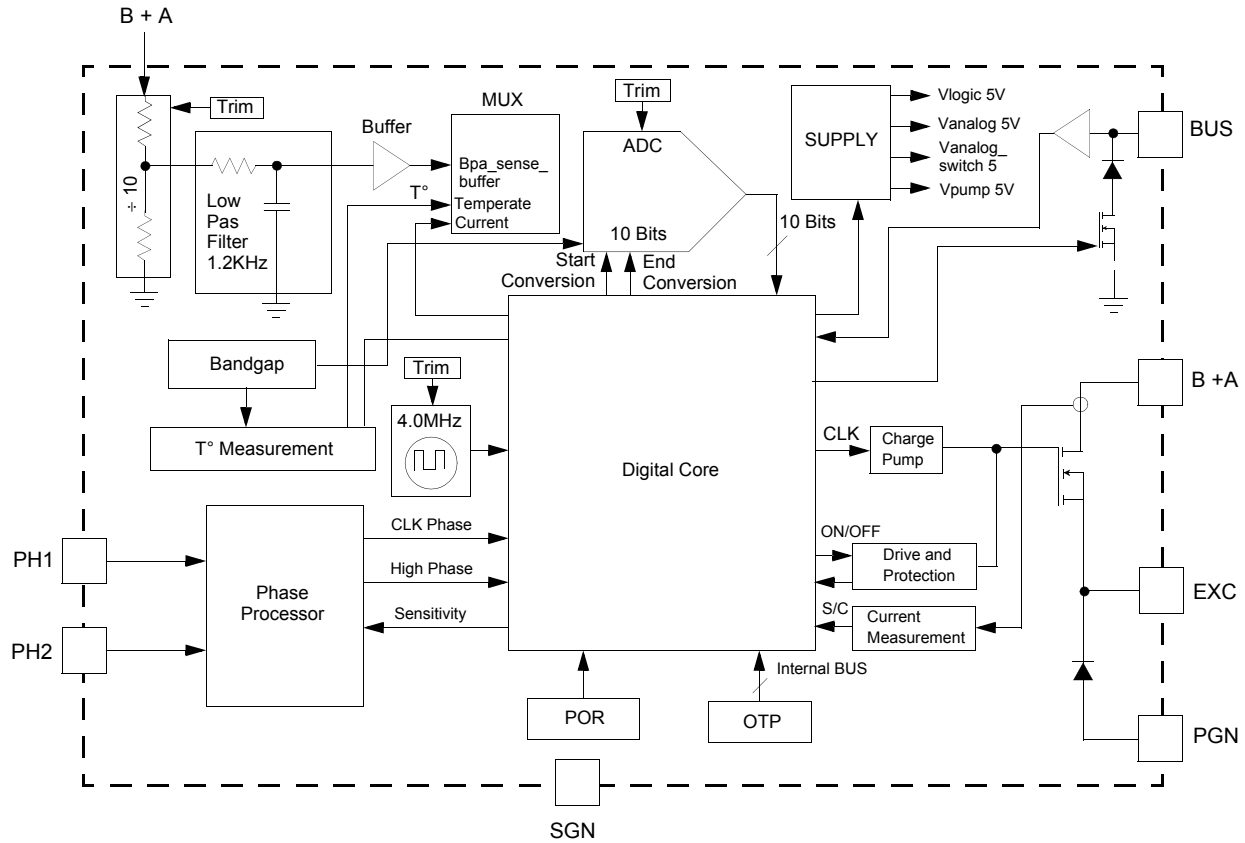

Figure 3. 80310 Simplified Internal Block Diagram

PIN CONNECTIONS

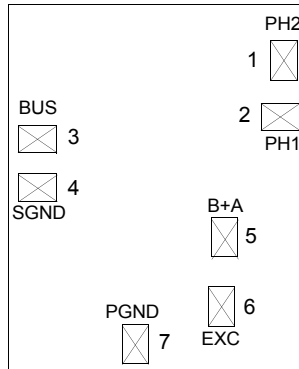

Figure 4. TC80310 Die Connections

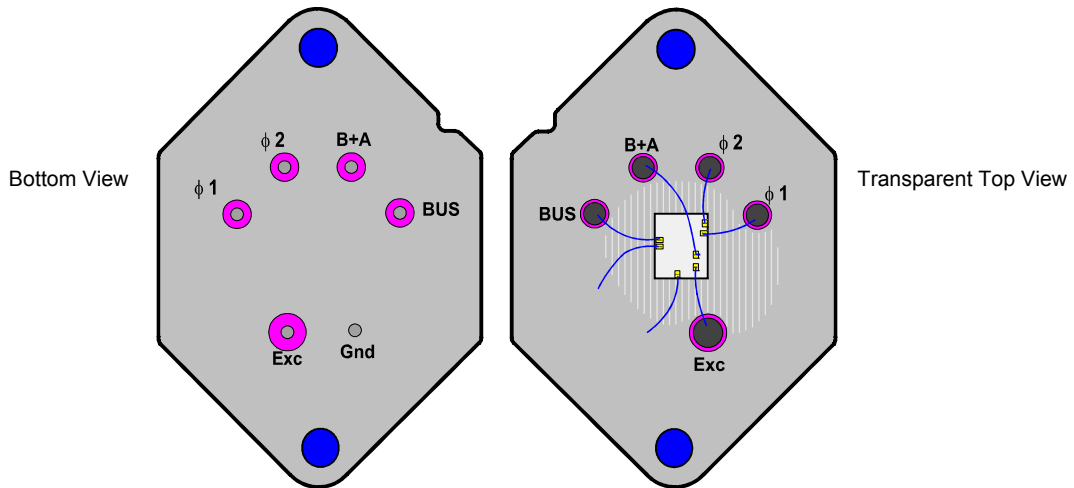

Figure 5. JTO3 Pin Connections (Sample Configuration Only) Non-production

Table 2. 80310 Pin Definitions

A functional description of each pin can be found in the Functional Pin Description section beginning on [page 9](#).

Pad Number TC80310	Pin Number TO3	Pin Name	Pin Function	Formal Name	Definition
1	1	PH2 ($\phi 2$)	Input	Phase 2	Signal from alternator phase 2
2	2	PH1 ($\phi 1$)	Input	Phase 1	Signal from alternator phase 1
3	3	BUS	Input/Output	LIN Bus	LIN connected to master
4	4	SGND	N/A	Signal Ground	Ground pin
5	5	B+A	Power	Supply Voltage	This pin is connected to the battery of the vehicle
6	6	EXC	Output	Excitation	This pin is connected to the rotor coil of the alternator
7	7	PGND	N/A	Power Ground	Ground termination

ELECTRICAL CHARACTERISTICS

MAXIMUM RATINGS

Table 3. Maximum Ratings

All voltages are with respect to ground unless otherwise noted. Exceeding these ratings may cause a malfunction or permanent damage to the device. $T_A = 25\text{ }^\circ\text{C}$, unless otherwise stated.

Ratings	Symbol	Value	Unit
ELECTRICAL RATINGS			
B+A Supply Pin			
DC Voltage	V_{B+CONT}	27	V
Load Dump Transient Voltage (ISO7637-2)	$V_{B+TRANS}$	40	V
Maximum Reverse B+A Voltage ⁽¹⁾ (5 seconds)	V_{-B+A}	-2.4	V
Maximum Excitation Current at $T_J = 150\text{ }^\circ\text{C}$ ⁽²⁾	I_{EXC}	5.0	A
Maximum Excitation Current at $T_J = 25\text{ }^\circ\text{C}$	I_{EXC}	8.0	A
Recirculation Diode Peak Current		8.0	A
Recirculation Diode Reverse Voltage		40	V
PHASE Input Voltage Range	V_{PHASE}	± 40	V
BUS Pin Input Range		-2.0 to +40	V
ESD Voltage ⁽³⁾			V
Human Body Model - All Pins (MIL std 883C) ⁽⁴⁾	V_{ESD1}	± 6000	
Machine Model - All Pins	V_{ESD2}	± 200	
Accessible Pins (EN61.000-4-2) When Mounted on the Alternator (BUS & B+A) by Contact Discharge	V_{ESD3}	± 8000	
Air Discharges When Mounted on the Alternator ⁽⁵⁾	V_{ESD4}	± 15000	
Standard Transient Pulses ISO7637-1 & -3	Level	150	V
THERMAL RATINGS			
Storage Temperature	T_{STOR}	-45 to +150	$^\circ\text{C}$
Operating Junction Temperature ⁽⁶⁾	T_J	-40 to +150	$^\circ\text{C}$
Thermal Shutdown Temperature	T_{J-TSD}	185	$^\circ\text{C}$
Thermal Shutdown Hysteresis	$T_{TSD-HYST}$	10	$^\circ\text{C}$

Notes

- Not tested. Depends on package and bonding.
- Characterized at $150\text{ }^\circ\text{C}$ but not production tested
- Testing is performed in accordance with the Human Body Model ($C_{ZAP} = 100\text{ pF}$, $R_{ZAP} = 1500\ \Omega$), Charge Device Model, Robotic ($C_{ZAP} = 4.0\text{ pF}$), or the EN61000-4-2 specification ($C_{ZAP} = 150\text{ pF}$, $R_{ZAP} = 330\ \Omega$).
- Except Phase1 and Phase2 ($\pm 5000\text{ V}$)
- Product Powered. ESD done on pulley, B+ and metal alternator case ($C_{ZAP} = 330\text{ pF}$, $R_{ZAP} = 2.0\text{ k}\Omega$)
- Guaranteed by Design.

STATIC ELECTRICAL CHARACTERISTICS

Table 4. Static Electrical Characteristics

Electrical parameters are tested at die level from 30 to 140 °C. Typical values noted reflect the approximate parameter mean at $T_A = 25$ °C under nominal conditions, unless otherwise noted. Parametric guaranteed from $T_J = -40$ to 150 °C, unless otherwise noted. Operation is guaranteed by design up to T_{J-TSD} .

Characteristic	Symbol	Min	Typ	Max	Unit
Operating Voltage, V_{B+A}	V_{B+A}	8.0	—	27	V
Bus Operating Voltage (LIN)	V_{BUS}	8.0	—	18	V
Quiescent Current at $V_{B+A}=12.5$ V (Phases at 0 V) (including phase currents at 25 °C)	$I_{SB2.B+A-0}$	—	—	110	μ A
Quiescent Current at $V_{B+A}=12.5$ V (Phases at 12.5 V) (including phase currents at 25 °C)	$I_{SB2.B+A-1}$	—	—	250	μ A
Operating Current no EXC Load at 25 °C and $V_{B+A} = 13$ V	I_{OP}	—	12	16	mA
Range of Regulation Voltage (50% DC)	V_{REG}	10.60	—	16.0	V
V_{REG} Setting Accuracy Voltage at 50% for $V_{REG} = 13.8$ V and $T_J = 25$ °C	ΔV_{REG1}	-100	—	+100	mV
V_{REG} Setting Accuracy Voltage at 50% for $V_{REG} = 10.7$ V and $V_{REG} = 16$ V and $T_J = 25$ °C	ΔV_{REG2}	-150	—	+150	mV
Load Dump Detection Threshold Voltage	V_{LD}	—	21	—	V
ΔV_{REG} with Load Voltage ⁽⁷⁾	ΔV_{REG-L}	-150	—	0	mV
ΔV_{REG} with Speed Voltage ⁽⁸⁾	ΔV_{REG-S}	-100	—	100	mV
R_{DS-ON} FIELD TMOS at $I_{EXC} = 5.0$ A and $T_J = 140$ °C ⁽⁹⁾	$R_{DS.ON.EXC}$	—	—	100	$m\Omega$
Over-voltage Detection ⁽¹⁰⁾	$V_{EXC.SEN}$	0.3	0.6	1.0	V
Recirculation Diode Voltage at 5.0 A (Excitation Current)	V_F	—	1.2	1.5	V
Phase Input High Threshold Voltage (PHASE OK)	V_{P-H}	—	8.0	—	V
Phase Input High Hysteresis Voltage (PHASE OK)	$V_{PH-HYST}$	—	1.0	—	V
Over-voltage (Fault) Threshold Voltage	V_{OV}	16.2	16.5	—	V
EXC Short-circuit Protection Threshold ⁽¹¹⁾	I_{EXC-SC}	—	10	—	A
LIN Peak Short-circuit Current	I_{LIN-SC}	—	62	150	mA

Notes

7. Changing load from 5% to 90% of alternator capability.
8. At low load (5%) and varying alternator speed from 2000 RPM to 18000 RPM. By design, not tested.
9. The thermal capability of the packaging is critical to the full use of the output drive.
10. If there is a high voltage and the EXC pin is above this voltage a fault is detected.
11. Pulsed at low duty cycle.

Table 4. Static Electrical Characteristics

Electrical parameters are tested at die level from 30 to 140 °C. Typical values noted reflect the approximate parameter mean at $T_A = 25$ °C under nominal conditions, unless otherwise noted. Parametric guaranteed from $T_J = -40$ to 150 °C, unless otherwise noted. Operation is guaranteed by design up to T_{J-TSD} .

Characteristic	Symbol	Min	Typ	Max	Unit
Bus Voltage Low Level Receive (LIN) ⁽¹²⁾	$V_{BUS-LOW-REC}$	—	—	$0.3 * V_{B+A}$	V
Bus Voltage Low Level Send (LIN) ⁽¹²⁾	$V_{BUS-LOW-SEND}$	—	—	1.4	V
Bus Voltage High Level Receive (LIN) ⁽¹²⁾	$V_{BUS-HIGH-REC}$	—	—	$0.7 * V_{B+A}$	V
Bus Voltage High Level Send (LIN) ⁽¹²⁾	$V_{BUS-HIGH-SEND}$	6.4	—	—	V
Emergency Regulation Voltage ⁽¹³⁾	V_{VCCLB}	—	8.5	9.5	V

Notes

12. Referred to regulator/alternator ground.
13. Operates asynchronous to the regulation cycle in case of a very rapid drop in B+A, usually caused by adding a heavy load without a battery in the system.

DYNAMIC ELECTRICAL CHARACTERISTICS

Table 5. Dynamic Electrical Characteristics

Electrical parameters are tested at die level from 30 to 140 °C. Typical values noted reflect the approximate parameter mean at $T_A = 25\text{ °C}$ under nominal conditions, unless otherwise noted. T_J from -40 to 150 °C, unless otherwise noted. Operation is guaranteed by design up to T_{J-TSD} .

Characteristic	Symbol	Min	Typ	Max	Unit
Regulation Frequency	F_{REG}	106	122	137	Hz
Phase Noise Rejection Filter	t_{LPH}	—	12.5	—	μs
Fault Qualification Delay/Filter ⁽¹⁴⁾	t_{FAULT}	—	400	—	ms
Bus Signal Risetime (LIN) From 20% to 80% of V_{BUS} with $V_{B+A} = 18\text{ V}$	t_{RISE}	5.0	—	40	μs
Bus Signal Falltime (LIN) From 20% to 80% of V_{BUS} with $V_{B+A} = 18\text{ V}$	t_{FALL}	3.5	—	40	μs
Minimum Duty Cycle	DC_{MIN}	—	4.1	—	%
Start-up Duty Cycle	$DC_{STARTUP}$	—	13.5	—	%
Delta LRC Duty Cycle	ΔLRC	—	3.125	—	%

Notes

14. A fault has to be present for the entire time before it is considered valid.

FUNCTIONAL DESCRIPTION

INTRODUCTION

The 80310 is an integrated circuit intended to regulate the output voltage of an automotive alternator.

The IC supplies a current via a high side MOSFET to the excitation coil of the alternator and provides an internal freewheeling diode. It keeps the battery at its nominal charge and delivers current to electrical devices within the vehicle.

The 80310 also provides a load response control mechanism (LRC), and has an interface for the industry standard LIN protocol (v1.3) to allow an ECU (master) to control the regulated voltage and the LRC rate among other parameters.

The ECU also can read back information about the status of the regulator and the alternator via LIN.

The programmable parameters by the ECU:

- Regulated voltage
- LRC ramp time, LRC cut off
- Excitation current limitation

The information sent back to the ECU:

- Die temperature
- Excitation current
- EXC duty cycle (DF)
- Manufacturer and class
- Faults:
 - Electrical, mechanical, temperature
 - LIN time out
 - LIN communication error: watchdog, check sum, Id parity, sync break

The IC can be programmed as an OTP device (One Time Programmable) to fit a large number of alternators and applications. These programmable parameters are described in the functional device operation (Table 6). This circuit is specially designed to operate in harsh automotive environment.

FUNCTIONAL PIN DESCRIPTION

PHASE (PH1 AND PH2)

These pins connect to stator windings. These signals are used for the rotor speed measurement, stator voltage measurement as well as the self start detection.

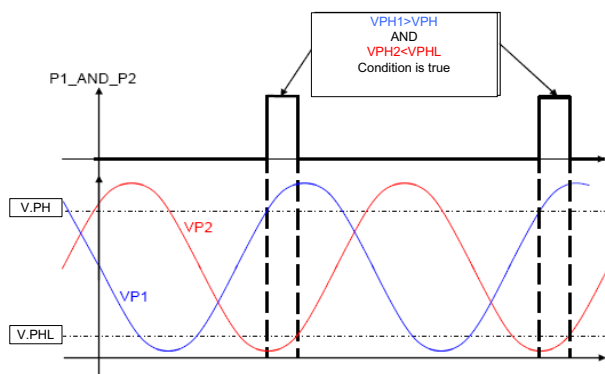

Figure 6. Internal Signals in Normal Mode

In this situation the regulator stays in Normal mode. (P1 and P2 represent internal signals coming from the phase processor block, which are routed to the logic block).

LIN BUS (BUS)

This LIN pin represents the single-wire bus transmitter and receiver. It is suited for automotive bus systems and is based on the LIN bus specification v1.3.

GROUND PINS (PGND, SGND)

The 80310 has two different types of ground pins. The PGND pin is the power ground pin for the device. The SGND is the signal ground pin.

Important: The PGND, the SGND pins must be connected together to a ground external to the device.

SUPPLY VOLTAGE (B+A)

The 80310 is supplied by this B+A pin. This voltage is also used as the feedback voltage by the control circuit.

EXCITATION (EXC)

This pin is connected to the excitation coil (rotor) of the alternator. The IC supplies a current via a high side MOSFET to the excitation winding to create a magnetic field in the rotor. This generates sinusoidal currents in the stator which are rectified by a diode bridge.

FUNCTIONAL INTERNAL BLOCK DESCRIPTION

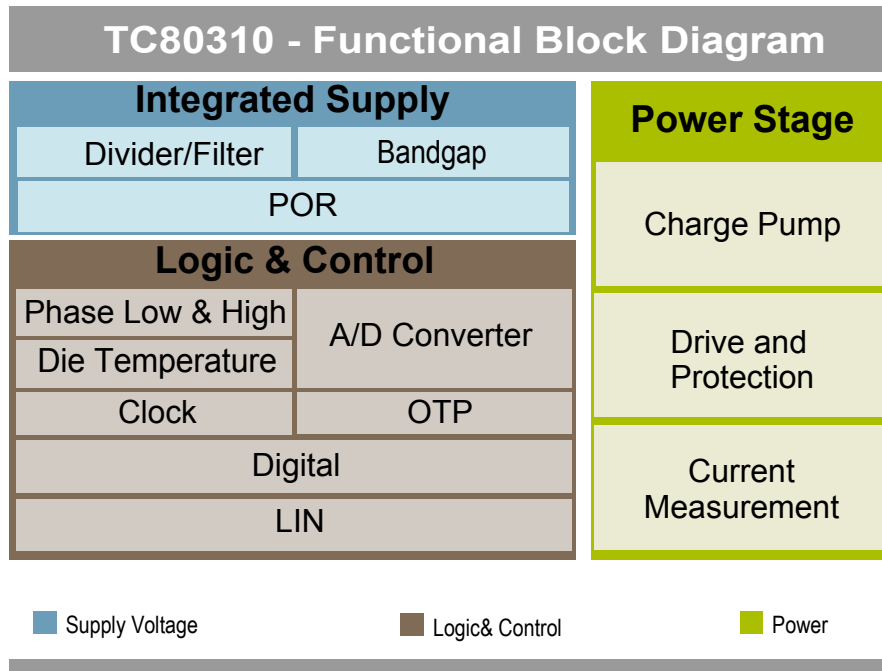

Figure 7. Functional Internal Block Diagram

SUPPLY VOLTAGE: FILTER/DIVIDER, BANDGAP, AND POR

An input filter and divider provides a clean image of the battery to the digital regulation loop circuit. The divider ratio can be adjusted by OTP.

The supply block provides the voltages for the internal blocks of the 80310:

- Main logic
- Analog permanently powered or not
- LIN transceiver
- Charge pump

The purpose of the POR block is to generate a clean power-on signal to the main logic.

The Bandgap block provides the voltage and current references for the other blocks.

POWER STAGE: CHARGE PUMP, DRIVE AND PROTECTION, CURRENT MEASUREMENT

The power stage of the circuit consists of the gate driver with a charge pump and protection to control a low side driver switching the excitation current. A short-circuit is instantaneously detected and the excitation current is turned off until the next regulation cycle. A freewheeling diode is inserted between the EXC and GND pins, across the excitation coil for the energy recirculation.

The current measurement block provides a proportional value of the excitation current flowing in the high side switch.

LOGIC AND CONTROL:

DIGITAL

The digital block gathers all the digital functions of the device. The main functionality is described in the device operation paragraph.

CLOCK

This block is the clock reference for the digital block. The oscillator generates a 5.0 V square wave at the frequency of 4.0 MHz in Normal mode operation.

OTP

This block allows an easy configuration and adjustment of the circuit. A set of NVM bits can be programmed during the factory test phase. They are described in [Table 6](#).

PHASE LOW & HIGH

The phase detector monitors the Phase inputs and sends filtered low and high levels to the main logic when either one has reached the detection level (1.0 V at startup and 8.0 V afterwards).

ADC

The analog to digital converter is used in the voltage regulation loop, in the current feedback and in temperature measurement.

LIN

This block allows the LIN bus transmission and reception.

digital number to be transmitted via the LIN bus to the controller.

T° MEASUREMENT

This block generates a voltage proportional to the die temperature. This voltage is converted by the ADC into a

POWER ON RESET (POR):

When a Power On Reset occurs, product internal registers are reset and the product goes into standby mode.

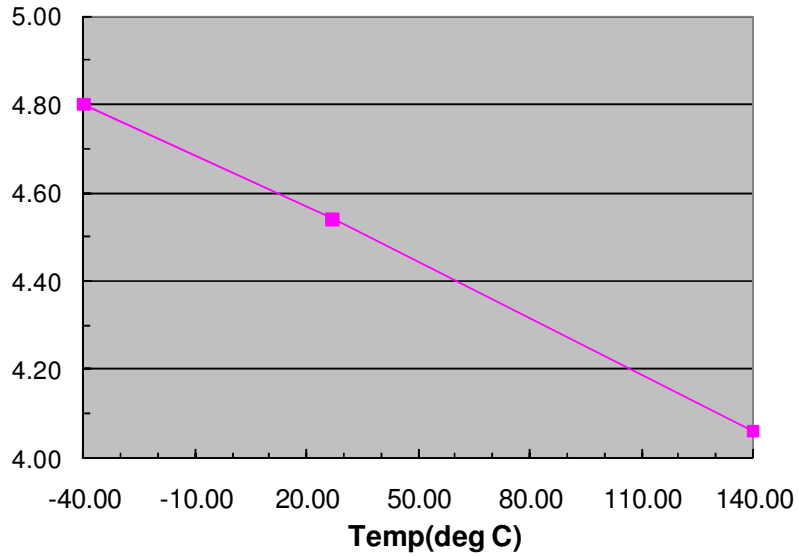

FUNCTIONAL DEVICE OPERATION

OPERATIONAL MODES

The following figure describes the battery operating voltage.

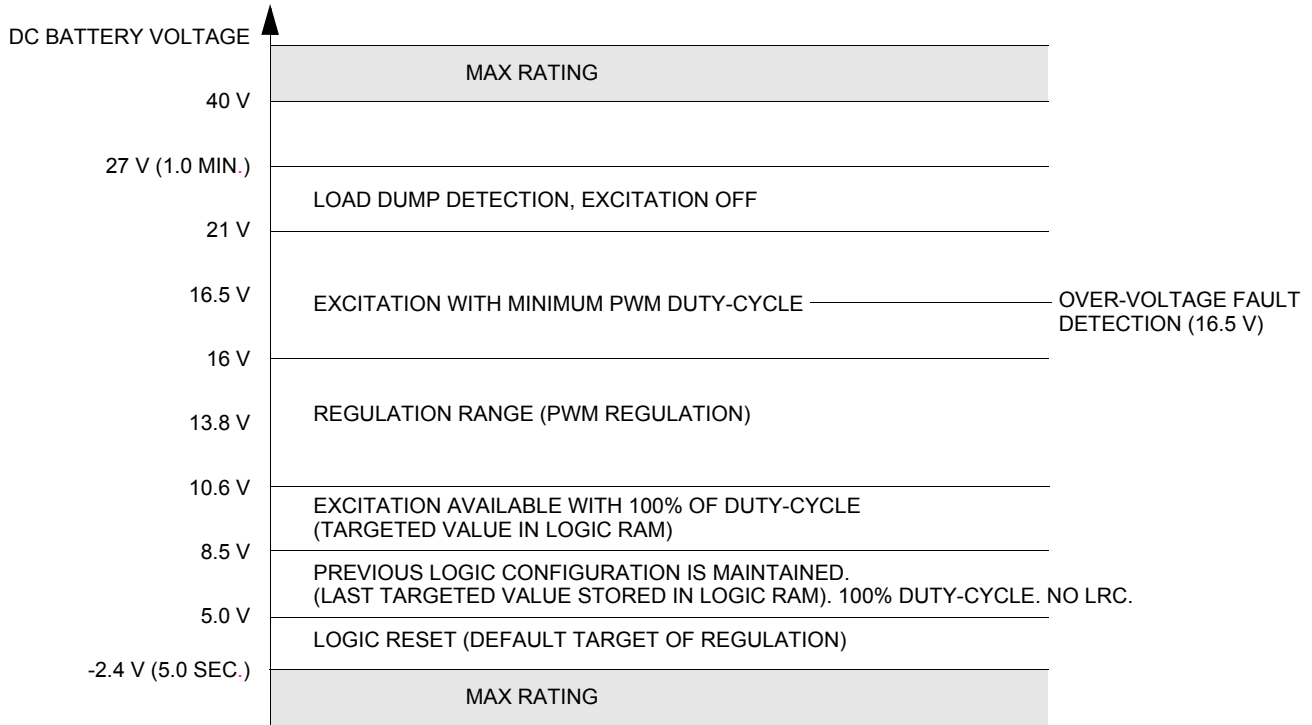

Figure 8. Battery Operating Voltage Range

LOGIC COMMANDS AND REGISTERS

This IC is One Time Programmable (OTP), during the final test phase, in the factory. The OTP Programmable Options table ([Table 6](#)) describes the programmable functions that

are selectable by the customer. These Non-volatile Memory (NVM) bits are not alterable after the OTP operation at the factory.

Table 6. OTP Programmable Options

Function	OTP Bits	Comments.
Default Regulation Voltage	4	13.5 to 15 V, 100 mV steps
Phase Start Regulating RPM ⁽¹⁵⁾ , f_{START}	3	800 - 2500 RPM, 8 possible values (800, 1050, 1300, 1550, 1800, 2050, 2300, 2500)
Phase Stop Regulating RPM ⁽¹⁵⁾ , f_{STOP}	2	500, 650, 850, 1000 RPM
LRC Disable RPM Default ⁽¹⁵⁾ , f_{LRC}	2	2400, 3000, 4000 RPM & never
LRC Rate	2	0, 3.0, 6.4 & 12.3 seconds
Alternator Pole-pairs	2	6, 7, 8 & 9
Slave Address	1	Two address options, A or B
Phase Sensitivity (Startup)	2	0.45 V, 0.9 V, 1.35 V, 1.8 V ⁽¹⁶⁾
Self-start (Auto-amorçage)	1	Yes or No.
Self-start Threshold	2	3000, 4000 RPM
Bus Inactivity or Data Corruption Timeout	1	1.31 or 3 seconds
Default LIN Readout Temp or EXC Current	1	Select Temperature or Current
Thermal Fault Threshold	2	135 °C, 145 °C, 150 °C, 160 °C
Thermal Compensation Threshold	2	135 °C, 145 °C, 150 °C, 160 °C
Low Voltage Threshold	1	75% of the target regulation voltage or none
Alternator Supplier and Class	3+5	Alternator Information.
Crest Regulation	1	Enabled or disabled
Parity Bit	1	Data Protection
Special LIN Features, nvm-lin-special, LIN com with global ID (2B+3C)	1	Enabled or Disabled
Security "lock bits"	1	EOL

Notes

15. These are adjustable independently, the IC internally compensates for the pole-pairs if the correct OTP setting is made. Frequency measurements are made over multiple cycles (8) for greater accuracy.
16. Typical values at room temp (30 °C)

STATE MACHINE

The following diagram describes the state machine of the TC80310:

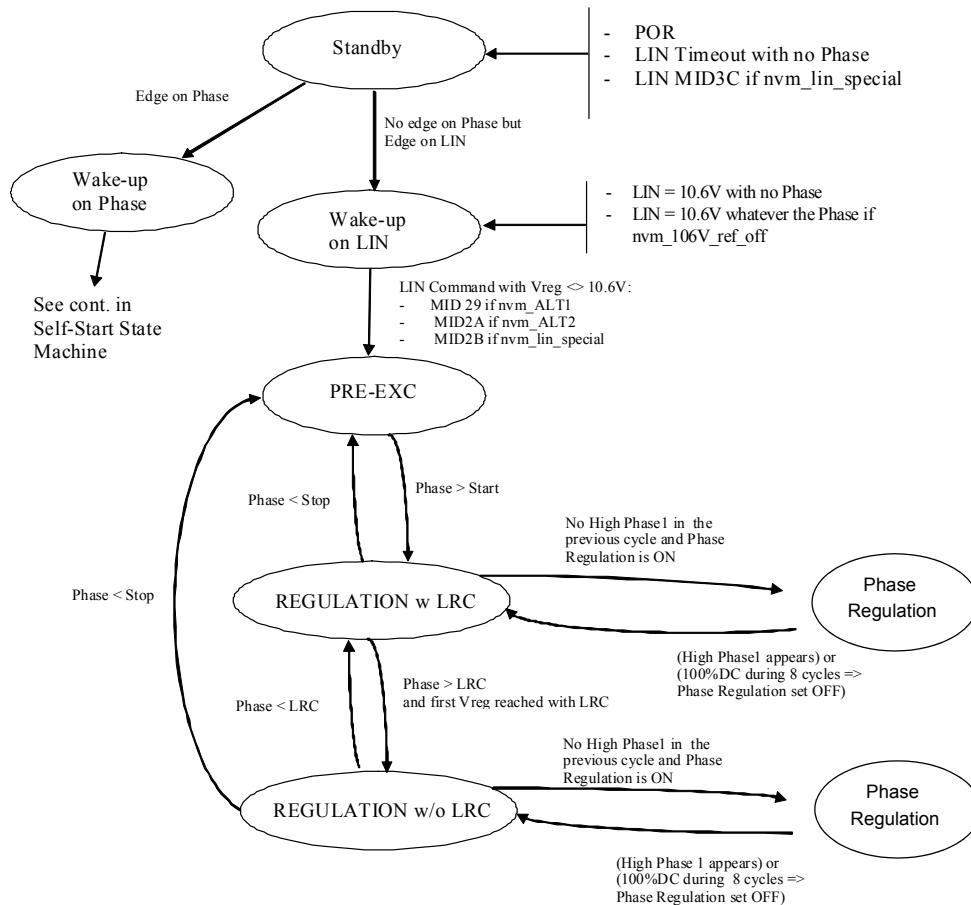

Figure 9. LIN Wake-up State Machine

STANDBY:

The 80310 is in standby mode, if there is a LIN timeout and in absence of alternator rotation (no phase), or in case of power and reset (POR), or with a LIN MID3C command if `nvm_lin_special` is set

- There is no excitation.
- The duty cycle (DC) is equal to zero.

The device needs a small amount of quiescent current to feed some functions such as oscillator.

LIN timeout means:

- No activity on the LIN bus during a specified time
- or on a LIN watchdog timeout during a specified time

WAKE-UP:

This state is reached when a transition is detected on the communication interface.

- The logic is out of reset.
- All the blocks are on.
- There is no regulation. DC = 0%

After a LIN timeout, if no valid instruction is decoded, then the device goes back into Stand-by mode.

PRE-EXC:

The pre-excitation state is reached as soon as a valid instruction for the regulated value (V_{REG}), different from 10.6 V, is decoded.

If $B+A$ is lower than the expected (V_{REG}), then the duty cycle is equal to $DC_{STARTUP}$, or else DC_{MIN} .

The purpose of pre-excitation is to increase the magnetization of the alternator, to guarantee a minimum phase voltage for the rotor speed measurement when the engine starts.

The pre-excitation stays active until the detection of phase starts regulating RPM (f_{START}).

REGULATION WITH LRC:

In this mode, the 80310 regulates the alternator output to the set reference level. The excitation is controlled by LRC if this LRC mode is active until the detection of phase stop This

LRC mode is active until the detection of phase stop regulating RPM (f_{STOP}). In this case, the device goes back to the pre-excitation mode. If the phase frequency reaches the LRC disable RPM default (f_{LRC}), the device goes into regulation without LRC.

REGULATION WITHOUT LRC:

This mode is active when the phase frequency is above the LRC disable RPM default (f_{LRC}), the first V_{REG} was reached with LRC.

The excitation is controlled only by the internal comparator of $B+A$ and V_{REG} . The DC can not be lower than DC_{MIN} .

If the phase frequency goes below the LRC disable RPM default (f_{LRC}), then the 80310 comes back to the regulation

with LRC mode. If the phase frequency goes below the phase stop regulating RPM, the device goes to pre-excitation mode.

RE-REGULATION:

The excitation is forced to 100%. This mode is active if there is no high phase on non active phase ($PHx < V_{PH}$) in the previous cycle, until the high phase comes back. At the end of the 8th cycle, if there is still no high phase, the regulation mode is set off and the device goes back to the regulation mode with or without LRC.

$B+A$ is lower than V_{REG} . In any case, DC cannot be lower than DC_{MIN} .

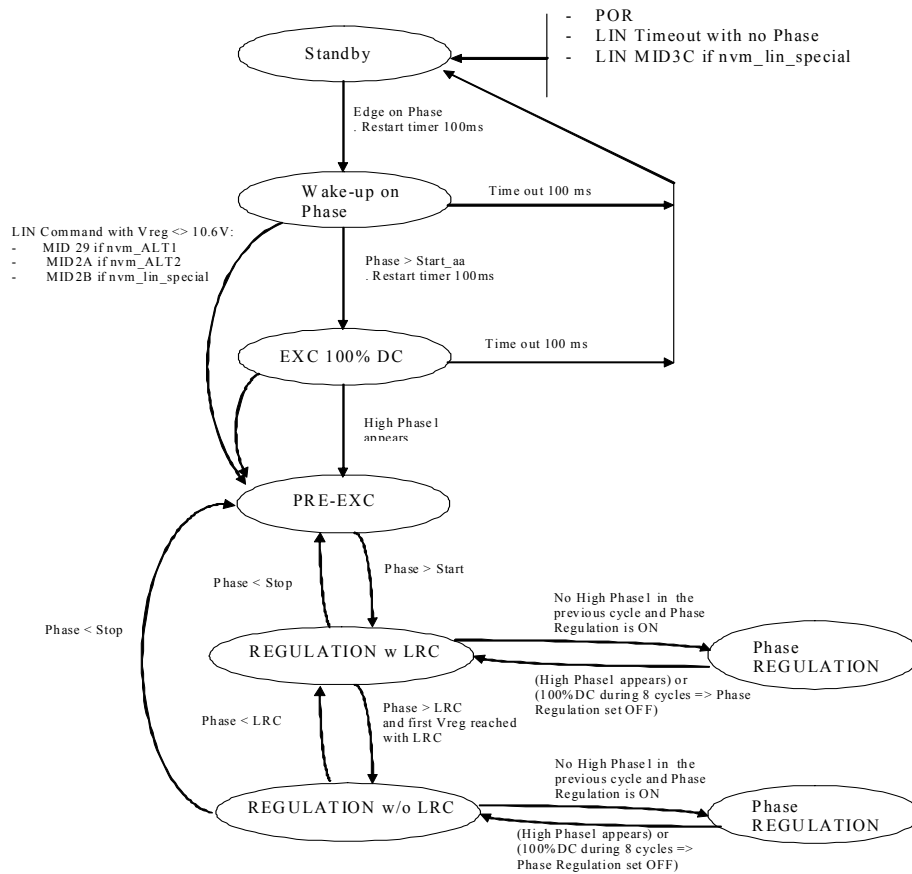

Figure 10. Self-start State Machine

This state machine runs only if self-start option has been programmed.

STANDBY:

The 80310 is in Standby mode if there is a LIN timeout, and in absence of alternator rotation (no phase), if power and reset (POR), or with a LIN MID3C command, if nvm_lin_special is set.

- There is no excitation
- The duty cycle (DC) is equal to zero

The device needs a small amount of quiescent current to feed some functions such as oscillator.

LIN timeout means:

- No activity on the LIN bus during a specified time
- or on a LIN watchdog timeout during a specified time

WAKE-UP:

This state is reached when an edge is detected on the phase (Phase voltage > Phase sensitivity)

- The logic is out of reset

- All the blocks are on
- There is no regulation. DC=0%

After a 100 ms timeout, if the speed has not reached f_{START} , then the device goes back to Standby mode.

EXCITATION 100% DC:

When the speed has reached Start_aa, then the device goes into this state until the high phase appears, or during a 100 ms maximum.

- The logic is out of reset.
- All the blocks are on.
- There is no regulation. DC = 100%

Start_aa (see [Table 1](#)): is a special threshold for the self-start when it is in Wake-up mode, before going in EXC 100% DC, waiting for high phase. Once high phase appeared the state machine is exactly the same as with LIN wake-up

Start_aa can be programmed at 3000 rpm or 4000 rpm.

REGULATION WITH LRC:

In this mode, the 80310 regulates the alternator output to the set reference level. The excitation is controlled by LRC, if B+A is lower than V_{REG} . DC can not be lower than DC_{MIN} .

This LRC mode is active until the detection of phase stop regulating RPM (f_{STOP}). In this case, the device goes back to the Pre-excitation mode. If the phase frequency reaches the LRC disable RPM default (f_{LRC}), the device goes into regulation without LRC.

REGULATION WITHOUT LRC:

This mode is active when the phase frequency is above the LRC disable RPM default (f_{LRC}), the first V_{REG} was reached with LRC.

The excitation is controlled only by the internal comparator of B+A and V_{REG} . The DC can not be lower than DC_{MIN} .

If the phase frequency goes below the LRC disable RPM default (f_{LRC}), then the 80310 comes back to the regulation with LRC mode. If the phase frequency goes below the phase stop regulating RPM, the device goes to Pre-excitation mode.

RE-REGULATION:

The excitation is forced to 100%. This mode is active if there is no high phase on non active phase ($PHx < V_{PH}$) in the previous cycle, until the high phase comes back. At the end of the 8th cycle, if there is still no high phase, the regulation mode is set to off and the device goes back to the regulation mode, with or without LRC.

LIN BUS INFORMATION:

The operational control and programming, required in the end application, is carried out through the LIN interface. Refer to [Tables 7](#) to [15](#).

The regulator shall only give pre-excitation when it receives a LIN command targeted for it, the shutdown command is the code that would otherwise set 10.6 V ("000000").

LIN addresses are listed in MID format, [Table 8](#), while the data fields are listed in [MSB:LSB] format

[Table 10](#) lists the values for the Target/Programmed Regulated voltage contained in the Alternator A/B write data field (ID=29, 2A), byte 1.

[Table 11](#) lists the values for the LRC Ramp Time and Ramp Cut-off contained in the Alternator A/B write data field (ID=29,2A), byte 2.

[Table 12](#) lists the values for the die Temperature contained in the Alternator A/B read data field (ID=11, 13), byte 2.

[Table 13](#) lists the values for the alternator Excitation Current contained in the Alternator A/B read data field (ID=11, 13), byte 2, as well as the Excitation duty cycle contained in the Alternator A/B read data field (ID=11, 13), byte 1.

[Table 14](#) lists values for the excitation Current Limit contained in the Alternator A/B write data field (ID=29, 2A), byte 3.

[Table 15](#) lists the values for the alternator Manufacturer and Class code contained in the Alternator A/Bread data field (ID=12, 14), byte 1.

COMMAND TABLES

Table 7. LIN Command Information

Function	LIN	Active Bits
V _{REG} Digital	W	6
LRC Rate	W	4
LRC Disable Frequency	W	4
Excitation Current Limitation (0 A to 7.75 A)	W	5
Status & Diagnostic	R	5
EXC Duty-Cycle	R	5
Excitation Current	R	6 ⁽¹⁷⁾
Die Temperature	R	6 ⁽¹⁸⁾
Manufacturing Information	R	8

Notes

17. This information is given as 6 bits and is only accurate:

a) from 0 °C to 25 °C:

- from 0 A to 3.875 A: +/- 375 mA

- from 3.875 A to 7.75 A: +/- 10%

b) outside the previous temperature range:

- from 0 to 3.875 A: +/-625 mA

- from 3.875 A to 7.75 A: +/-15%

Currents higher than 7.75 A, which may be possible at low temperature, are reported as 7.75 A. Excitation Current and Die Temperature functions are exclusive.

18. This gives a resolution of 3.5 degrees and the accuracy is +/-10 degrees. Excitation Current and Die Temperature functions are exclusive.

Table 8. LIN Byte/Direction Data Format

MID (hex) ID [5:1]	Bytes	Direction ⁽¹⁹⁾	Message Name
ALTERNATOR A			
29	4	M to S	Write Regulator Control Data to Alt. A
11	2	S to M	Read Regulator Status 2 Bytes from Alt. A
12	2	S to M	Read Regulator Identifier 2 Bytes from Alt. A
ALTERNATOR B			
2A	4	M to S	Write Regulator Control Data to Alt. B
13	2	S to M	Read Regulator Status 2 Bytes from Alt. B
14	2	S to M	Read Regulator Identifier 2 Bytes from Alt. B
GLOBAL			
2B	4	M to S	Write Regulator Control Data to Alt. A and Alt. B
3C	4	M to S	Global Sleep Command (first byte 0x00)

Notes

19. M to S = Master to Slave; S to M = Slave to Master

Table 9. LIN Read/Write Data Format

**ALTERNATOR A
 DATA FIELD DESCRIPTION FOR ALTERNATOR A WRITE COMMAND: ID = 29**

7	6	5	4	3	2	1	0
BYTE 1							
x	x	Target Voltage [5:0]					
BYTE 2							
Ramp Cutoff [3:0]				Ramp Rate [3:0]			
BYTE 3							
x	x	x	x	Current Limit [4:0]			
BYTE 4							
x	x	x	x	x	x	x	x

**ALTERNATOR A
 DATA FIELD DESCRIPTION FOR ALTERNATOR A READ COMMAND: ID = 11**

7	6	5	4	3	2	1	0
BYTE 1							
EXC Duty Cycle [4:0]					F_EL	F_MEC	F_HT
BYTE 2							
LIN Bus Timeout	Com error	Measured Current or Temperature [5:0]					

**ALTERNATOR A
 DATA FIELD DESCRIPTION FOR ALTERNATOR A READ COMMAND: ID = 12**

7	6	5	4	3	2	1	0
BYTE 1							
Class[4:0]					Manufacturer [2:0]		
BYTE 2							
0	0	0	0	Slave Not Responding	Checksum	ID Parity Fault	Sync Break Fault

**ALTERNATOR B
 DATA FIELD DESCRIPTION FOR ALTERNATOR B WRITE COMMAND: ID = 2A**

7	6	5	4	3	2	1	0
BYTE 1							
x	x	Target Voltage [5:0]					
BYTE 2							
Ramp Cutoff [3:0]				Ramp Rate [3:0]			
BYTE 3							
x	x	x	x	Current Limit [4:0]			
BYTE 4							
x	x	x	x	x	x	x	x

Table 9. LIN Read/Write Data Format

7	6	5	4	3	2	1	0
ALTERNATOR B							
DATA FIELD DESCRIPTION FOR ALTERNATOR B READ COMMAND: ID = 13							
BYTE 1							
EXC Duty Cycle [4:0]					F_EL	F_MEC	F_HT
BYTE 2							
LIN Bus Timeout	Com error	Measured Current or Temperature [5:0]					
ALTERNATOR B							
DATA FIELD DESCRIPTION FOR ALTERNATOR B READ COMMAND: ID = 14							
7	6	5	4	3	2	1	0
BYTE 1							
Manufacturer [2:0]			Class[4:0]				
BYTE 2							
0	0	0	0	Slave Not Responding	Checksum	ID Parity Fault	Sync Break Fault
GLOBAL							
DATA FIELD DESCRIPTION FOR ALTERNATOR A+B WRITE COMMAND: ID = 2B⁽²⁰⁾							
7	6	5	4	3	2	1	0
BYTE 1							
x	x	Target Voltage [5:0]					
BYTE 2							
Ramp Cutoff [3:0]				Ramp Rate [3:0]			
BYTE 3							
x	x	x	x	Current Limit [4:0]			
BYTE 4							
x	x	x	x	x	x	x	x
GLOBAL							
DATA FIELD DESCRIPTION FOR ALTERNATOR A+B SLEEP COMMAND: ID = 3C⁽²⁰⁾							
7	6	5	4	3	2	1	0
BYTE 1							
0	0	0	0	0	0	0	0
BYTE 2							
x	x	x	x	x	x	x	x
BYTE 3							
x	x	x	x	x	x	x	x
BYTE 4							
x	x	x	x	x	x	x	x

Notes

20. To access this command, NVM bit "Special LIN Features" must have been programmed

Table 10. Target/Programmed Voltage

Code	V
000000	10.6/OFF ⁽²¹⁾
000001	10.7
000010	10.8
000011	10.9
000100	11.0
000101	11.1
000110	11.2
000111	11.3
001000	11.4
001001	11.5
001010	11.6
001011	11.7
001100	11.8
001101	11.9
001110	12.0
001111	12.1
010000	12.2
010001	12.3
010010	12.4
010011	12.5
010100	12.6
010101	12.7
010110	12.8
010111	12.9
011000	13.0
011001	13.1
011010	13.2
011011	13.3
011100	13.4
011101	13.5
011110	13.6
011111	13.7

Code	V
100000	13.8 ⁽²²⁾
100001	13.9
100010	14.0
100011	14.1
100100	14.2
100101	14.3
100110	14.4
100111	14.5
101000	14.6
101001	14.7
101010	14.8
101011	14.9
101100	15.0
101101	15.1
101110	15.2
101111	15.3
110000	15.4
110001	15.5
110010	15.6
110011	15.7
110100	15.8
110101	15.9
110110	16.0
110111	16.0
111000	16.0
111001	16.0
111010	16.0
111011	16.0
111100	16.0
111101	16.0
111110	16.0
111111	16.0

Notes

21. If 000000 is sent the regulator will set 10.60 V or shutdown if no LIN command with a voltage setting higher than 10.6 V was sent beforehand.
22. Default for self-start, adjustable in OTP between 13.5 V and 15.0 V.

Table 11. LRC Programming Information.

Ramp Time	Seconds
0000	0
0001	1.3
0010	2.1
0011	3.0 ⁽²³⁾
0100	3.8
0101	4.7
0110	5.5
0111	6.4
1000	7.2
1001	8.1
1010	8.9
1011	9.8
1100	10.6
1101	11.5
1110	12.3
1111	13.2

Ramp Cut-off	RPM
0000	2400
0001	2530
0010	2670
0011	2830
0100	3000 ⁽²³⁾
0101	3200
0110	3430
0111	3690
1000	4000
1001	4360
1010	4790
1011	5320
1100	5990
1101	6860
1110	8010
1111	Always Active

Notes

23. Default, adjustable by OTP.

Table 12. Temperature Information, Sent Back to the Master.

Temperature	°C
000000	-40
000001	-36.5
000010	-33
000011	-29.5
000100	-26
000101	-22.5
000110	-19
000111	-15.5
001000	-12
001001	-8.5
001010	-5
001011	-1.5
001100	2
001101	5.5
001110	9
001111	12.5
010000	16
010001	19.5
010010	23
010011	26.5
010100	30
010101	33.5
010110	37
010111	40.5
011000	44
011001	47.5
011010	51
011011	54.5
011100	58
011101	61.5
011110	65
011111	68.5

Temperature	°C
100000	72
100001	75.5
100010	79
100011	82.5
100100	86
100101	89.5
100110	93
100111	96.5
101000	100
101001	103.5
101010	107
101011	110.5
101100	114
101101	117.5
101110	121
101111	124.5
110000	128
110001	131.5
110010	135
110011	138.5
110100	142
110101	145.5
110110	149
110111	152.5
111000	156
111001	159.5
111010	163
111011	166.5
111100	170
111101	173.5
111110	177
111111	180.5

Table 13. Excitation Information sent back to the Master.

EXC Code	EXC Current (A) ⁽²⁴⁾	DF Code (EXC duty cycle)	DF (%) ⁽²⁵⁾
000000	0	00000	0
000010	0.25	00001	3.
000100	0.5	00010	6.5
000110	0.75	00011	9.5
001000	1	00100	13
001010	1.25	00101	16
001100	1.5	00110	19.5
001110	1.75	00111	22.5
010000	2	01000	26
010010	2.25	01001	29
010100	2.5	01010	32.5
010110	2.75	01011	35.5
011000	3	01100	38.5
011010	3.25	01101	42
011100	3.5	01110	45
011110	3.75	01111	48.5
100000	4	10000	51.5
100010	4.25	10001	55
100100	4.5	10010	58
100110	4.75	10011	61.5
101000	5	10100	64.5
101010	5.25	10101	67.5
101100	5.5	10110	71
101110	5.75	10111	74
110000	6	11000	77.5
110010	6.25	11001	80.5
110100	6.5	11010	84
110110	6.75	11011	87
111000	7	11100	90.5
111010	7.25	11101	93.5
111100	7.5	11110	97
111110	7.75	11111	100

Notes

- 24. 6 bits of data will be available, but only 5 bits are tabulated.
- 25. Rounded to nearest half percent.

Table 14. More Excitation Information, Received from the Master.

Current Limitation ⁽²⁶⁾	A
00000	No Limit
00001	2.0
00010	2.0
00011	2.0
00100	2.0
00101	2.0
00110	2.0
00111	2.0
01000	2.0
01001	2.25
01010	2.5
01011	2.75
01100	3.0
01101	3.25
01110	3.5
01111	3.75
10000	4.0
10001	4.25
10010	4.5
10011	4.75
10100	5.0
10101	5.25
10110	5.5
10111	5.75
11000	6.0
11001	6.25
11010	6.5
11011	6.75
11100	7.0
11101	7.25
11110	7.5
11111	7.75

Notes

26. Default is "00000", no limitation.

THERMAL COMPENSATION

This function is activated when internal temperature is above thermal threshold (135,145,150, or 160 degrees). In this case, the V setting fixed by the LIN or by default is

compensated to reduce internal temperature. The de-rating is calculated depending on the 4 categories of V setting.

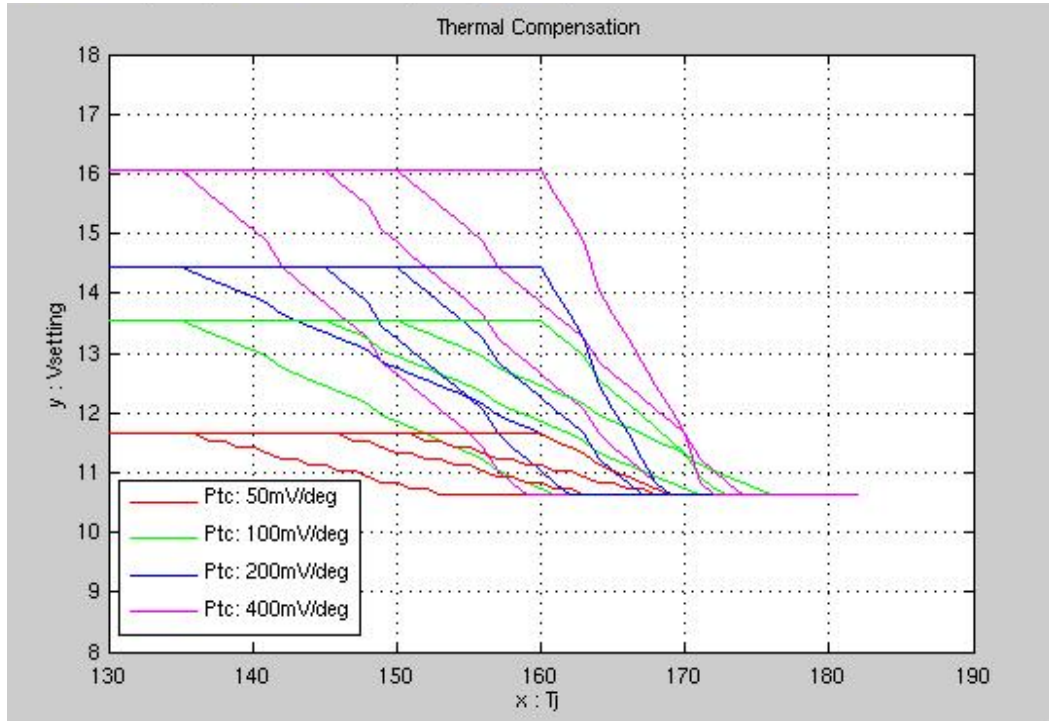

Figure 11. Thermal Compensation

Table 15. Thermal Compensation

Ptc (mV/degree)		Thermal Threshold (degrees)			
Vset[5:4]	Vset (V)	135	145	150	160
00	10.6-12.1 V	50	50	50	100
01	12.2-13.7 V	100	100	100	200
10	13.8-15.3 V	100	200	200	400
11	15.4-16 V	200	200	200	400

PROTECTION AND DIAGNOSIS FEATURES

FAULT DETECTION

General Notes

All fault reporting passes through a 400 ms digital filter to avoid false indication problems, and transition from one fault type to another should be “clean”.

MECHANICAL FAULT (F_MEC)

The Phase is off (Low Phase RPM below stop_regulation threshold). Reported in Alternator A/B read data field (ID=11, 13), byte 1.

ELECTRICAL FAULT (F_EL)

If one of these faults appear:

- The number of “1”s in all the OTP bits, NVM[80:1] is not ODD. The parity bit is included in the calculation
- The Phase is on (Low Phase RPM above stop_regulation threshold) but High Phase 1 is not detected
- B+A reaches 16.5 V with EXC at 100% DC
- Short circuit excitation load
- B+A stays at 75% of the target voltage when LRC is off

Note: This 5th additional condition is enabled only when the NVM bit “Low Voltage Threshold” is enabled. Reported in Alternator A/B read data field (ID=11, 13), byte 1.

ELECTRICAL FAULT (HP MASK)

A fault detection when High phase signal is cut is reported on the electrical fault.

Option (OTP) available to remove this fault detection.

THERMAL FAULT (F_HT)

A thermal fault is reported when the die temperature exceeds the programmed threshold. Reported in Alternator A/B read data field (ID=11, 13), byte 1.

The programmed threshold in hexadecimal corresponds to the following temperature in degrees:

- 6'b110010;//135degrees
- 6'b110100;//145degrees
- 6'b110110;//150degrees
- 6'b111001;//160degrees

ADDITIONAL ERRORS

LIN Bus Timeout

Check two timeouts:

- Activity on RXD is below 3 or 8 seconds (depending on the OTP bit)
- Time between two consecutive valid messages is below 3 or 8 seconds (depending on the OTP bit)

This flag is reset once the microcontroller sends MID 11 for ALTA, or MID 13 for Alt B. Reported in Alternator A/B read data field (ID=11, 13), byte 2.

Comm Error

Checks the ID parity bits + Checksum byte + (TXD = RXD when responding) + LIN Physical layout not in over-current limitation. Reported in Alternator A/B read data field (ID=11, 13), byte 2.

LIN protocol errors:

- Sync Break Error: This flag is up when Synchro break Field duration is lower than 10Tbits.
- Identifier parity Error: Comm error flag also reported in MID11
- Checksum Error: Comm error flag also reported in MID11
- Slave not responding Error: Tframe Max exceeded (LIN Specification revision 1.3).

These flags are reset once the microcontroller sends MID 12 for ALTA, or MID 14 for Alt B. Reported in Alternator A/B read data field (ID=12, 14), byte 2.

PACKAGING

DIE DIMENSIONS

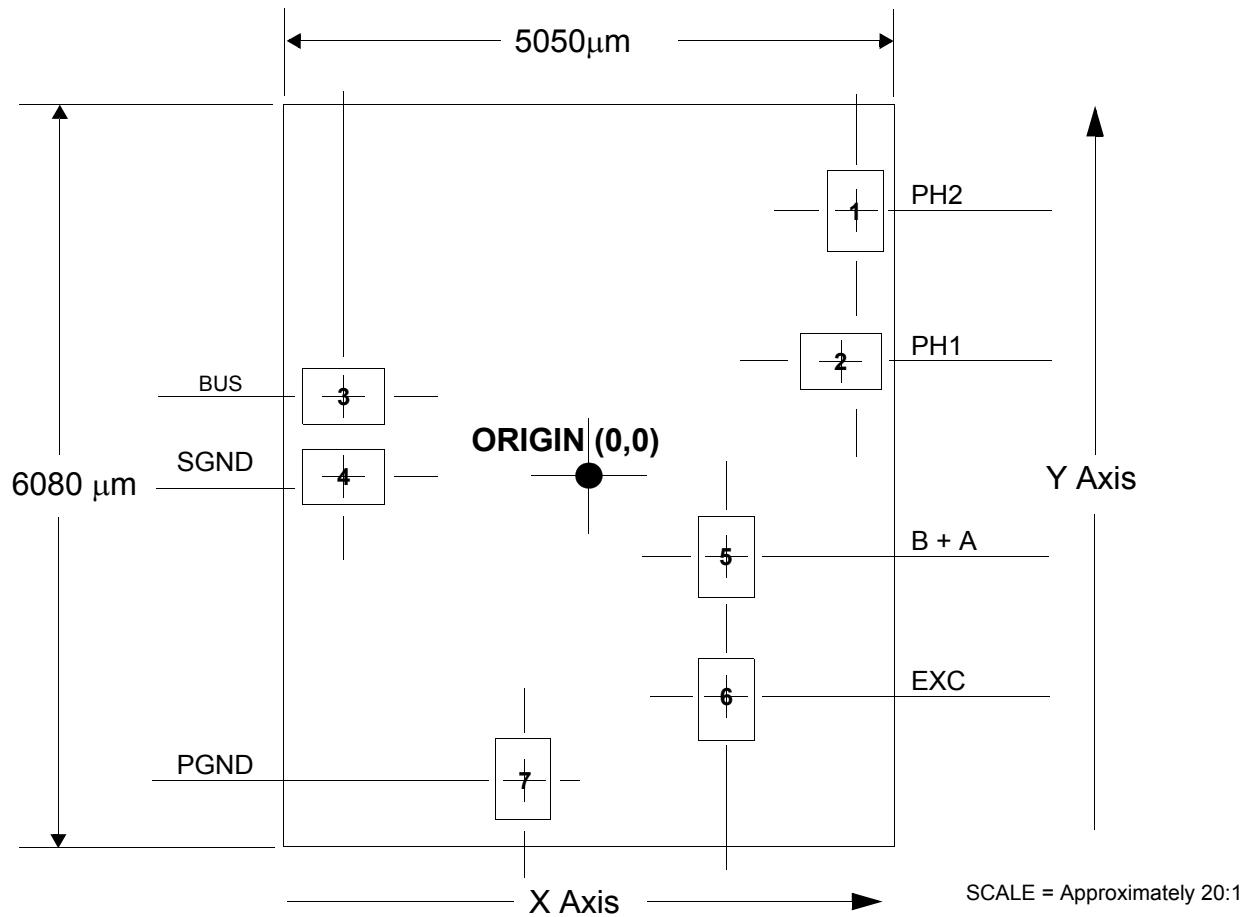

Pad	Function	Die Coordinates (Origin at Center of Die)	
		X/ μm	Y/ μm
1	PH2	2166	2158
2	PH1	2098	1217
3	BUS	-1989	834
4	SIGNAL GROUND ⁽²⁷⁾	-1989	0
5	B + A	1179	-840
6	EXC	1179	-1987
7	POWER GROUND ⁽²⁷⁾	-367	-2631

Notes

27. Both Signal and Power Grounds must be connected for correct operation.

DIE CHARACTERISTICS

The die is designed to be fitted into a customer designed package, however as so many wiring configurations exist not all may be possible from the same die design. Due to thermal considerations, soldering is the preferred die attach method, but under some circumstances, conductive epoxy may be acceptable.

Table 16. Physical Die Characteristics.

Mechanical data	Length	Width	Units
Main Bonding Pad Size (200 μ m wire)	0.66	0.5	mm
Die Size (Length x Width)	6.08	5.05	mm
Die Thickness	0.36	N/A	mm
Die Back Metal Composition	Cr/CrAg/Ag	N/A	N/A
Die Back Metal Thickness, Typical	2.1	N/A	μ m
Die Top Metal Thickness, Typical	2.0	N/A	μ m
Die Top Metal Composition	99.5 Al	0.5 Cu	%

OTP DEFAULT CONFIGURATION (WITHOUT ANY PROGRAMMING)

Default Regulation Voltage: **13.5 V**

Phase Start Regulation: **800 RPM**

Phase Stop Regulation: **500 RPM**

LRC disable: **2400 RPM**

LRC Rate: **No LRC**

Alternator Pole-pairs: **6**

Slave Address: **MID 29/11/12**

Self start: **ON**

Self start threshold: **3000 RPM**

BUS Time-out: **3 s**

LIN Readout: **Current**

Thermal Compensation Threshold: **160 °C**

10.6 V Reg: **OFF**.

The 10.6 V command is a real 10.6 V regulation when phase is ON (if Programmed, this command becomes a regulation OFF command; lower regulation command is 10.7 V)

EL Fault HP mask: **ON**

The fault detection when the high phase signal is cut, is reported on the electrical fault (if programmed, this part of the electrical fault is masked)

Low voltage threshold: **none**

One pole Filter: No, **default is 2 pole filter**

Crest regulation: **OFF**

LIN Com with Global ID (MID 2B + 3C): **OFF**

CREST REGULATION

Crest regulation bit OFF: The product is in load dump mode. EXC is stopped when the internal filter reaches Load dump detection threshold (21 V typ.). The delay is given by the internal filter (~1.0 ms).

Crest regulation bit is ON: The product is in crest regulation mode. EXC is stopped immediately when internal ADC reaches 21 V. The delay is given by the ADC (~16 µs).

For these two modes, Load Dump or Crest regulation, EXC is always OFF if the condition on B+A is present.

REVISION HISTORY

REVISION	DATE	DESCRIPTION OF CHANGES
1.0	12/2008	<ul style="list-style-type: none">• Initial Release
2.0	5/2011	<ul style="list-style-type: none">• Add ESD values and electrical characteristics• Add limits max/min in electrical characteristics table + graphs• Remove backmetal option• Add Table1 Page 2. Version-determined Electrical parameters• Change Thermal Shutdown value, Modification in the LIN fault detection paragraph.• Change wording in LIN Fault detection paragraph• Add machine Model in electrical ratings table• Change LIN timeout value (1.3s instead of 8s) + slight changes in diagrams• Wording change• Change in table 1 page 3 on BUS inactivity column from 3/8 to 1.31/3• Change in figure 1 and 2 + device table• Added TC80310AWS to the ordering information

How to Reach Us:

Home Page:

www.freescale.com

Web Support:

<http://www.freescale.com/support>

USA/Europe or Locations Not Listed:

Freescale Semiconductor, Inc.
Technical Information Center, EL516
2100 East Elliot Road
Tempe, Arizona 85284
1-800-521-6274 or +1-480-768-2130
www.freescale.com/support

Europe, Middle East, and Africa:

Freescale Halbleiter Deutschland GmbH
Technical Information Center
Schatzbogen 7
81829 Muenchen, Germany
+44 1296 380 456 (English)
+46 8 52200080 (English)
+49 89 92103 559 (German)
+33 1 69 35 48 48 (French)
www.freescale.com/support

Japan:

Freescale Semiconductor Japan Ltd.
Headquarters
ARCO Tower 15F
1-8-1, Shimo-Meguro, Meguro-ku,
Tokyo 153-0064
Japan
0120 191014 or +81 3 5437 9125
support.japan@freescale.com

Asia/Pacific:

Freescale Semiconductor China Ltd.
Exchange Building 23F
No. 118 Jianguo Road
Chaoyang District
Beijing 100022
China
+86 10 5879 8000
support.asia@freescale.com

For Literature Requests Only:

Freescale Semiconductor Literature Distribution Center
P.O. Box 5405
Denver, Colorado 80217
1-800-441-2447 or +1-303-675-2140
Fax: +1-303-675-2150
LDCForFreescaleSemiconductor@hibbertgroup.com

RoHS-compliant and/or Pb-free versions of Freescale products have the functionality and electrical characteristics of their non-RoHS-compliant and/or non-Pb-free counterparts. For further information, see <http://www.freescale.com> or contact your Freescale sales representative.

For information on Freescale's Environmental Products program, go to <http://www.freescale.com/epp>.

Information in this document is provided solely to enable system and software implementers to use Freescale Semiconductor products. There are no express or implied copyright licenses granted hereunder to design or fabricate any integrated circuits or integrated circuits based on the information in this document.

Freescale Semiconductor reserves the right to make changes without further notice to any products herein. Freescale Semiconductor makes no warranty, representation or guarantee regarding the suitability of its products for any particular purpose, nor does Freescale Semiconductor assume any liability arising out of the application or use of any product or circuit, and specifically disclaims any and all liability, including without limitation consequential or incidental damages. "Typical" parameters that may be provided in Freescale Semiconductor data sheets and/or specifications can and do vary in different applications and actual performance may vary over time. All operating parameters, including "Typicals", must be validated for each customer application by customer's technical experts. Freescale Semiconductor does not convey any license under its patent rights nor the rights of others. Freescale Semiconductor products are not designed, intended, or authorized for use as components in systems intended for surgical implant into the body, or other applications intended to support or sustain life, or for any other application in which the failure of the Freescale Semiconductor product could create a situation where personal injury or death may occur. Should Buyer purchase or use Freescale Semiconductor products for any such unintended or unauthorized application, Buyer shall indemnify and hold Freescale Semiconductor and its officers, employees, subsidiaries, affiliates, and distributors harmless against all claims, costs, damages, and expenses, and reasonable attorney fees arising out of, directly or indirectly, any claim of personal injury or death associated with such unintended or unauthorized use, even if such claim alleges that Freescale Semiconductor was negligent regarding the design or manufacture of the part.



Freescale™ and the Freescale logo are trademarks of Freescale Semiconductor, Inc. All other product or service names are the property of their respective owners.

© Freescale Semiconductor, Inc. 2009-2011. All rights reserved.