

ACGRA4001-HF Thru. ACGRA4007-HF

Reverse Voltage: 50 to 1000 Volts

Forward Current: 1.0 Amp

RoHS Device

Halogen Free

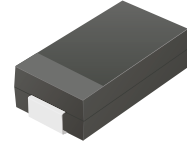

Features

- Ideal for surface mount applications.
- Low profile package.
- Built in strain relief.
- Easy pick and place.
- Plastic package has Underwriters Laboratory flammability classification 94V-0.
- Low forward drop.
- Glass passivated dip junction.
- High temperature soldering: 260°C/10 seconds at terminals
- Comply with AEC-Q101 .

Mechanical data

- Case: JEDEC DO-214AC, molded plastic.
- Terminals: Solder plated, Solderable per MIL-STD-750, Method 2026.
- Polarity: Indicated by cathode band.
- Weight: 0.064 grams(Approx.).

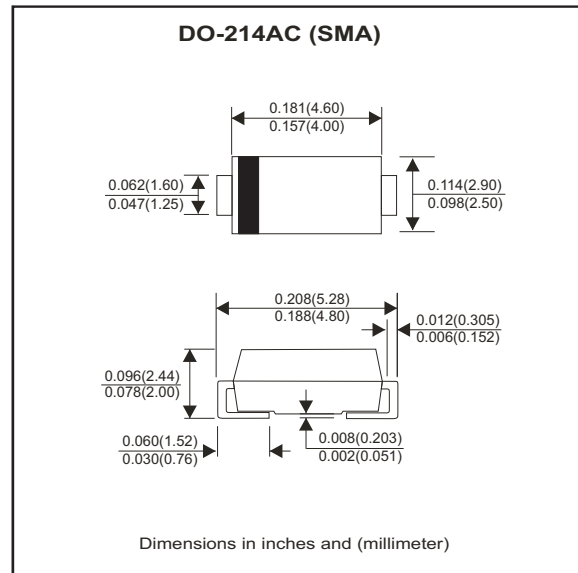

Circuit diagram



Maximum Ratings and Electrical Characteristics

Ratings at 25°C ambient temperature unless otherwise specified. Single phase half wave, 60 Hz, resistive or inductive load. For capacitive load, derate current by 20%.

Parameter	Symbol	ACGRA 4001-HF	ACGRA 4002-HF	ACGRA 4003-HF	ACGRA 4004-HF	ACGRA 4005-HF	ACGRA 4006-HF	ACGRA 4007-HF	Units
Max. Recurrent peak reverse voltage	V_{RRM}	50	100	200	400	600	800	1000	V
Max. DC blocking voltage	V_{DC}	50	100	200	400	600	800	1000	V
Max. RMS voltage	V_{RMS}	35	70	140	280	420	560	700	V
Peak forward surge current 8.3ms single half sine-wave superimposed on rate load (JEDEC method)	I_{FSM}	30							A
Max. average forward rectified current, at $T_L=75^\circ\text{C}$	$I_{(AV)}$	1.0							A
Max. instantaneous forward voltage at 1.0A	V_F	1.1							V
Max. DC reverse current at rated DC blocking voltage	$T_A=25^\circ\text{C}$	I_R							μA
	$T_A=125^\circ\text{C}$	I_R							
Max. Reverse recovery time (Note1) $T_J=25^\circ\text{C}$	T_{rr}	2.5							μs
Typical junction capacitance (Note 2)	C_J	2.5							pF
Max. Thermal resistance (Note 3)	$R_{\theta JA}$	15.0							$^\circ\text{C/W}$
Operating temperature range	T_J	-55 to +150							$^\circ\text{C}$
Storage temperature range	T_{STG}	-55 to +150							$^\circ\text{C}$

Notes: 1. Reverse recovery test condition: $I_F=0.5\text{A}$, $I_R=1.0\text{A}$, $I_{RR}=0.25\text{A}$
 2. Measured at 1MHz and applied $V_R=4.0$ volts.
 3. 8.0mm^2 (0.013mm thick) land areas.

Company reserves the right to improve product design , functions and reliability without notice.

REV:A

Rating and Characteristic Curves (ACGRA4001-HF thru. ACGRA4007-HF)

Fig.1 - Forward Current Derating Curve

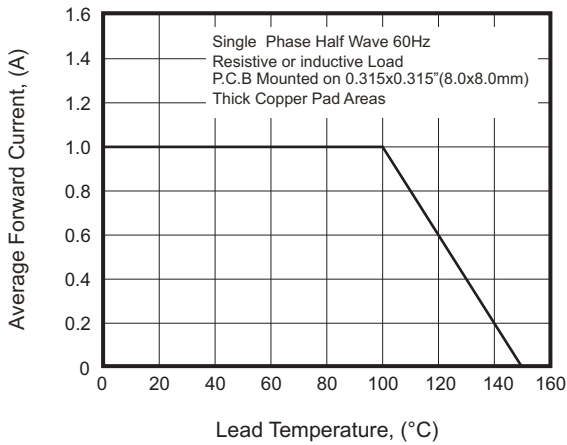

Fig.2 - Typical Instantaneous Forward Characteristics

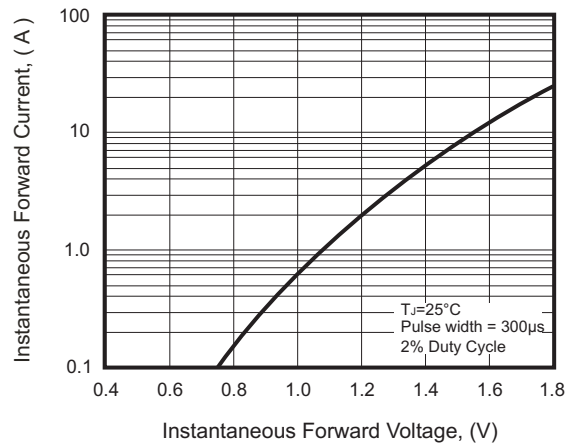

Fig.3 - Typical Reverse Characteristics

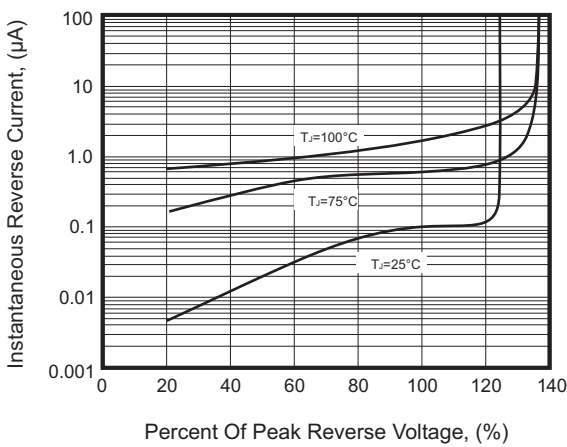

Fig.4 - Maximum Non-Repetitive peak Forward Surge Current

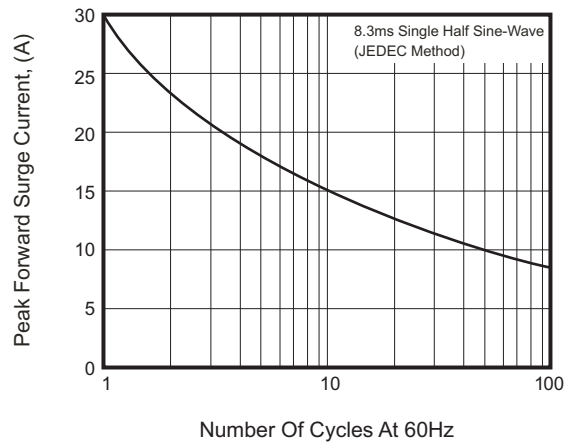

Fig.5 - Transient Thermal Impedance

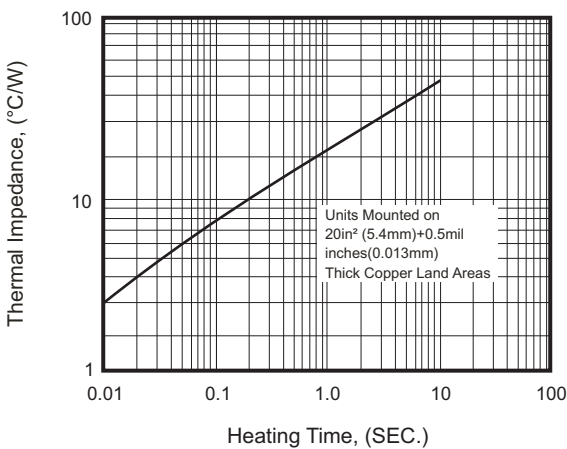
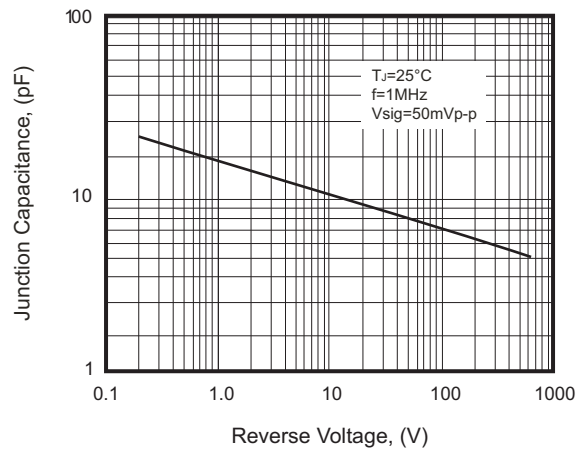
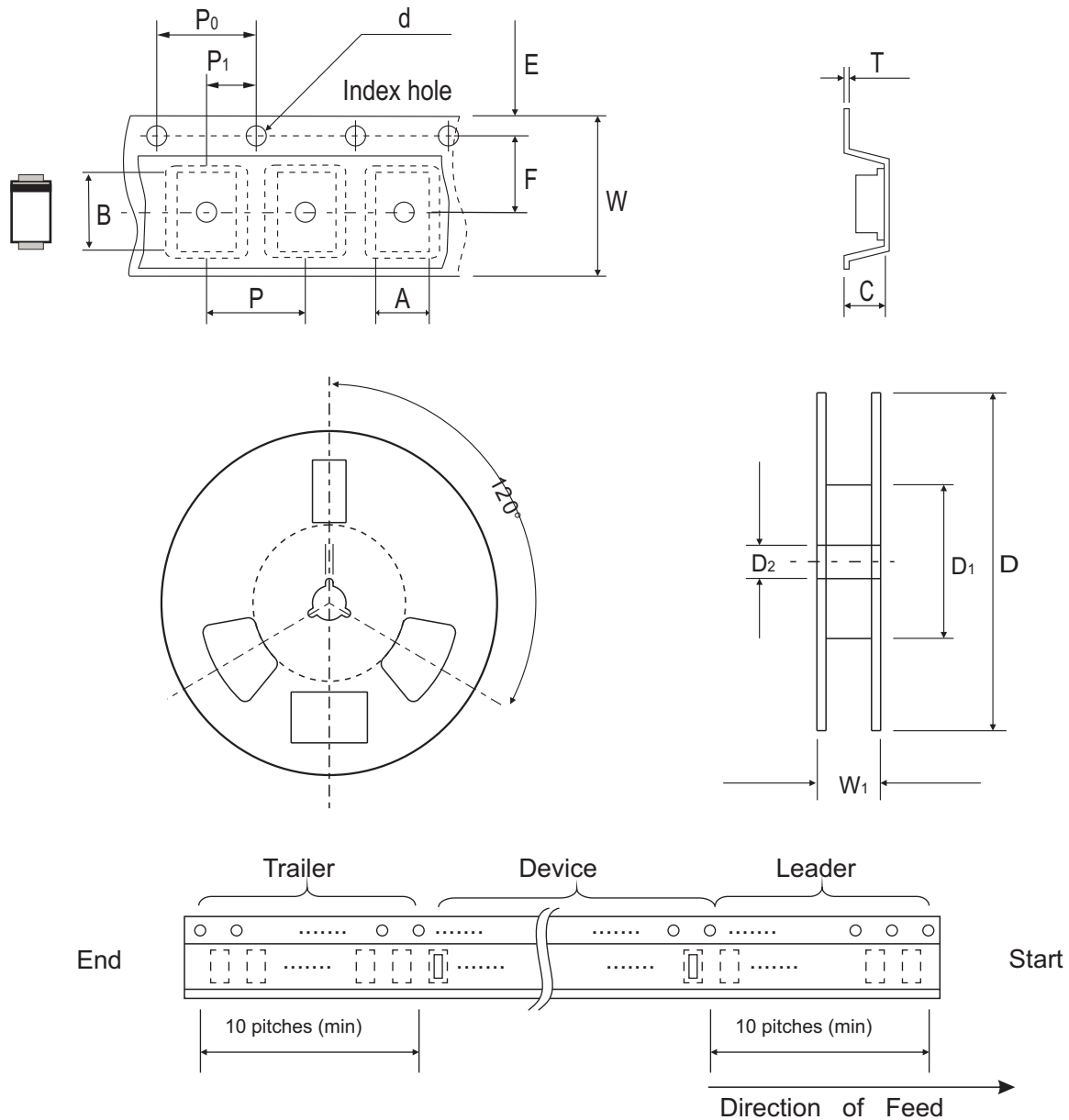

Fig.6 - Typical Junction Capacitance



Reel Taping Specification



DO-214AC (SMA)	SYMBOL	A	B	C	d	D	D1	D2
	(mm)	3.4 Max.	5.78 Max.	2.94 Max.	1.55 + 0.10	330 Max.	50.00 Min.	20.2 Max.
	(inch)	0.134 Max.	0.227 Max.	0.115 Max.	0.061 + 0.004	12.99 Max.	1.969 Min.	0.795 Max.

DO-214AC (SMA)	SYMBOL	E	F	P	P0	P1	W	W1
	(mm)	1.75 ± 0.10	5.50 ± 0.05	4.00 ± 0.10	4.00 ± 0.10	2.00 ± 0.05	12.00 ± 0.30	18.40 Max.
	(inch)	0.069 ± 0.004	0.217 ± 0.002	0.157 ± 0.004	0.157 ± 0.004	0.079 ± 0.002	0.472 ± 0.012	0.724 Max.

Marking Code

Part Number	Marking Code
ACGRA4001-HF	4001
ACGRA4002-HF	4002
ACGRA4003-HF	4003
ACGRA4004-HF	4004
ACGRA4005-HF	4005
ACGRA4006-HF	4006
ACGRA4007-HF	4007

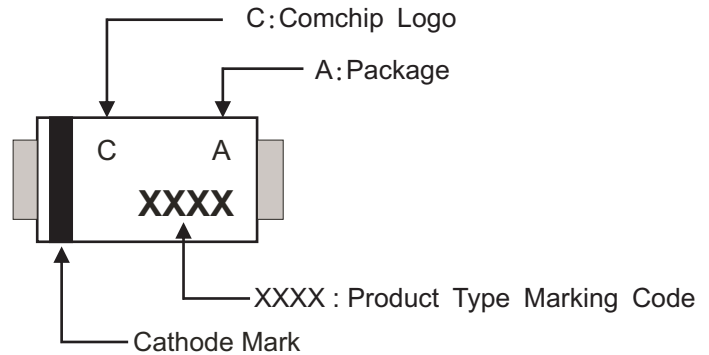

Suggested PAD Layout

SIZE	DO-214AC (SMA)	
	(mm)	(inch)
A	1.66 Max.	0.065 Max.
B	2.08 Min.	0.082 Min.
C	2.08 Min	0.082 Min.
D	5.80 REF.	0.228 REF.

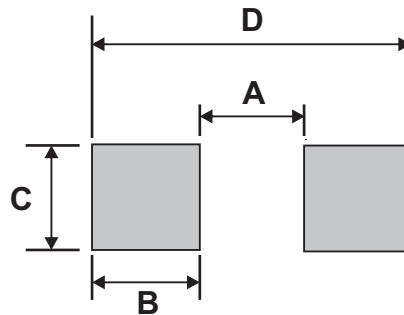

Standard Packaging

Case Type	Qty Per Reel	Reel Size
	(Pcs)	(inch)
DO-214AC (SMA)	5,000	13