

LM25183-Q1 42-V_{IN} PSR Flyback DC/DC Converter with 65-V, 2.5-A Integrated MOSFET

1 Features

- AEC-Q100-qualified for automotive applications
 - Device temperature grade 1: –40°C to 125°C ambient temperature range
- **Functional safety capable**
 - Documentation available to aid functional safety system design
- Designed for reliable and rugged applications
 - Wide input voltage range of 4.5 V to 42 V
 - Robust solution with only one component crossing the isolation barrier
 - ±1.5% total output regulation accuracy
 - Optional V_{OUT} temperature compensation
 - –40°C to +150°C junction temperature range
- Integration reduces solution size and cost
 - Integrated 65-V, 0.11-Ω power MOSFET
 - No optocoupler or transformer auxiliary winding required for V_{OUT} regulation
- High-efficiency PSR flyback operation
 - Quasi-resonant MOSFET turnoff in BCM
 - Single- and multi-output implementations
- Ultra-low conducted and radiated EMI signatures
 - Soft switching avoids diode reverse recovery
 - Optimized for **CISPR 25 Class 5** requirement
- Create a custom flyback regulator design using **WEBENCH® Power Designer**

2 Applications

- **Automotive HEV/EV powertrain systems**
- Sub-AM band **automotive body electronics**
- **Traction inverter: IGBT and SiC gate driver supplies**

Typical Application

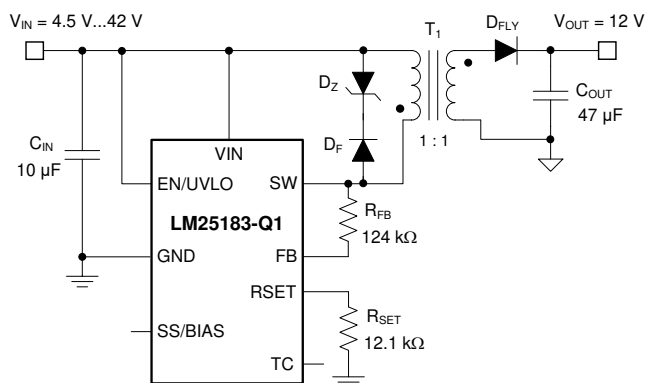

3 Description

The LM25183-Q1 is a primary-side regulated (PSR) flyback converter with high efficiency over a wide input voltage range of 4.5 V to 42 V. The isolated output voltage is sampled from the primary-side flyback voltage, eliminating the need for an optocoupler, voltage reference, or third winding from the transformer for output voltage regulation. The high level of integration results in a simple, reliable, and high-density design with only one component crossing the isolation barrier. Boundary conduction mode (BCM) switching enables a compact magnetic solution and better than ±1.5% load and line regulation performance. An integrated 65-V power MOSFET provides output power up to 10 W with enhanced headroom for line transients.

The LM25183-Q1 simplifies the implementation of isolated DC/DC supplies with optional features to optimize performance for the target end equipment. The output voltage is set by one resistor, while an optional resistor improves output voltage accuracy by negating the thermal coefficient of the flyback diode voltage drop. Additional features include an internally-fixed or externally-programmable soft-start, optional bias supply connection for higher efficiency, precision enable input with hysteresis for adjustable line UVLO, hiccup-mode overload protection, and thermal shutdown protection with automatic recovery.

The LM25183-Q1 converter is qualified to automotive AEC-Q100 grade 1 and is available in 8-pin WSON package with 0.8-mm pin pitch and wettable flanks.

Device Information⁽¹⁾

PART NUMBER	PACKAGE	BODY SIZE (NOM)
LM25183-Q1	WSON (8)	4.00 mm x 4.00 mm

(1) For all available packages, see the orderable addendum at the end of the data sheet.

Typical Efficiency, V_{OUT} = 12 V

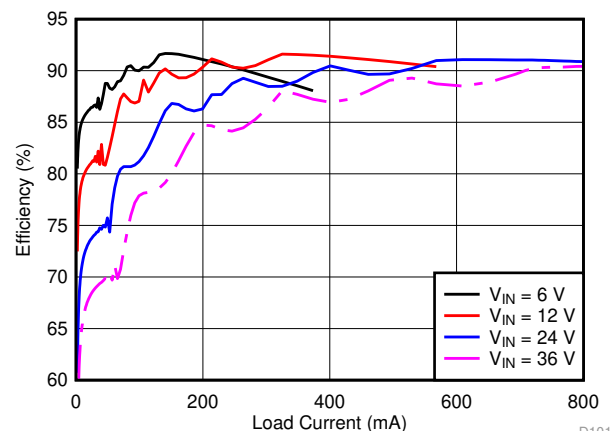

D101



Table of Contents

1 Features	1	8 Application and Implementation	16
2 Applications	1	8.1 Application Information.....	16
3 Description	1	8.2 Typical Applications	16
4 Revision History	2	9 Power Supply Recommendations	29
5 Pin Configuration and Functions	3	10 Layout	30
6 Specifications	4	10.1 Layout Guidelines	30
6.1 Absolute Maximum Ratings	4	10.2 Layout Examples.....	31
6.2 ESD Ratings.....	4	11 Device and Documentation Support	32
6.3 Recommended Operating Conditions.....	4	11.1 Device Support.....	32
6.4 Thermal Information	4	11.2 Documentation Support	33
6.5 Electrical Characteristics.....	5	11.3 Receiving Notification of Documentation Updates	33
6.6 Typical Characteristics.....	6	11.4 Support Resources	33
7 Detailed Description	9	11.5 Trademarks	34
7.1 Overview	9	11.6 Electrostatic Discharge Caution.....	34
7.2 Functional Block Diagram	9	11.7 Glossary	34
7.3 Feature Description.....	9	12 Mechanical, Packaging, and Orderable	Information
7.4 Device Functional Modes.....	15	12.1 Package Option Addendum	35

4 Revision History

NOTE: Page numbers for previous revisions may differ from page numbers in the current version.

DATE	REVISION	NOTES
April 2020	*	Initial release

5 Pin Configuration and Functions

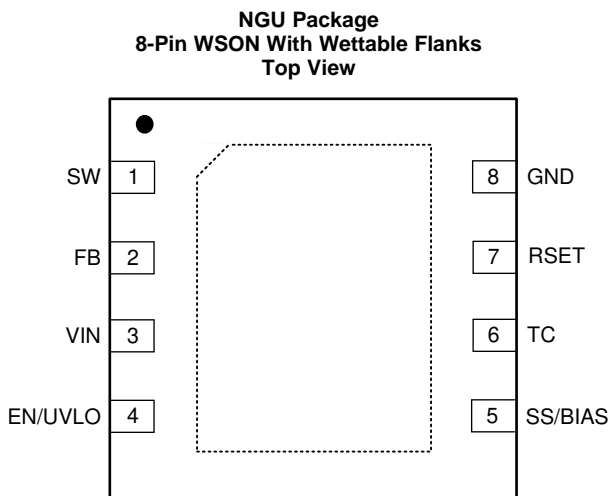

Pin Functions

PIN		I/O ⁽¹⁾	DESCRIPTION
NO.	NAME		
1	SW	P	Switch node that is internally connected to the drain of the N-channel power MOSFET. Connect to the primary-side switching terminal of the flyback transformer.
2	FB	I	Primary-side feedback pin. Connect a resistor from FB to SW. The ratio of the FB resistor to the resistor at the RSET pin sets the output voltage.
3	VIN	P/I	Input supply connection. Source for internal bias regulators and input voltage sensing pin. Connect directly to the input supply of the converter with short, low impedance paths.
4	EN/UVLO	I	Enable input and undervoltage lockout (UVLO) programming pin. If the EN/UVLO voltage is below 1.1 V, the converter is in shutdown mode with all functions disabled. If the EN/UVLO voltage is greater than 1.1 V and below 1.5 V, the converter is in standby mode with the internal regulator operational and no switching. If the EN/UVLO voltage is above 1.5 V, the start-up sequence begins.
5	SS/BIAS	I	Soft start or bias input. Connect a capacitor from SS/BIAS to GND to adjust the output start-up time and input inrush current. If SS/BIAS is left open, the internal 6-ms soft-start timer is activated. Connect an external supply to SS/BIAS to supply bias to the internal voltage regulator and enable internal soft start.
6	TC	I	Temperature compensation pin. Tie a resistor from TC to RSET to compensate for the temperature coefficient of the forward voltage drop of the secondary diode, thus improving regulation at the secondary-side output.
7	RSET	I	Reference resistor tied to GND to set the reference current for FB. Connect a 12.1-kΩ resistor from RSET to GND.
8	GND	G	Analog and power ground. Ground connection of internal control circuits and power MOSFET.

(1) P = Power, G = Ground, I = Input, O = Output

ADVANCE INFORMATION

6 Specifications

6.1 Absolute Maximum Ratings

Over the recommended operating junction temperature range of -40°C to 150°C (unless otherwise noted)⁽¹⁾

		MIN	MAX	UNIT
Input voltage	VIN to GND	-0.3	45	V
	EN/UVLO to GND	-0.3	45	
	TC to GND	-0.3	6	
	SS/BIAS to GND	-0.3	14	
	FB to GND	-0.3	45.3	
	FB to VIN	-0.3	0.3	
	RSET to GND	-0.3	3	
Output voltage	SW to GND	-1.5	70	V
	SW to GND (20-ns transient)	-3		
Operating junction temperature, T_J		-40	150	$^{\circ}\text{C}$
Storage temperature, T_{stg}		-55	150	$^{\circ}\text{C}$

(1) Stresses beyond those listed under *Absolute Maximum Ratings* may cause permanent damage to the device. These are stress ratings only, which do not imply functional operation of the device at these or any other conditions beyond those indicated under *Recommended Operating Conditions*. Exposure to absolute-maximum-rated conditions for extended periods may affect device reliability.

6.2 ESD Ratings

			VALUE	UNIT
$V_{\text{(ESD)}}$	Electrostatic discharge	Human body model (HBM), per AEC Q100-002 HBM ESD Classification Level 2 ⁽¹⁾	± 2000	V
		Charged device model (CDM), per AEC Q100-011	± 500	
		CDM ESD Classification Level C4B	± 750	

(1) AEC Q100-002 indicates HBM stressing is done in accordance with the ANSI/ESDA/JEDEC JS-001 specification.

6.3 Recommended Operating Conditions

Over the recommended operating junction temperature range of -40°C to 150°C (unless otherwise noted)

		MIN	NOM	MAX	UNIT
V_{IN}	Input voltage	4.5		42	V
V_{SW}	SW voltage			65	V
$V_{\text{EN/UVLO}}$	EN/UVLO voltage			42	V
$V_{\text{SS/BIAS}}$	SS/BIAS voltage			13	V
T_J	Operating junction temperature	-40		150	$^{\circ}\text{C}$

6.4 Thermal Information

THERMAL METRIC ⁽¹⁾		LM25183-Q1	UNIT
		NGU (WSO)	
		8 PINS	
$R_{\theta\text{JA}}$	Junction-to-ambient thermal resistance	41.3	$^{\circ}\text{C}/\text{W}$
$R_{\theta\text{JC(top)}}$	Junction-to-case (top) thermal resistance	34.7	$^{\circ}\text{C}/\text{W}$
$R_{\theta\text{JB}}$	Junction-to-board thermal resistance	19.1	$^{\circ}\text{C}/\text{W}$
Ψ_{JT}	Junction-to-top characterization parameter	0.3	$^{\circ}\text{C}/\text{W}$
Ψ_{JB}	Junction-to-board characterization parameter	19.2	$^{\circ}\text{C}/\text{W}$
$R_{\theta\text{JC(bot)}}$	Junction-to-case (bottom) thermal resistance	3.2	$^{\circ}\text{C}/\text{W}$

(1) For more information about traditional and new thermal metrics, see the [Semiconductor and IC Package Thermal Metrics](#) application report.

6.5 Electrical Characteristics

Typical values correspond to $T_J = 25^\circ\text{C}$. Minimum and maximum limits apply over the full -40°C to 150°C junction temperature range unless otherwise indicated. $V_{IN} = 12\text{ V}$ and $V_{EN/UVLO} = 2\text{ V}$ unless otherwise stated.

PARAMETER		TEST CONDITIONS	MIN	TYP	MAX	UNIT
SUPPLY CURRENT						
$I_{SHUTDOWN}$	VIN shutdown current	$V_{EN/UVLO} = 0\text{ V}$		3		μA
I_{ACTIVE}	VIN active current	$V_{EN/UVLO} = 2.5\text{ V}$, $V_{RSET} = 1.8\text{ V}$		260	375	μA
$I_{ACTIVE-BIAS}$	VIN current with BIAS connected	$V_{SS/BIAS} = 5\text{ V}$		25	50	μA
ENABLE AND INPUT UVLO						
$V_{SD-FALLING}$	Shutdown threshold	$V_{EN/UVLO}$ falling	0.3			V
$V_{SD-RISING}$	Standby threshold	$V_{EN/UVLO}$ rising		0.8	1.1	V
$V_{UV-RISING}$	Enable threshold	$V_{EN/UVLO}$ rising	1.45	1.5	1.53	V
$V_{UV-HYST}$	Enable voltage hysteresis	$V_{EN/UVLO}$ falling	0.04	0.05		V
$I_{UV-HYST}$	Enable current hysteresis	$V_{EN/UVLO} = 1.6\text{ V}$	4.2	5	5.5	μA
FEEDBACK						
I_{RSET}	RSET current	$R_{RSET} = 12.1\text{ k}\Omega$		100		μA
V_{RSET}	RSET regulation voltage	$R_{RSET} = 12.1\text{ k}\Omega$	1.191	1.21	1.224	V
$V_{FB-VIN1}$	FB to VIN voltage	$I_{FB} = 80\text{ }\mu\text{A}$	-40			mV
$V_{FB-VIN2}$	FB to VIN voltage	$I_{FB} = 120\text{ }\mu\text{A}$			40	mV
SWITCHING FREQUENCY						
F_{SW-MIN}	Minimum switching frequency			10		kHz
F_{SW-MAX}	Maximum switching frequency			350		kHz
t_{ON-MIN}	Minimum switch on-time			140		ns
DIODE THERMAL COMPENSATION						
V_{TC}	TC voltage	$I_{TC} = \pm 10\text{ }\mu\text{A}$, $T_J = 25^\circ\text{C}$		1.2	1.27	V
POWER SWITCHES						
$R_{DS(on)}$	MOSFET on-state resistance	$I_{SW} = 100\text{ mA}$		0.11		Ω
SOFT-START AND BIAS						
I_{SS}	SS ext capacitor charging current			5		μA
t_{SS}	Internal SS time			6		ms
$V_{BIAS-UVLO-RISE}$	BIAS enable voltage	$V_{SS/BIAS}$ rising		4.25	4.45	V
$V_{BIAS-UVLO-HYST}$	BIAS UVLO hysteresis	$V_{SS/BIAS}$ falling		150		mV
CURRENT LIMIT						
$I_{SW-PEAK}$	Peak current limit threshold		2.25	2.5	2.77	A
THERMAL SHUTDOWN						
T_{SD}	Thermal shutdown threshold	T_J rising		175		$^\circ\text{C}$
T_{SD-HYS}	Thermal shutdown hysteresis			10		$^\circ\text{C}$

6.6 Typical Characteristics

$V_{IN} = 24\text{ V}$, $V_{EN/UVLO} = 2\text{ V}$ (unless otherwise stated).

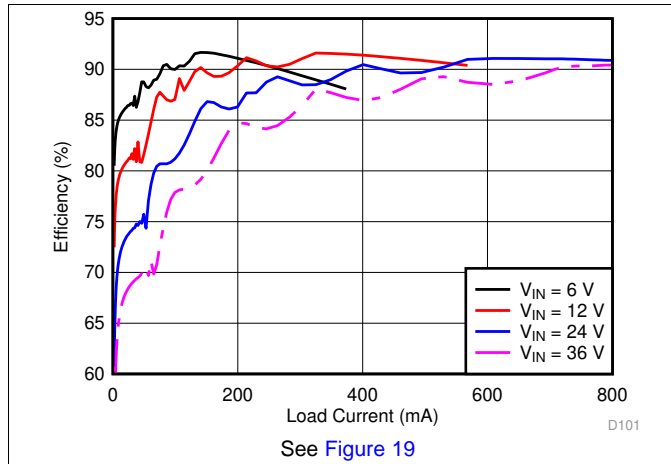

Figure 1. Efficiency versus Load

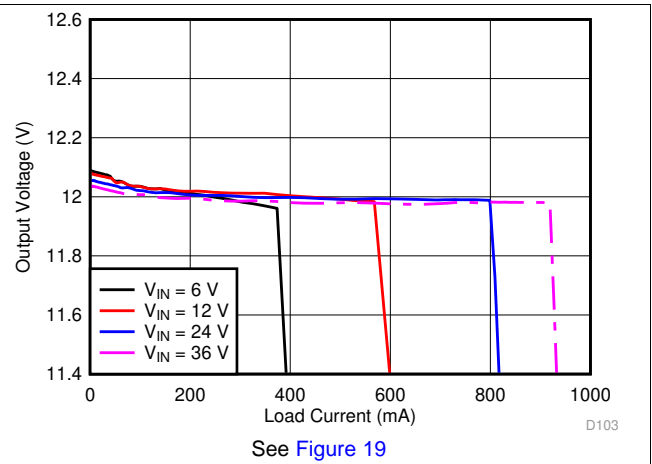

Figure 2. Output Voltage versus Load

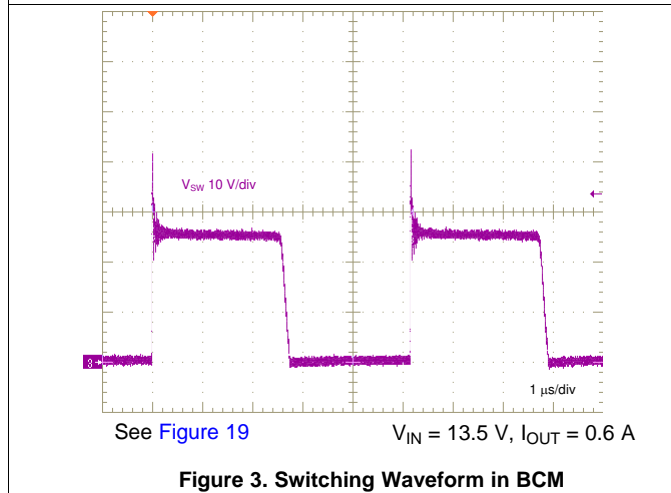

Figure 3. Switching Waveform in BCM

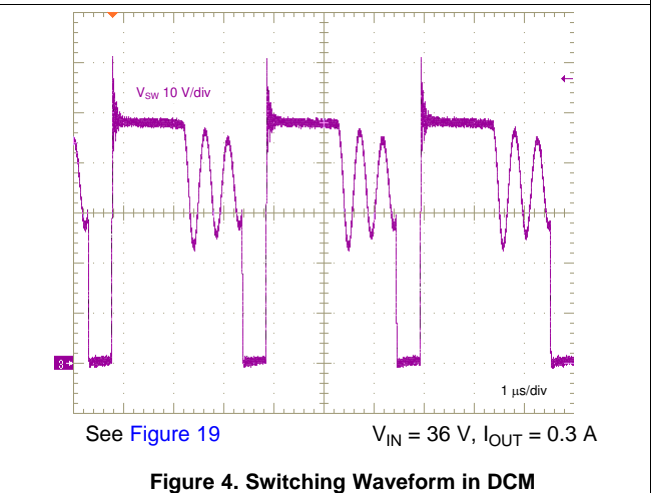

Figure 4. Switching Waveform in DCM

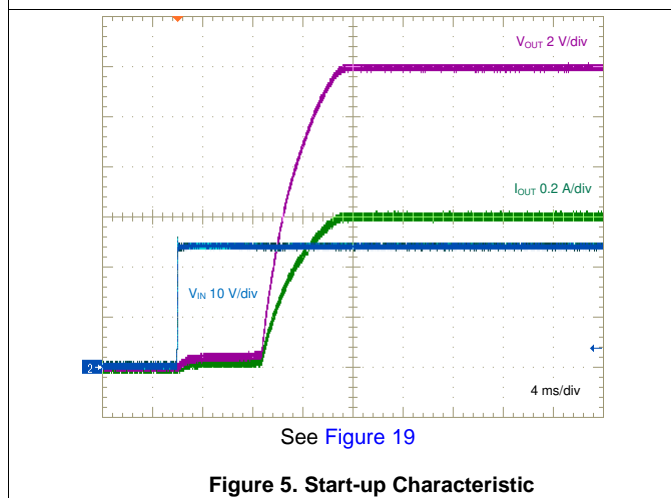

Figure 5. Start-up Characteristic

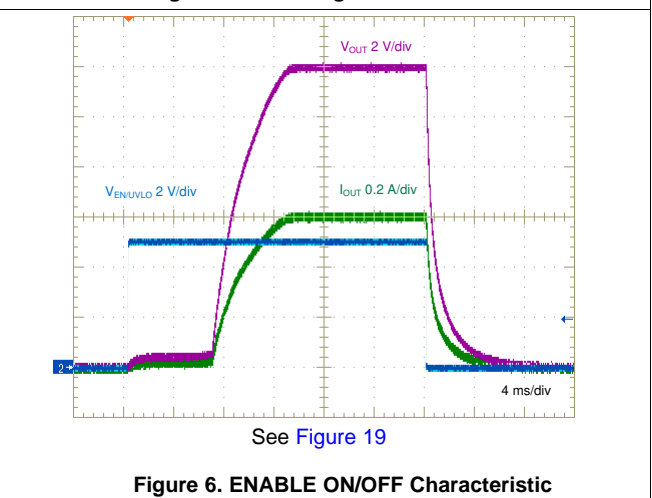

Figure 6. ENABLE ON/OFF Characteristic

Typical Characteristics (continued)

$V_{IN} = 24\text{ V}$, $V_{EN/UVLO} = 2\text{ V}$ (unless otherwise stated).

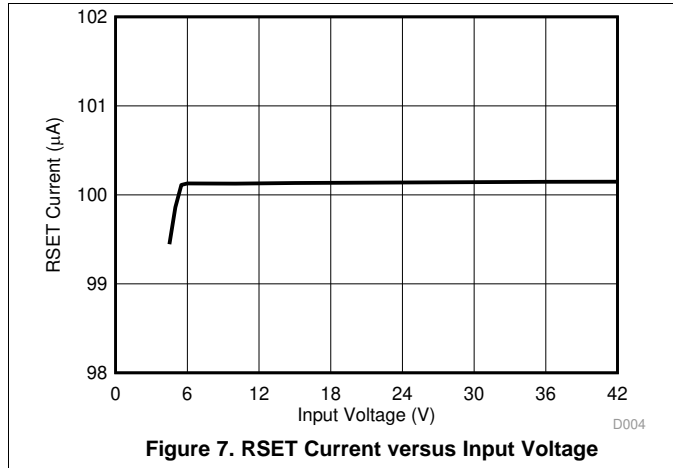

Figure 7. RSET Current versus Input Voltage

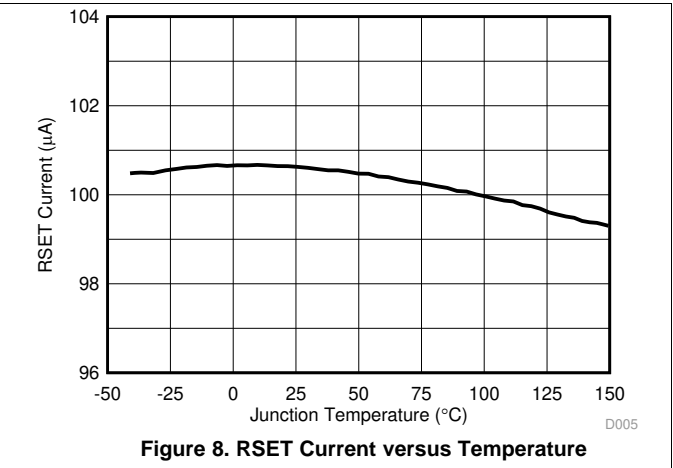

Figure 8. RSET Current versus Temperature

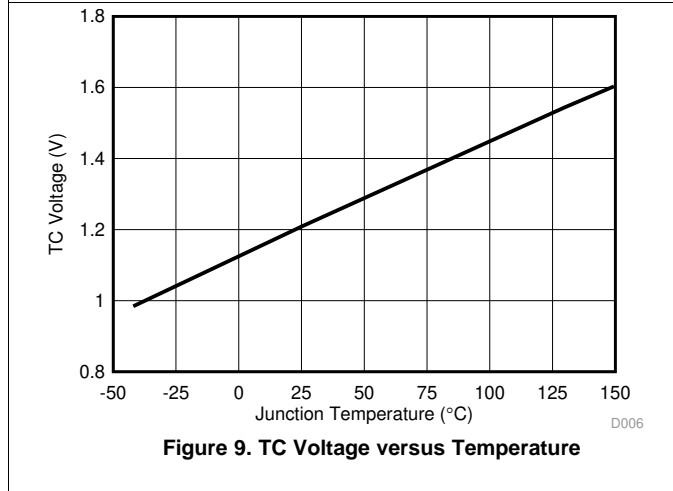

Figure 9. TC Voltage versus Temperature

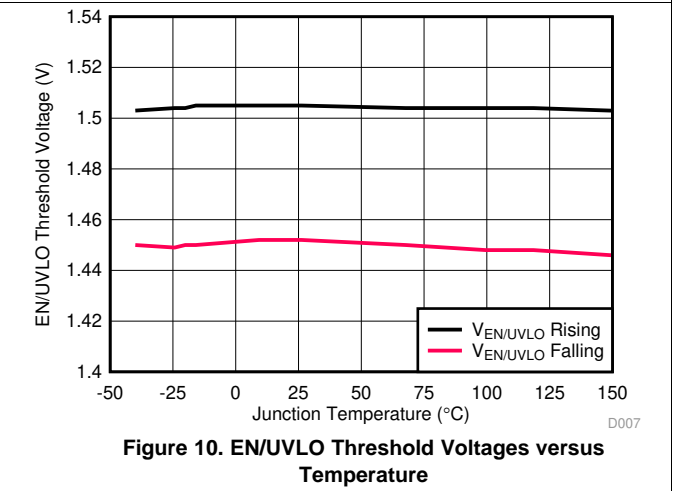

Figure 10. EN/UVLO Threshold Voltages versus Temperature

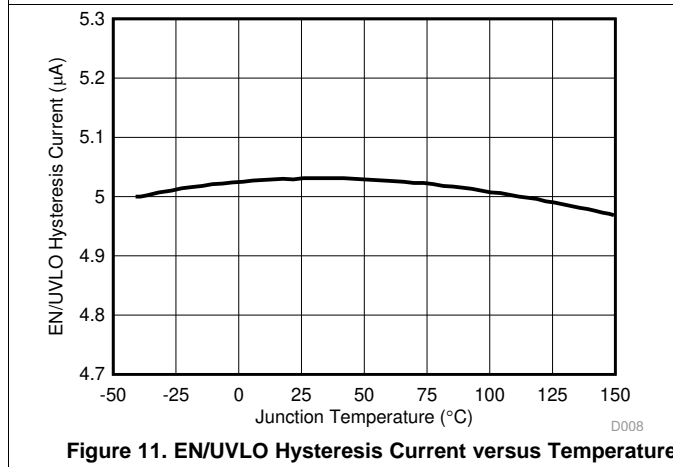

Figure 11. EN/UVLO Hysteresis Current versus Temperature

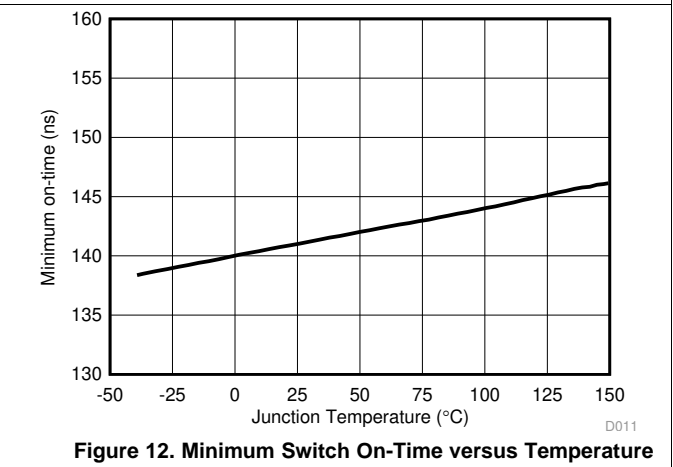
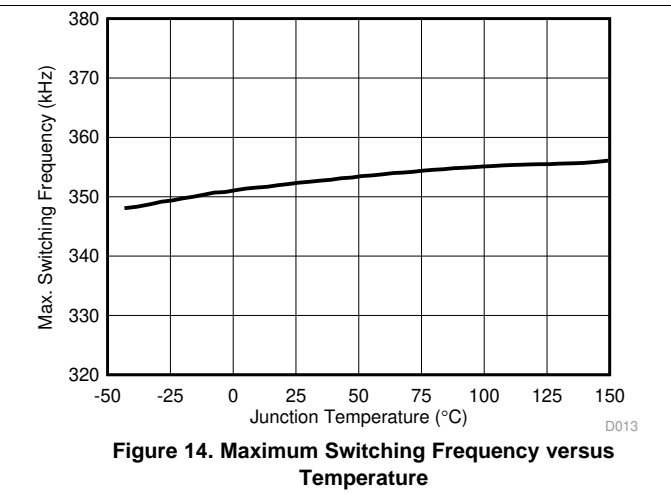
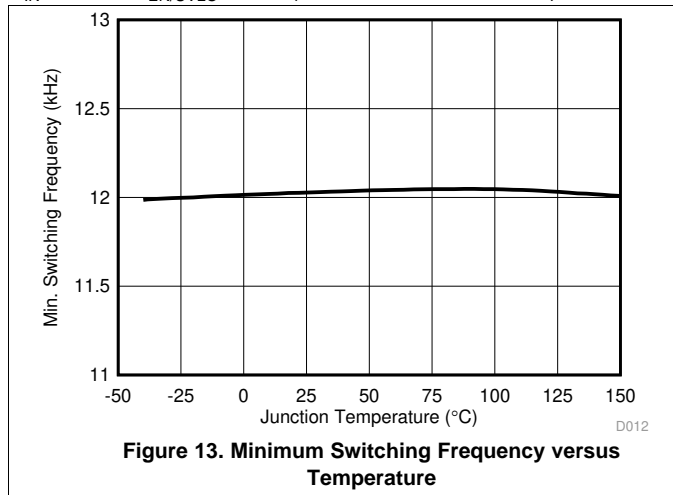

Figure 12. Minimum Switch On-Time versus Temperature

ADVANCE INFORMATION

Typical Characteristics (continued)

$V_{IN} = 24\text{ V}$, $V_{EN/UVLO} = 2\text{ V}$ (unless otherwise stated).



ADVANCE INFORMATION

7 Detailed Description

7.1 Overview

The LM25183-Q1 primary-side regulated (PSR) flyback converter is a high-density, cost-effective solution for automotive and industrial systems requiring less than 15 W of isolated DC/DC power. This compact, easy-to-use flyback converter with low I_Q can be applied over a wide input voltage range from 4.5 V to 42 V, with operation down to 3.5 V after start-up. Innovative frequency and current amplitude modulation enables high conversion efficiency across the entire load and line range. Primary-side regulation of the isolated output voltage using sampled values of the primary winding voltage eliminates the need for an opto-coupler or an auxiliary transformer winding for feedback. Regulation performance that rivals that of traditional opto-coupler solutions is achieved without the associated cost, solution size, and reliability concerns. The LM25183-Q1 converter services a wide range of applications including automotive on-board chargers and IGBT-based motor drives for HEV/EV systems.

7.2 Functional Block Diagram

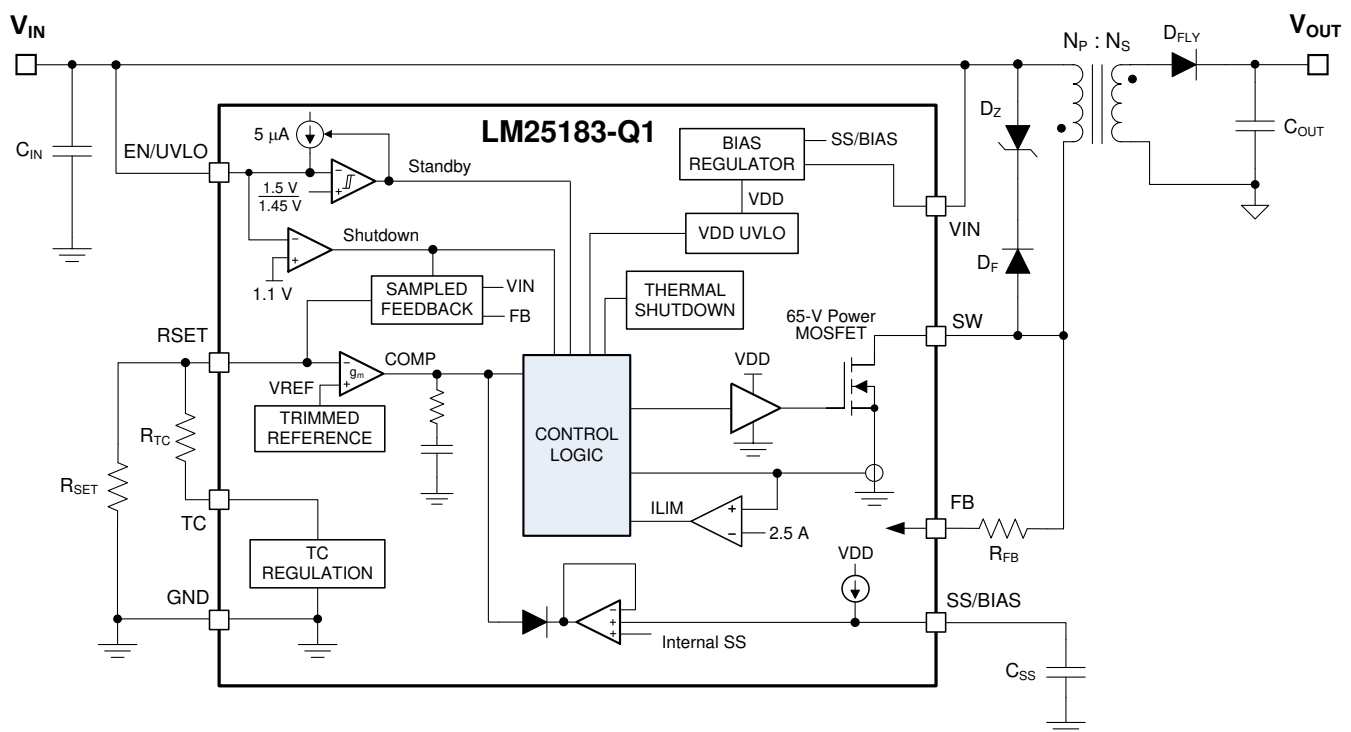

ADVANCE INFORMATION

7.3 Feature Description

7.3.1 Integrated Power MOSFET

The LM25183-Q1 is a flyback dc/dc converter with integrated 65-V, 4.1-A N-channel power MOSFET. During the MOSFET on-time, the transformer primary current increases from zero with a slope of V_{IN} / L_{MAG} (where L_{MAG} is the transformer primary-referred magnetizing inductance) while the output capacitor supplies the load current. When the high-side MOSFET is turned off by the control logic, the switch (SW) voltage V_{SW} swings up to approximately $V_{IN} + (N_{PS} \times V_{OUT})$, where $N_{PS} = N_P/N_S$ is the primary-to-secondary turns ratio of the transformer. The magnetizing current flows in the secondary side through the flyback diode, charging the output capacitor and supplying current to the load. Duty cycle D is defined as t_{ON} / t_{SW} , where t_{ON} is the MOSFET conduction time and t_{SW} is the switching period.

Figure 15 shows a typical schematic of the LM25183-Q1 PSR flyback circuit. Components denoted in red are optional depending on the application requirements.

Feature Description (continued)

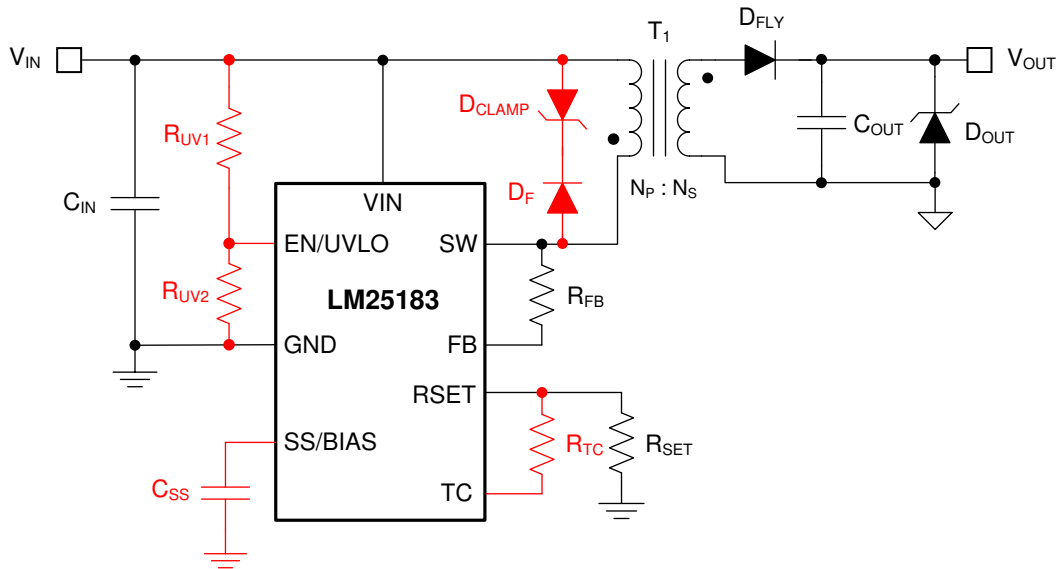

Figure 15. LM25183-Q1 Flyback Converter Schematic (Optional Components in Red)

7.3.2 PSR Flyback Modes of Operation

The LM25183-Q1 uses a variable-frequency, peak current-mode (VFPCM) control architecture with three possible modes of operation as illustrated in Figure 16.

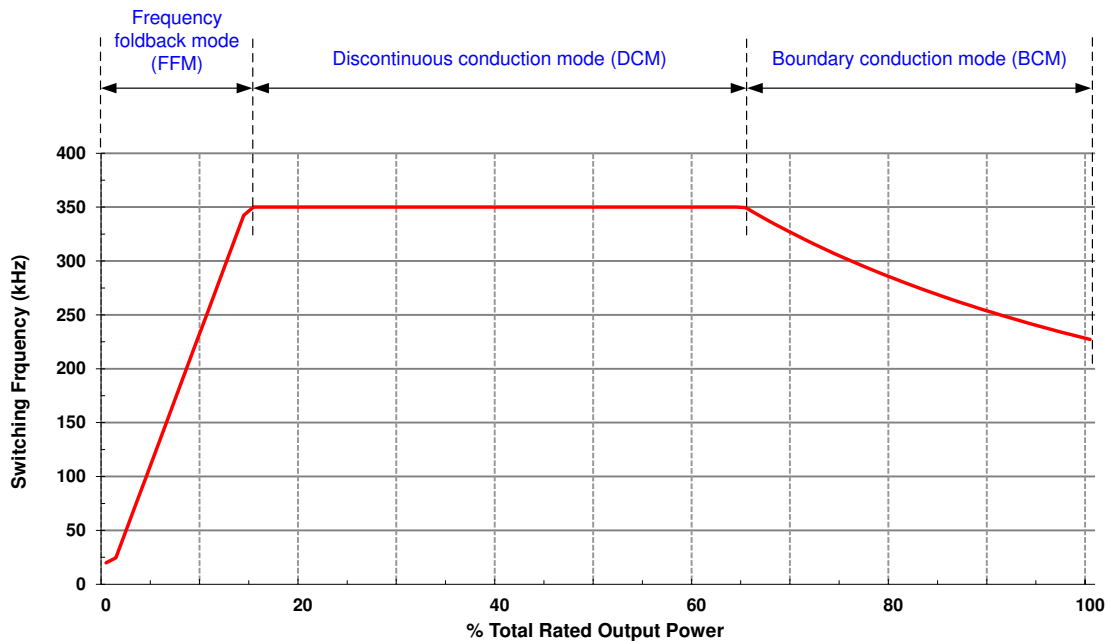

Figure 16. Three Modes of Operation Illustrated by Variation of Switching Frequency With Load

The LM25183-Q1 operates in boundary conduction mode (BCM) at heavy loads. The power MOSFET turns on when the current in the secondary winding reaches zero, and the MOSFET turns off when the peak primary current reaches the level dictated by the output of the internal error amplifier. As the load is decreased, the frequency increases to maintain BCM operation. Equation 1 gives the duty cycle of the flyback converter in BCM.

Feature Description (continued)

$$D = \frac{(V_{OUT} + V_D) \cdot N_{PS}}{V_{IN} + (V_{OUT} + V_D) \cdot N_{PS}}$$

where

- V_D is the forward voltage drop of the flyback diode as its current approaches zero (1)

Equation 2 gives the output power in BCM, where the applicable switching frequency and peak primary current are specified by Equation 3 and Equation 4, respectively.

$$P_{OUT(BCM)} = \frac{L_{MAG} \cdot I_{PRI-PK(BCM)}^2}{2} \cdot F_{SW(BCM)} \quad (2)$$

$$F_{SW(BCM)} = \frac{1}{I_{PRI-PK(BCM)} \cdot \left(\frac{L_{MAG}}{V_{IN}} + \frac{L_{MAG}}{N_{PS} \cdot (V_{OUT} + V_D)} \right)} \quad (3)$$

$$I_{PRI-PK(BCM)} = \frac{2 \cdot (V_{OUT} + V_D) \cdot I_{OUT}}{V_{IN} \cdot D} \quad (4)$$

As the load decreases, the LM25183-Q1 clamps the maximum switching frequency to 350 kHz, and the converter enters discontinuous conduction mode (DCM). The power delivered to the output in DCM is proportional to the peak primary current squared as given by Equation 5 and Equation 6. Thus, as the load decreases, the peak current reduces to maintain regulation at 350-kHz switching frequency.

$$P_{OUT(DCM)} = \frac{L_{MAG} \cdot I_{PRI-PK(DCM)}^2}{2} \cdot F_{SW(DCM)} \quad (5)$$

$$I_{PRI-PK(DCM)} = \sqrt{\frac{2 \cdot I_{OUT} \cdot (V_{OUT} + V_D)}{L_{MAG} \cdot F_{SW(DCM)}}} \quad (6)$$

$$D_{DCM} = \frac{L_{MAG} \cdot I_{PRI-PK(DCM)} \cdot F_{SW(DCM)}}{V_{IN}} \quad (7)$$

At even lighter loads, the primary-side peak current set by the internal error amplifier decreases to a minimum level of 0.82 A, or 20% of its 4.1-A peak value, and the MOSFET off-time extends to maintain the output load requirement. The system operates in frequency foldback mode (FFM), and the switching frequency decreases as the load current is reduced. Other than a fault condition, the lowest frequency of operation of the LM25183-Q1 is 12 kHz, which sets a minimum load requirement of approximately 0.5% full load.

7.3.3 Setting the Output Voltage

To minimize output voltage regulation error, the LM25183-Q1 senses the reflected secondary voltage when the secondary current reaches zero. The feedback (FB) resistor, which is connected between SW and FB is determined using Equation 8, where R_{SET} is nominally 12.1 kΩ.

$$R_{FB} = (V_{OUT} + V_D) \cdot N_{PS} \cdot \frac{R_{SET}}{V_{REF}} \quad (8)$$

7.3.3.1 Diode Thermal Compensation

The LM25183-Q1 employs a unique thermal compensation circuit that adjusts the feedback setpoint based on the thermal coefficient of the forward voltage drop of the flyback diode. Even though the output voltage is measured when the secondary current is effectively zero, there is still a non-zero forward voltage drop associated with the flyback diode. Select the thermal compensation resistor using Equation 9.

Feature Description (continued)

$$R_{TC} [k\Omega] = \frac{R_{FB} [k\Omega]}{N_{PS}} \cdot \frac{3}{TC_{Diode} [mV/^{\circ}C]} \quad (9)$$

The temperature coefficient of the diode voltage drop may not be explicitly provided in the diode data sheet, so the effective value can be estimated based on the measured output voltage shift over temperature when the TC resistor is not installed.

7.3.4 Control Loop Error Amplifier

The inputs of the error amplifier include a level-shifted version of the FB voltage and an internal 1.21-V reference set by the resistor at RSET. A type-2 internal compensation network stabilizes the converter. In BCM operation when the output voltage is in regulation, an on-time interval is initiated when the secondary current reaches zero. The power MOSFET is subsequently turned off when an amplified version of the peak primary current exceeds the error amplifier output.

7.3.5 Precision Enable

The precision EN/UVLO input supports adjustable input undervoltage lockout (UVLO) with hysteresis for application specific power-up and power-down requirements. EN/UVLO connects to a comparator with a 1.5-V reference voltage and 50-mV hysteresis. An external logic signal can be used to drive the EN/UVLO input to toggle the output on and off for system sequencing or protection. The simplest way to enable the LM25183-Q1 is to connect EN/UVLO directly to V_{IN} . This allows the LM25183-Q1 to start up when V_{IN} is within its valid operating range. However, many applications benefit from using resistor divider R_{UV1} and R_{UV2} as shown in Figure 17 to establish a precision UVLO level.

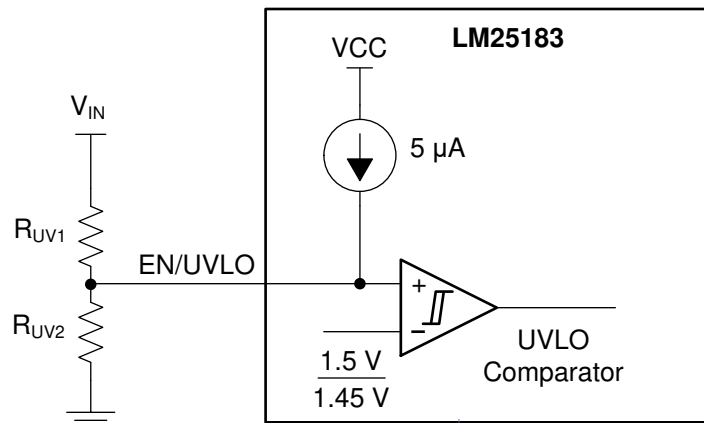

Figure 17. Programmable Input Voltage UVLO With Hysteresis

Use Equation 10 and Equation 11 to calculate the input UVLO voltages turnon and turnoff voltages, respectively.

$$V_{IN(on)} = V_{UV-RISING} \left(1 + \frac{R_{UV1}}{R_{UV2}} \right)$$

where

- $V_{UV-RISING}$ and $V_{UV-FALLING}$ are the UVLO comparator thresholds
- $I_{UV-HYST}$ is the hysteresis current

$$V_{IN(off)} = V_{UV-FALLING} \left(1 + \frac{R_{UV1}}{R_{UV2}} \right) - I_{UV-HYST} \cdot R_{UV1} \quad (11)$$

Feature Description (continued)

The LM25183-Q1 also provides a low- I_Q shutdown mode when the EN/UVLO voltage is pulled below a base-emitter voltage drop (approximately 0.6 V at room temperature). If the EN/UVLO voltage is below this hard shutdown threshold, the internal LDO regulator powers off, and the internal bias-supply rail collapses, shutting down the bias currents of the LM25183-Q1. The LM25183-Q1 operates in standby mode when the EN/UVLO voltage is between the hard shutdown and precision-enable thresholds.

7.3.6 Configurable Soft Start

The LM25183-Q1 has a flexible and easy-to-use soft-start control pin, SS/BIAS. The soft-start feature prevents inrush current impacting the LM25183-Q1 and the input supply when power is first applied. This is achieved by controlling the voltage at the output of the internal error amplifier. Soft start is achieved by slowly ramping up the target regulation voltage when the device is first enabled or powered up. Selectable and adjustable start-up timing options include a 6-ms internally-fixed soft start and an externally-programmable soft start.

The simplest way to use the LM25183-Q1 is to leave SS/BIAS open. The LM25183-Q1 employs an internal soft-start control ramp and starts up to the regulated output voltage in 6 ms.

However, in applications with a large amount of output capacitance, higher V_{OUT} , or other special requirements, the soft-start time can be extended by connecting an external capacitor C_{SS} from SS/BIAS to GND. A longer soft-start time further reduces the supply current needed to charge the output capacitors while sourcing the required load current. When the EN/UVLO voltage exceeds the UVLO rising threshold and a delay of 20 μ s expires, an internal current source I_{SS} of 5 μ A charges C_{SS} and generates a ramp to control the primary current amplitude. Calculate the soft-start capacitance for a desired soft-start time, t_{SS} , using Equation 12.

$$C_{SS} [\text{nF}] = 5 \cdot t_{SS} [\text{ms}] \tag{12}$$

C_{SS} is discharged by an internal FET when switching is disabled by EN/UVLO or thermal shutdown.

7.3.7 External Bias Supply

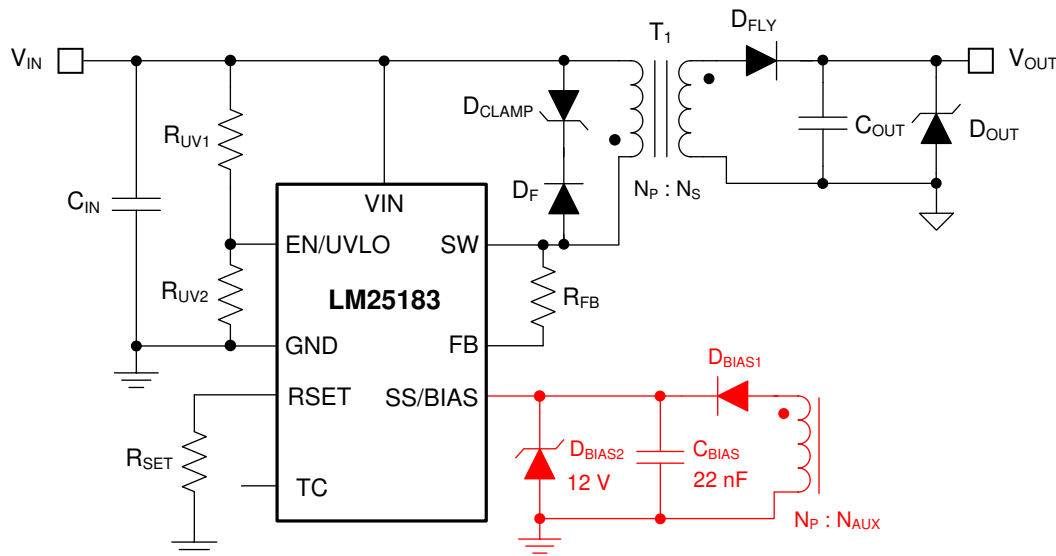

Figure 18. External Bias Supply Using Transformer Auxiliary Winding

The LM25183-Q1 has an external bias supply feature that reduces input quiescent current and increases efficiency. When the voltage at SS/BIAS exceeds a rising threshold of 4.25 V, bias power for the internal LDO regulator can be derived from an external voltage source or from a transformer auxiliary winding as shown in Figure 18. With a bias supply connected, the LM25183-Q1 then uses its internal soft-start ramp to control the primary current during start-up.

Feature Description (continued)

When using a transformer auxiliary winding for bias power, the total leakage current related to diodes D_{BIAS1} and D_{BIAS2} in [Figure 18](#) must be less than 1 μA across the full operating temperature range.

7.3.8 Minimum On-Time and Off-Time

When the internal power MOSFET is turned off, the leakage inductance of the transformer resonates with the SW node parasitic capacitance. The resultant ringing behavior can be excessive with large transformer leakage inductance and can corrupt the secondary zero-current detection. To prevent such a situation, a minimum switch off-time, designated as $t_{OFF-MIN}$, of a maximum of 375 ns is set internally to ensure proper functionality. This sets a lower limit for the transformer magnetizing inductance as discussed in the [Detailed Design Procedure](#).

Furthermore, noise effects as a result of power MOSFET turnon can impact the internal current sense circuit measurement. To mitigate this effect, the LM25183-Q1 provides a blanking time after the MOSFET turns on. This blanking time forces a minimum on-time, t_{ON-MIN} , of 140 ns.

7.3.9 Overcurrent Protection

In case of an overcurrent condition on the isolated output or outputs, the output voltage drops lower than the regulation level since the maximum power delivered is limited by the peak current capability on the primary side. The peak primary current is maintained at 4.1 A (plus an amount related to the 100-ns propagation delay of the current limit comparator) until the output decreases to the secondary diode voltage drop to impact the reflected signal on the primary side. At this point, the LM25183-Q1 assumes the output cannot be recovered and recalibrates its switching frequency to 9 kHz until the overload condition is removed. The LM25183-Q1 responds with similar behavior to an output short circuit condition.

For a given input voltage, [Equation 13](#) gives the maximum output current prior to the engagement of overcurrent protection. The typical threshold value for $I_{SW-PEAK}$ from the [Electrical Characteristics](#) is 2.5 A.

$$I_{OUT(max)} = \frac{I_{SW-PEAK}}{2 \cdot \left[\frac{V_{OUT} + V_D}{V_{IN}} + \frac{1}{N_{PS}} \right]} \quad (13)$$

7.3.10 Thermal Shutdown

Thermal shutdown is an integrated self-protection to limit junction temperature and prevent damage related to overheating. Thermal shutdown turns off the device when the junction temperature exceeds 175°C to prevent further power dissipation and temperature rise. Junction temperature decreases after shutdown, and the LM25183-Q1 restarts when the junction temperature falls to 165°C.

7.4 Device Functional Modes

7.4.1 Shutdown Mode

EN/UVLO facilitates ON and OFF control for the LM25183-Q1. When $V_{EN/UVLO}$ is below approximately 0.6 V, the device is in shutdown mode. Both the internal LDO and the switching regulator are off. The quiescent current in shutdown mode drops to 3 μ A at $V_{IN} = 24$ V. The LM25183-Q1 also employs internal bias rail undervoltage protection. If the internal bias supply voltage is below its UV threshold, the converter remains off.

7.4.2 Standby Mode

The internal bias rail LDO regulator has a lower enable threshold than the converter itself. When $V_{EN/UVLO}$ is above 0.6 V and below the precision-enable threshold (1.5 V typically), the internal LDO is on and regulating. The precision enable circuitry is turned on once the internal VCC is above its UV threshold. The switching action and voltage regulation are not enabled until $V_{EN/UVLO}$ rises above the precision enable threshold.

7.4.3 Active Mode

The LM25183-Q1 is in active mode when $V_{EN/UVLO}$ is above the precision-enable threshold and the internal bias rail is above its UV threshold. The LM25183-Q1 operates in one of three modes depending on the load current requirement:

1. Boundary conduction mode (BCM) at heavy loads
2. Discontinuous conduction mode (DCM) at medium loads
3. Frequency foldback mode (FFM) at light loads

Refer to the [PSR Flyback Modes of Operation](#) section for more detail.

8 Application and Implementation

NOTE

Information in the following applications sections is not part of the TI component specification, and TI does not warrant its accuracy or completeness. TI's customers are responsible for determining suitability of components for their purposes. Customers should validate and test their design implementation to confirm system functionality.

8.1 Application Information

The LM25183-Q1 requires only a few external components to convert from a wide range of supply voltages to one or more isolated output rails. To expedite and streamline the process of designing of a LM25183-Q1-based converter, a comprehensive LM25183-Q1 [quick-start calculator](#) is available for download to assist the designer with component selection for a given application. [WEBENCH®](#) online software is also available to generate complete designs, leveraging iterative design procedures and access to comprehensive component databases. The following sections discuss the design procedure for both single- and dual-output implementations using specific circuit design examples.

As mentioned previously, the LM25183-Q1 also integrates several optional features to meet system design requirements, including precision enable, input UVLO, programmable soft start, output voltage thermal compensation, and external bias supply connection. Each application incorporates these features as needed for a more comprehensive design.

The application circuits detailed in the [Typical Applications](#) show LM25183-Q1 configuration options suitable for several application use cases. Refer to the [LM25184EVM-S12 EVM](#) user's guide for more detail.

8.2 Typical Applications

For step-by-step design procedures, circuit schematics, bill of materials, PCB files, simulation and test results of LM25183-Q1-powered implementations, refer to the [TI Reference Design](#) library.

8.2.1 Design 1: Wide V_{IN} , Low I_Q PSR Flyback Converter Rated at 12 V, 0.6 A

The schematic diagram of a 12-V, 0.6-A PSR flyback converter is given in [Figure 19](#).

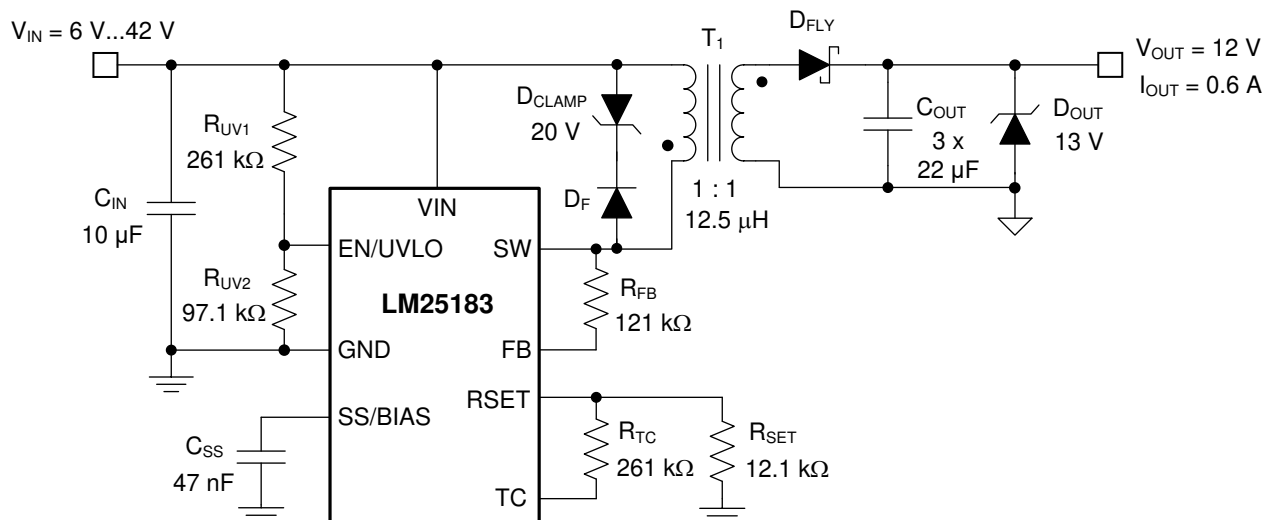

Figure 19. Schematic for Design 1 With $V_{IN(nom)} = 24 V$, $V_{OUT} = 12 V$, $I_{OUT} = 0.6 A$

8.2.1.1 Design Requirements

The required input, output, and performance parameters for this application example are shown in [Table 1](#).

Table 1. Design Parameters

DESIGN PARAMETER	VALUE
Input voltage range	6 V to 36 V
Input UVLO thresholds	5.5 V on, 4 V off
Output voltage	12 V
Rated load current, $V_{IN} \geq 13.5$ V	0.6 A
Output voltage regulation	$\pm 1.5\%$
Output voltage ripple	< 120 mV pk-pk

The target full-load efficiency is 89% based on a nominal input voltage of 24 V and an isolated output voltage of 12 V. The LM25183-Q1 is chosen to deliver a fixed 12-V output voltage set by resistor R_{FB} connected between the SW and FB pins. The input voltage turnon and turnoff thresholds are established by R_{UV1} and R_{UV2} . The required components are listed in [Table 2](#). Transformers for other single-output designs are listed in [Table 3](#).

Table 2. List of Components for Design 1

REF DES	QTY	SPECIFICATION	VENDOR	PART NUMBER
C_{IN}	1	10 μ F, 50 V, X7R, 1210, ceramic	TDK	C3225X7R1H106M250AC
C_{OUT1}	3	22 μ F, 25 V, X7R, 1210, ceramic	TDK	C3225X7R1E226M250AB
			Taiyo Yuden	TMK325B7226MM-PR
		22 μ F, 25 V, X7R, 1210, ceramic	Würth Elektronik	885012209074
C_{OUT2}	0	100 μ F, 16 V, $\pm 20\%$, electrolytic	Kemet	T598D107M016ATE050
C_{SS}	1	47 nF, 16 V, X7R, 0402	Std	Std
D_{CLAMP}	1	Zener, 20 V, 3 W, SMA	3SMAJ5932B	Micro Commercial
D_F, D_{FLY}	2	Schottky diode, 60 V, 3 A, SOD-123FL	FSV360FP	OnSemi
D_{OUT}	1	Zener, 13 V, 2%, SOD-523	BZX585-B13	Nexperia
R_{FB}	1	121 k Ω , 1%, 0402	Std	Std
R_{SET}	1	12.1 k Ω , 1%, 0402	Std	Std
R_{TC}	1	261 k Ω , 1%, 0402	Std	Std
R_{UV1}	1	261 k Ω , 1%, 0603	Std	Std
R_{UV2}	1	97.6 k Ω , 1%, 0402	Std	Std
T_1	1	12.5 μ H, 3 A, 1 : 1, 13 mm \times 11 mm \times 10 mm	Coilcraft	ZB1053-AE
U_1	1	LM25183-Q1 PSR flyback converter, AEC-Q100	Texas Instruments	LM25183QNGURQ1

ADVANCE INFORMATION
Table 3. Magnetic Components for Single-Output Designs

OUTPUT VOLTAGE RANGE	TURNS RATIO	L_{MAG}, I_{SAT}	DIMENSIONS	VENDOR	PART NUMBER
Up to 3.6 V	4 : 1	12.5 μ H, 3 A	13 \times 11 \times 10 mm	Coilcraft	ZB1050-AE
3.6 V to 5 V	3 : 1	14 μ H, 3 A			ZB1051-AE
5 V to 8 V	2 : 1	14 μ H, 3 A			ZB1052-AE
8 V to 15 V	1 : 1	12.5 μ H, 3 A			ZB1053-AE
15 V to 28 V	1 : 2	12.5 μ H, 3 A			ZB1054-AE
28 V to 50 V	1 : 3	14 μ H, 3 A			ZB1055-AE

8.2.1.2 Detailed Design Procedure

8.2.1.2.1 Custom Design With WEBENCH® Tools

Click [here](#) to create a custom design using the LM25183 -Q1 device with WEBENCH® Power Designer.

1. Start by entering the input voltage (V_{IN}), output voltage (V_{OUT}), and output current (I_{OUT}) requirements.
2. Optimize the design for key parameters such as efficiency, footprint, and cost using the optimizer dial.
3. Compare the generated design with other possible solutions from Texas Instruments.

The WEBENCH Power Designer provides a customized schematic along with a list of materials with real-time pricing and component availability.

In most cases, these actions are available:

- Run electrical simulations to see important waveforms and circuit performance
- Run thermal simulations to understand board thermal performance
- Export customized schematic and layout into popular CAD formats
- Print PDF reports for the design, and share the design with colleagues

Get more information about WEBENCH tools at www.ti.com/WEBENCH.

8.2.1.2.2 Custom Design With Excel Quickstart Tool

Select components based on the converter specifications using the LM25183-Q1 [quick-start calculator](#).

8.2.1.2.3 Flyback Transformer – T_1

Choose a turns ratio of 1 : 1 based on an approximate 70% max duty cycle at minimum input voltage using [Equation 14](#), rounding up or down as needed. While the maximum duty cycle can approach 80% if needed a particularly wide input voltage application, it increases the peak current stress of the secondary-side components.

$$N_{PS} = \frac{D_{MAX}}{1 - D_{MAX}} \cdot \frac{V_{IN(min)}}{V_{OUT} + V_D} = \frac{0.7}{1 - 0.7} \cdot \frac{5V}{12V + 0.3V} = 0.95 \quad (14)$$

Select a magnetizing inductance based on the minimum off-time constraint using [Equation 15](#). Choose a value of 12.5 μ H to allow some margin for this application. Specify a saturation current of 3 A, above the maximum switch current specification of the LM25183 -Q1.

$$L_{MAG} \geq \frac{(V_{OUT} + V_D) \cdot N_{PS} \cdot t_{OFF-MIN}}{I_{SW-PEAK(FFM)}} = \frac{(12V + 0.3V) \cdot 1 \cdot 375ns}{0.5A} = 9.2\mu H \quad (15)$$

Note that a higher magnetizing inductance provides a larger operating range for BCM and FFM, but the leakage inductance can increase based on a higher number of primary turns, N_p . [Equation 16](#) and [Equation 17](#) give the primary and secondary winding RMS currents, respectively.

$$I_{PRI-RMS} = \sqrt{\frac{D}{3}} \cdot I_{PRI-PK} \quad (16)$$

$$I_{SEC-RMS} = \sqrt{\frac{2 \cdot I_{OUT} \cdot I_{PRI-PK} \cdot N_{PS}}{3}} \quad (17)$$

Find the maximum output current for a given turns ratio using [Equation 18](#), where the typical value for $I_{SW-PEAK}$ is the 2.5-A switch peak current threshold. Iterate by increasing the turns ratio if the output current capability is too low at minimum input voltage, checking that the SW voltage rating of 65 V is not exceeded at maximum input voltage.

$$I_{OUT(max)} = \frac{I_{SW-PEAK}}{2 \cdot \left[\frac{V_{OUT} + V_D}{V_{IN}} + \frac{1}{N_{PS}} \right]} = \frac{2.5A}{2 \cdot \left[\frac{12V + 0.4V}{V_{IN}} + \frac{1}{1} \right]} = \begin{cases} 0.65A & \text{at } V_{IN} = 13.5V \\ 0.82A & \text{at } V_{IN} = 24V \end{cases} \quad (18)$$

8.2.1.2.4 Flyback Diode – D_{FLY}

The flyback diode reverse voltage is given by Equation 19.

$$V_{D-REV} \geq \frac{V_{IN(max)}}{N_{PS}} + V_{OUT} = \frac{42V}{1} + 12V = 54V \quad (19)$$

Select a 60-V, 3-A Schottky diode for this application to account for inevitable diode voltage overshoot and ringing related to the resonance of transformer leakage inductance and diode parasitic capacitance. Connect an appropriate RC snubber circuit (for example, 100 Ω and 22 pF) across the flyback diode if needed, particularly if the transformer leakage inductance is high. Also, choose a flyback diode with current rating that aligns with the maximum peak secondary winding current of $N_{PS} \times I_{SW-PEAK}$.

8.2.1.2.5 Leakage Inductance Clamp Circuit – D_F, D_{CLAMP}

Connect a diode-Zener clamp circuit across the primary winding to limit the peak switch voltage after MOSFET turnoff below the maximum level of 65 V, as given by Equation 20.

$$V_{DZ(clamp)} < V_{SW(max)} - V_{IN(max)} \quad (20)$$

Choose a 20-V zener diode for D_{CLAMP} to give a clamp voltage of approximately 1.5 times the reflected output voltage, as specified by Equation 21. This provides a balance between the maximum switch voltage excursion and the leakage inductance demagnetization time. Select a Zener diode with low package parasitic inductance to manage the high slew-rate current during the switch turnoff transition.

$$V_{DZ(clamp)} = 1.5 \cdot N_{PS} \cdot (V_{OUT} + V_D) = 1.5 \cdot 1 \cdot (12V + 0.4V) = 18.6V \quad (21)$$

Choose an ultra-fast switching diode or Schottky diode for D_F with reverse voltage rating greater than the maximum input voltage and forward current rating of 2 A or higher.

8.2.1.2.6 Output Capacitor – C_{OUT}

The output capacitor determines the voltage ripple at the converter output, limits the voltage excursion during a load transient, and sets the dominant pole of the small-signal response of the converter. Select an output capacitance using Equation 22 to limit the ripple voltage amplitude to less than 1% of the output voltage at minimum input voltage and maximum load.

$$C_{OUT} \geq \frac{L_{MAG} \cdot I_{SW-PEAK}^2}{2 \cdot \Delta V_{OUT} \cdot V_{OUT}} \cdot \left(\frac{1+D}{2}\right)^2 = \frac{12.5\mu H \cdot (2.5A)^2}{2 \cdot 120mV \cdot 12V} \cdot \left(\frac{1+0.7}{2}\right)^2 = 20\mu F \quad (22)$$

Mindful of the voltage coefficient of ceramic capacitors, select three 22-μF, 25-V capacitors in 1210 case size with X7S or better dielectric. Assuming operation in BCM, calculate the capacitive ripple voltage at the output using Equation 23.

$$\Delta V_{OUT} = \frac{L_{MAG} \cdot I_{OUT}^2}{2 \cdot C_{OUT} \cdot V_{OUT} \cdot N_{PS}^2} \cdot \left(\frac{1+D}{1-D}\right)^2 = \frac{L_{MAG} \cdot I_{OUT}^2}{2 \cdot \Delta V_{OUT} \cdot V_{OUT}} \cdot \left[\frac{1}{N_{PS}} + \frac{2 \cdot (V_{OUT} + V_D)}{V_{IN}}\right]^2 \quad (23)$$

Equation 24 gives an expression for the output capacitor RMS ripple current.

$$I_{COUT-RMS} = I_{OUT} \cdot \sqrt{\frac{2 \cdot N_{PS} \cdot I_{PRI-PK} - 1}{3 \cdot I_{OUT}}} \quad (24)$$

8.2.1.2.7 Input Capacitor – C_{IN}

Select an input capacitance using Equation 25 to limit the ripple voltage amplitude to less than 5% of the input voltage when operating at nominal input voltage.

$$C_{IN} \geq \frac{I_{PRI-PK} \cdot D \cdot \left(1 - \frac{D}{2}\right)^2}{2 \cdot F_{SW} \cdot \Delta V_{IN}} \quad (25)$$

Substituting the input current at full load, switching frequency, peak primary current, and peak-to-peak ripple specification gives C_{IN} greater than 5 μF . Considering the voltage coefficient of ceramic capacitors, select a 10- μF , 50-V, X7R ceramic capacitor in 1210 case size. Equation 26 gives the input capacitor RMS ripple current.

$$I_{CIN-RMS} = \frac{D \cdot I_{PRI-PK}}{2} \cdot \sqrt{\frac{4}{3 \cdot D} - 1} \quad (26)$$

8.2.1.2.8 Feedback Resistor – R_{FB}

Select a feedback resistor, designated R_{FB} , of 121 k Ω based on the secondary winding voltage at the end of the flyback conduction interval (the sum of the 12-V output voltage and the Schottky diode forward voltage drop as its current approaches zero) reflected by the transformer turns ratio of 1 : 1.

$$R_{FB} = \frac{(V_{OUT} + V_D) \cdot N_{PS}}{0.1 \text{ mA}} = \frac{(12 \text{ V} + 0.2 \text{ V}) \cdot 1}{0.1 \text{ mA}} = 122 \text{ k}\Omega \quad (27)$$

8.2.1.2.9 Thermal Compensation Resistor – R_{TC}

Select a resistor for output voltage thermal compensation, designated R_{TC} , based on Equation 28.

$$R_{TC} [\text{k}\Omega] = \frac{R_{FB} [\text{k}\Omega]}{N_{PS}} \cdot \frac{3}{TC_{Diode} [\text{mV}/^\circ\text{C}]} = \frac{121 \text{ k}\Omega \cdot 3}{1 \cdot 1.4} = 261 \text{ k}\Omega \quad (28)$$

8.2.1.2.10 UVLO Resistors – R_{UV1} , R_{UV2}

Given $V_{IN(on)}$ and $V_{IN(off)}$ as the input voltage turnon and turnoff thresholds of 5.5 V and 4 V, respectively, select the upper and lower UVLO resistors using the following expressions:

$$R_{UV1} = \frac{V_{IN(on)} \cdot \frac{V_{UV-FALLING} - V_{IN(off)}}{V_{UV-RISING}}}{I_{UV-HYST}} = \frac{5.5 \text{ V} \cdot \frac{1.45 \text{ V} - 4 \text{ V}}{1.5 \text{ V}}}{5 \mu\text{A}} = 263 \text{ k}\Omega \quad (29)$$

$$R_{UV2} = R_{UV1} \cdot \frac{V_{UV-RISING}}{V_{IN(on)} - V_{UV-RISING}} = 263 \text{ k}\Omega \cdot \frac{1.5 \text{ V}}{5.5 \text{ V} - 1.5 \text{ V}} = 98.6 \text{ k}\Omega \quad (30)$$

The nearest standard E96 resistor values for R_{UV1} and R_{UV2} are 261 k Ω and 97.6 k Ω , respectively. Calculate the actual input voltage turnon and turnoff thresholds as follows:

$$V_{IN(on)} = V_{UV-RISING} \left(1 + \frac{R_{UV1}}{R_{UV2}}\right) = 1.5 \text{ V} \left(1 + \frac{261 \text{ k}\Omega}{97.6 \text{ k}\Omega}\right) = 5.51 \text{ V} \quad (31)$$

$$V_{IN(off)} = V_{UV-FALLING} \left(1 + \frac{R_{UV1}}{R_{UV2}}\right) - I_{UV-HYST} \cdot R_{UV1} = 1.45 \text{ V} \left(1 + \frac{261 \text{ k}\Omega}{97.6 \text{ k}\Omega}\right) - 5 \mu\text{A} \cdot 261 \text{ k}\Omega = 4.02 \text{ V} \quad (32)$$

8.2.1.2.11 Soft-Start Capacitor – C_{SS}

Connect an external soft-start capacitor for a specific soft-start time. In this example, select a soft-start capacitance of 47 nF based on Equation 12 to achieve a soft-start time of 9 ms.

For technical solutions, industry trends, and insights for designing and managing power supplies, please refer to TI's [Power Management](#) technical articles.

8.2.2 Application Curves

Unless otherwise stated, application performance curves were taken at $T_A = 25^\circ\text{C}$.

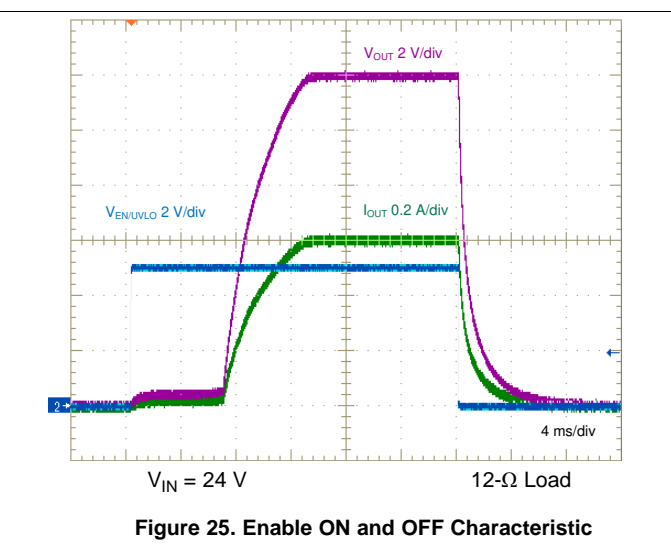
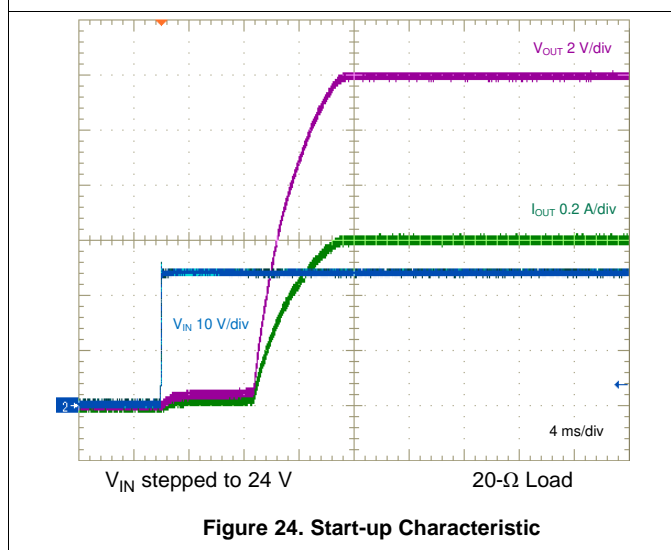
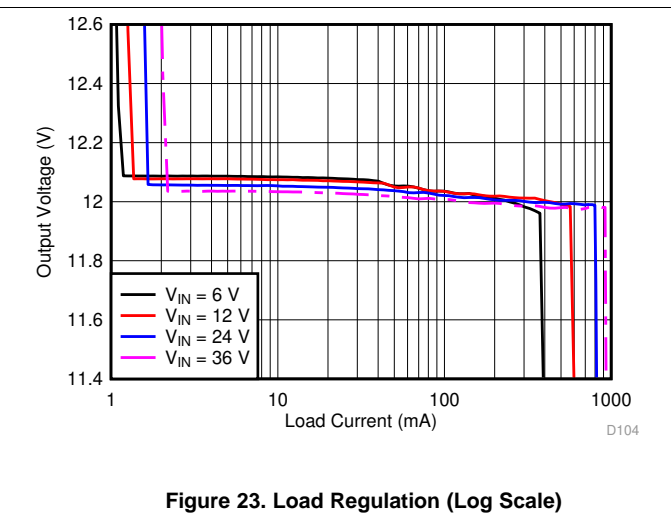
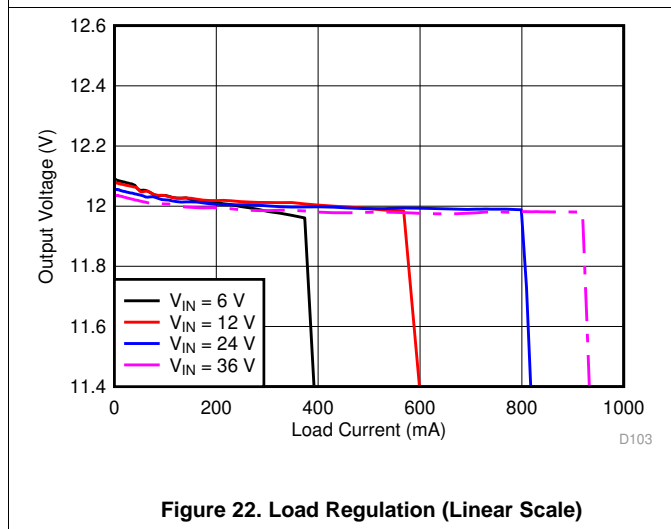
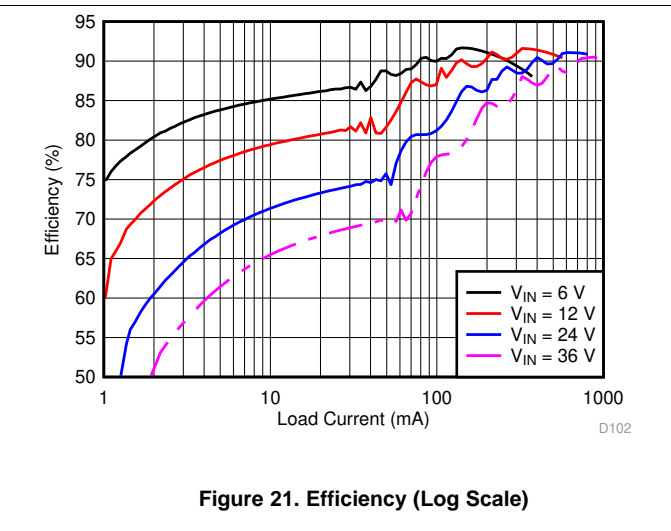
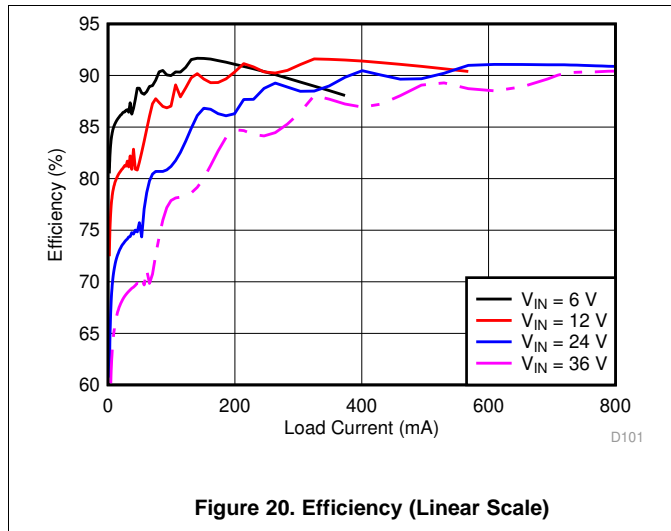

ADVANCE INFORMATION

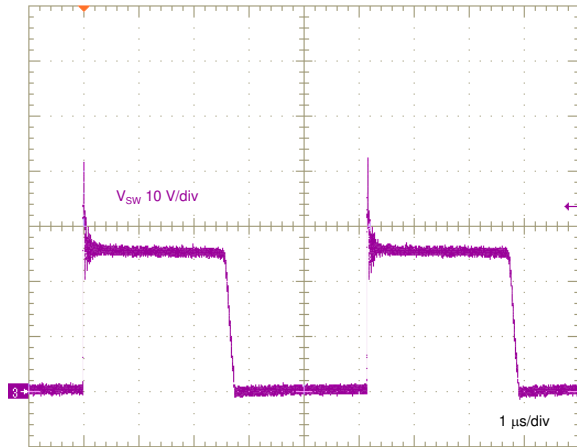

$V_{IN} = 13.5\text{ V}$ $I_{OUT} = 0.6\text{ A}$

Figure 26. Switch Node Voltage

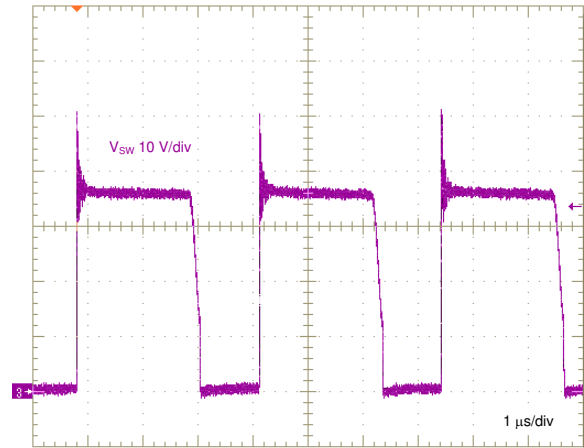

$V_{IN} = 24\text{ V}$ $I_{OUT} = 0.6\text{ A}$

Figure 27. Switch Node Voltage

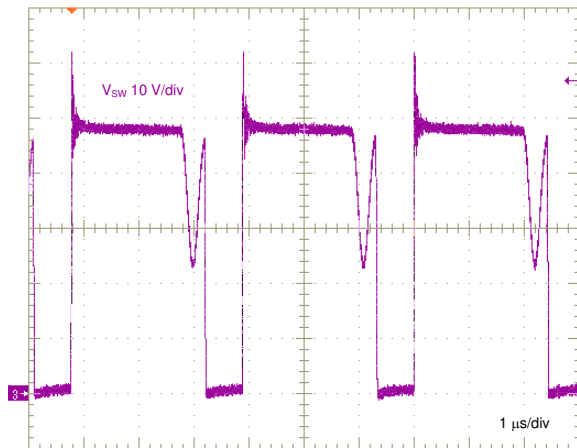

$V_{IN} = 36\text{ V}$ $I_{OUT} = 0.6\text{ A}$

Figure 28. Switch Node Voltage

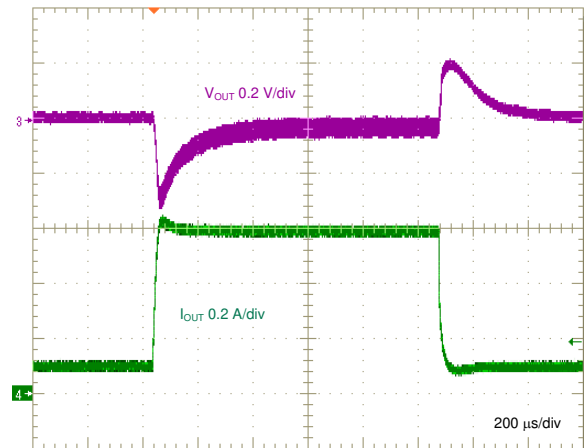

$V_{IN} = 24\text{ V}$

Figure 29. Load Transient, 0.1 A to 0.6 A, 0.1 A/μs

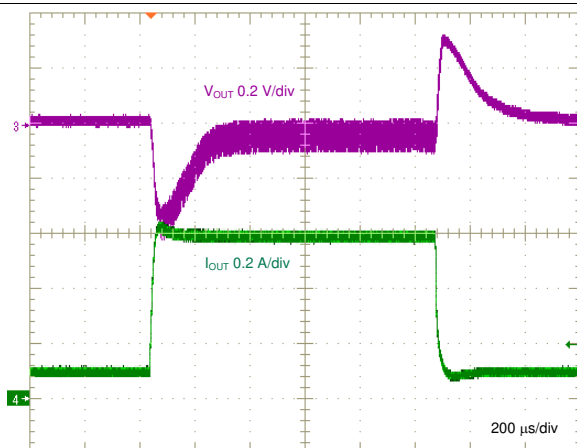

$V_{IN} = 13.5\text{ V}$

Figure 30. Load Transient, 0.1 A to 0.6 A, 0.1 A/μs

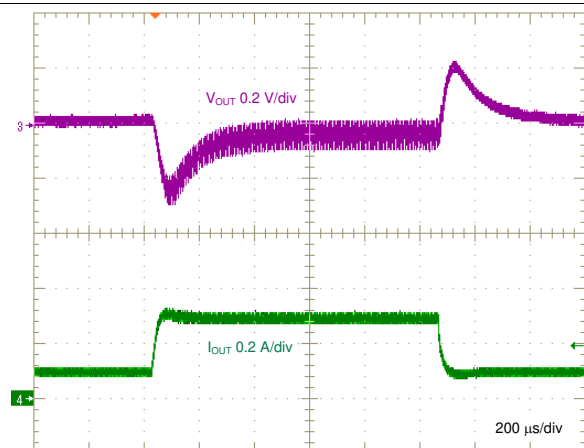

$V_{IN} = 6\text{ V}$

Figure 31. Load Transient, 0.1 A to 0.3 A, 0.1 A/μs

ADVANCE INFORMATION

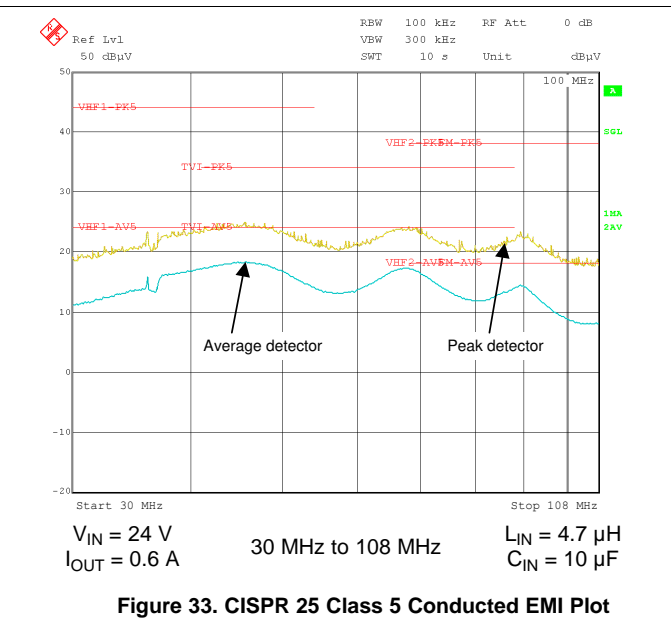
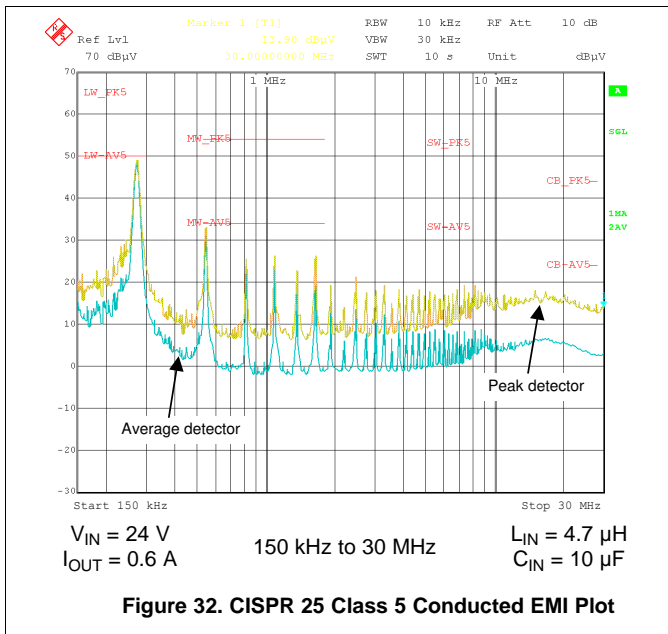

8.2.3 Design 2: PSR Flyback Converter With Dual Outputs of 15 V and –15 V at 0.3 A

The schematic diagram of a dual-output flyback converter intended for isolated IGBT and SiC MOSFET gate drive power supply applications is given in [Figure 34](#).

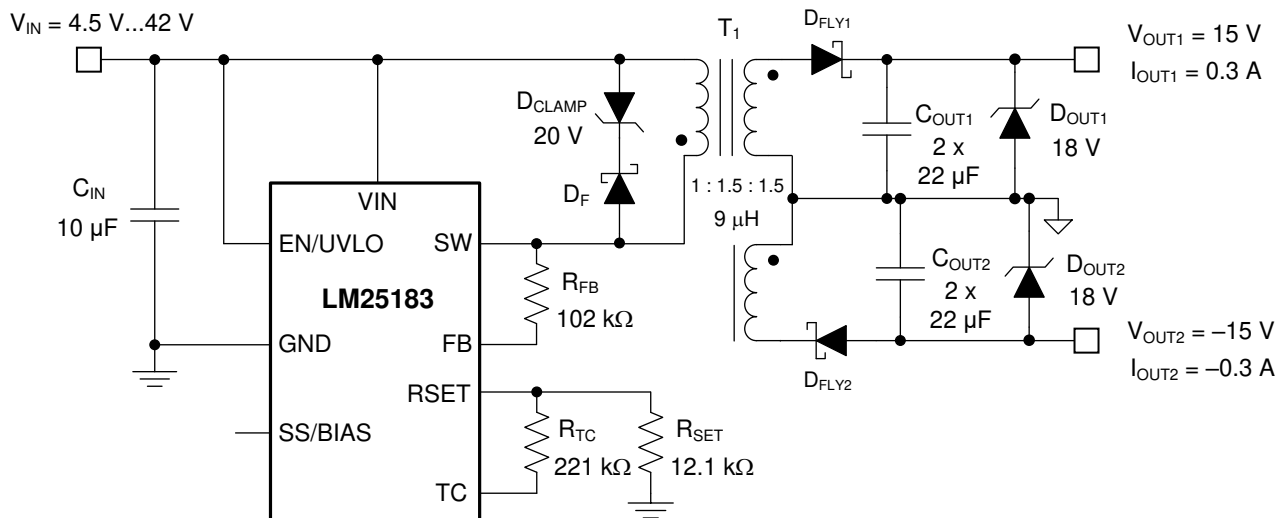

Figure 34. Schematic for Design 2 With $V_{IN(nom)} = 13.5\text{ V}$, $V_{OUT1} = 15\text{ V}$, $V_{OUT2} = -15\text{ V}$, $I_{OUT} = 0.3\text{ A}$

8.2.3.1 Design Requirements

The required input, output, and performance parameters for this application example are shown in [Table 4](#).

Table 4. Design Parameters

DESIGN PARAMETER	VALUE
Input voltage range (steady state)	4.5 V to 42 V
Output 1 voltage and current (at $V_{IN} \geq 24\text{ V}$)	15 V, 0.3 A
Output 2 voltage and current (at $V_{IN} \geq 24\text{ V}$)	-15 V, 0.3 A
Input UVLO thresholds	4.5 V on, 4 V off
Output voltage regulation	±2%

The target full-load efficiency of this LM25183-Q1 design is 90% based on a nominal input voltage of 13.5 V and isolated output voltages of 15 V and –15 V sharing a common return. The selected flyback converter components are cited in [Table 5](#), including the following:

- A multi-winding flyback transformer
- Input and output capacitors
- Flyback rectifying diodes
- A flyback converter IC

Table 5. List of Components for Design 2

REF DES	QTY	SPECIFICATION	VENDOR	PART NUMBER
C _{IN}	1	10 μF, 50 V, X7R, 1210, ceramic, AEC-Q200	TDK	CNA6P1X7R1H106K250AE
			Taiyo Yuden	UMJ325KB7106KMHP
C _{OUT1} , C _{OUT2}	4	22 μF, 25 V, X7R, 1210, ceramic, AEC-Q200	TDK	CGA6P3X7R1E226M250AB
			Taiyo Yuden	TMK325B7226KMHT
D _{CLAMP}	1	Zener, 20 V, 3 W, SMA	3SMAJ5932B	Micro Commercial
D _F	1	Schottky diode, 60 V, 3 A, SOD-123FL	FSV360FP	OnSemi
D _{FLY1} , D _{FLY2}	2	Schottky diode, 100 V, 1 A, POWERDI123	DFLS1100-7	Diodes Inc.
D _{OUT1} , D _{OUT2}	2	Zener, 18 V, 5%, SOD-523, AEC-Q101	BZX585-C18	Nexperia
R _{FB}	1	102 kΩ, 1%, 0402	Std	Std
R _{SET}	1	12.1 kΩ, 1%, 0402	Std	Std
R _{TC}	1	221 kΩ, 1%, 0402	Std	Std
T ₁	1	9 μH, 3 A, 1 : 1.5 : 1.5, 13 mm × 11 mm × 10 mm	Coilcraft	ZB1056-AE
U ₁	1	LM25183-Q1 PSR flyback converter, VSON-8, AEC-Q100	Texas Instruments	LM25183QNGURQ1

8.2.3.2 Detailed Design Procedure

Using the LM25183-Q1 [quick-start calculator](#), components are selected based on the flyback converter specifications.

8.2.3.2.1 Flyback Transformer – T₁

Choose a primary-secondary turns ratio for a 15-V output based on an approximate 70% max duty cycle at minimum input voltage using [Equation 33](#). The transformer turns ratio when considering both outputs is thus specified as 1 : 1.5 : 1.5.

$$N_{PS} = \frac{D_{MAX}}{1 - D_{MAX}} \cdot \frac{V_{IN(min)}}{V_{OUT} + V_D} = \frac{0.7}{1 - 0.7} \cdot \frac{4.5 V}{15 V + 0.3 V} = 0.69 \quad (33)$$

Select a magnetizing inductance based on the minimum off-time constraint using [Equation 34](#). Choose a value of 9 μH and a saturation current of 3 A for this application.

$$L_{MAG} \geq \frac{(V_{OUT} + V_D) \cdot N_{PS} \cdot t_{OFF-MIN}}{I_{SW-PEAK(FFM)}} = \frac{(15 V + 0.3 V) \cdot 1/1.5 \cdot 375 ns}{0.5 A} = 7.7 \mu H \quad (34)$$

Find the maximum output current for a given turns ratio, assuming the outputs are symmetrically loaded, using [Equation 35](#).

$$I_{OUT(max)} = \frac{I_{SW-PEAK}}{2 \cdot \left[\frac{V_{OUT} + V_D}{V_{IN}} + \frac{1}{N_{PS}} \right]} = \frac{2.5 A}{2 \cdot \left[\frac{30 V + 0.4 V}{V_{IN}} + \frac{1}{(1/3)} \right]} = \begin{cases} 0.24 A \text{ at } V_{IN} = 13.5 V \\ 0.29 A \text{ at } V_{IN} = 24 V \end{cases} \quad (35)$$

8.2.3.2.2 Flyback Diodes – D_{FLY1} and D_{FLY2}

The flyback diode reverse voltages for the positive and negative outputs are given respectively by [Equation 36](#) and [Equation 37](#).

$$V_{D1-REV} \geq \frac{V_{IN(max)}}{N_{PS1}} + V_{OUT1} = \frac{42 V}{(1/1.5)} + 15 V = 79 V \quad (36)$$

$$V_{D2-REV} \geq \frac{V_{IN(max)}}{N_{PS2}} + V_{OUT2} = \frac{42 V}{(1/1.5)} + 15 V = 79 V \quad (37)$$

Choose a 100-V, 2-A Schottky diode for each output to allow some margin for inevitable voltage overshoot and ringing related to leakage inductance and diode capacitance. Use an RC snubber circuit across each diode, for example, 100 Ω and 22 pF, to mitigate such overshoot and ringing, particularly if the transformer leakage inductance is high.

8.2.3.2.3 Input Capacitor – C_{IN}

The input capacitor filters the primary-winding current waveform. To prevent large ripple voltage, use a low-ESR ceramic input capacitor sized according to [Equation 25](#) for the RMS ripple current given by [Equation 26](#). In this design example, choose a 10- μ F, 50-V ceramic capacitor with X7R dielectric and 1210 footprint.

8.2.3.2.4 Output Capacitors – C_{OUT1} , C_{OUT2}

The output capacitors determine the voltage ripple at the converter outputs, limit the voltage excursion during a load transient, and set the dominant pole of the small-signal response of the converter.

Mindful of the voltage coefficient of ceramic capacitors, select two 22- μ F, 25-V, X7R capacitors in 1210 case size for each output.

8.2.3.2.5 Feedback Resistor – R_{FB}

Install a 102-k Ω resistor from SW to FB based on an output voltage setpoint of 15 V (plus a flyback diode voltage drop) reflected to the primary side by a transformer turns ratio of 1 : 1.5.

$$R_{FB} = \frac{(V_{OUT1} + V_{D1}) \cdot N_{PS1}}{0.1 \text{ mA}} = \frac{(15 \text{ V} + 0.3 \text{ V}) \cdot (1/1.5)}{0.1 \text{ mA}} = 102 \text{ k}\Omega \quad (38)$$

8.2.3.2.6 Thermal Compensation Resistor – R_{TC}

Select a resistor value for output voltage thermal compensation based on [Equation 39](#).

$$R_{TC} [\text{k}\Omega] = \frac{R_{FB} [\text{k}\Omega]}{N_{PS}} \cdot \frac{3}{TC_{Diode} [\text{mV}/^\circ\text{C}]} = \frac{102 \text{ k}\Omega \cdot 3}{(1/1.5) \cdot 2} = 230 \text{ k}\Omega \quad (39)$$

8.2.3.2.7 Output Voltage Clamp Zeners – D_{OUT1} and D_{OUT2}

Calculate the power delivered to the output at no load based on [Equation 40](#).

$$P_{OUT(\min)} = \frac{L_{MAG} \cdot I_{SW-PEAK(FFM)}^2}{2} \cdot F_{SW(\min)} = \frac{9 \mu\text{H} \cdot (0.5 \text{ A})^2}{2} \cdot 12 \text{ kHz} = 14 \text{ mW} \quad (40)$$

Select Zener clamp diodes to limit the voltages to a range of 110% to 120% of the nominal output voltage setpoints during no-load operation. Connect an 18-V Zener diode with $\pm 2\%$ tolerance and SOD-523 package across each output.

8.2.3.3 Application Curves

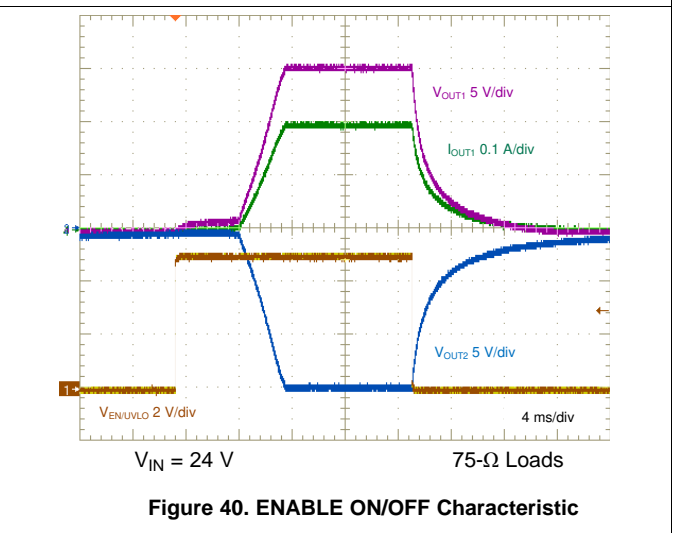
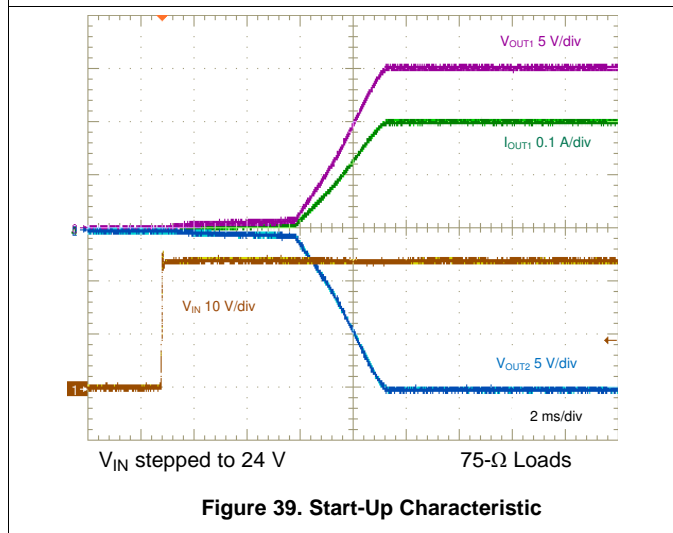
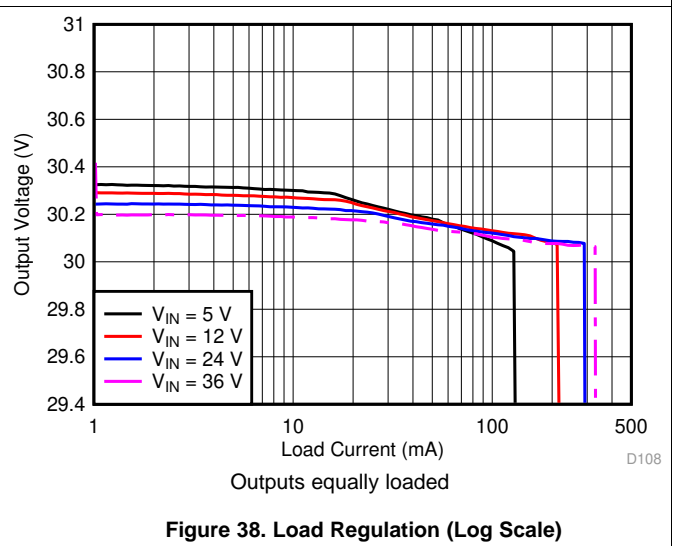
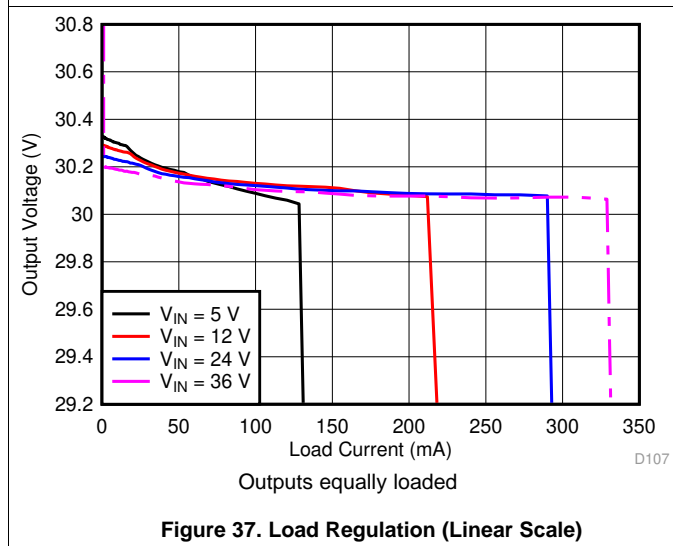
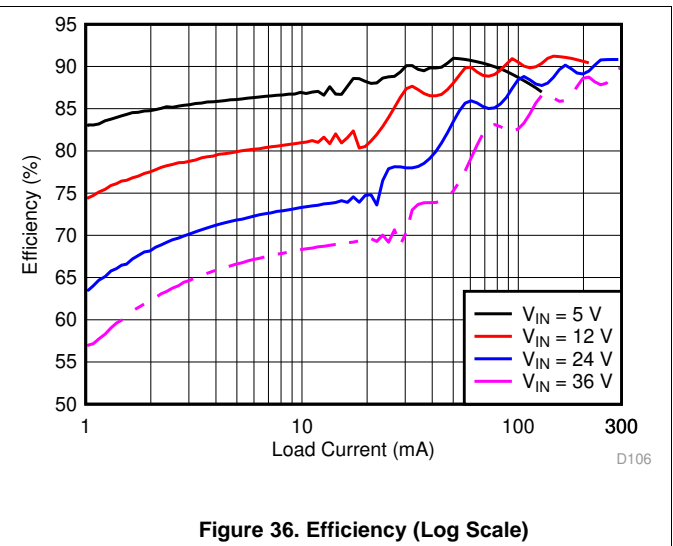
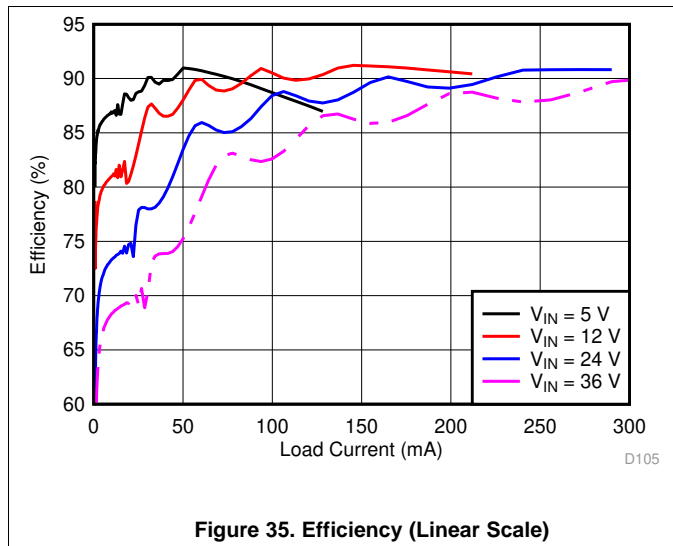

ADVANCE INFORMATION

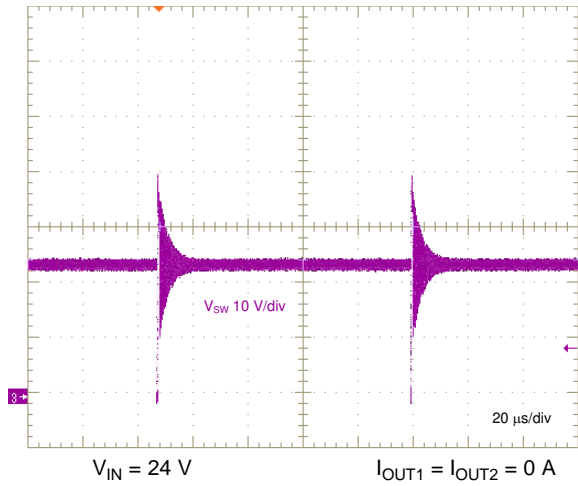

Figure 41. Switch Voltage, No Load

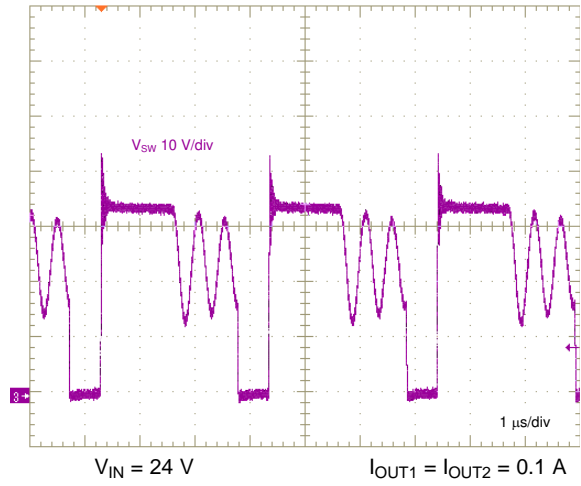

Figure 42. Switch Voltage, Medium Load

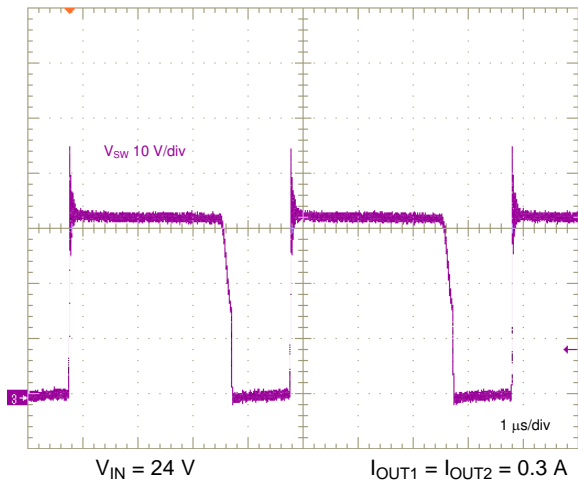

Figure 43. Switch Voltage, Full Load

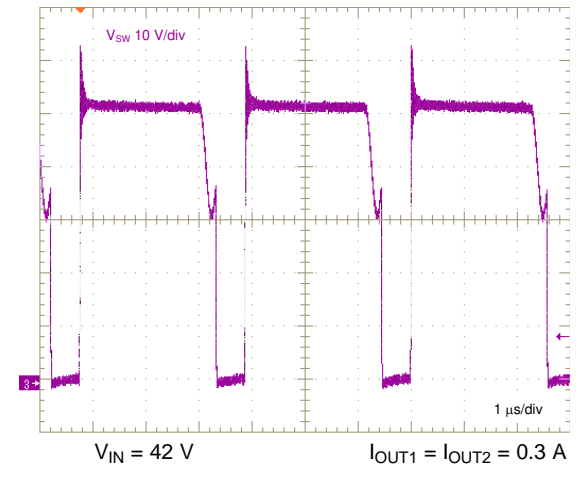

Figure 44. Switch Voltage, Full Load

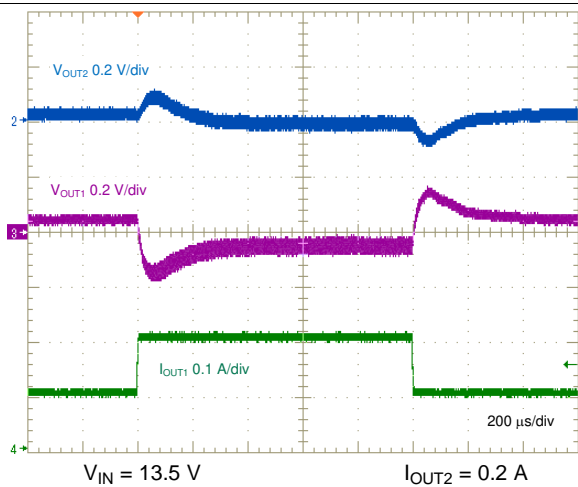

Figure 45. Positive Output Load Transient, 0.1 A to 0.2 A

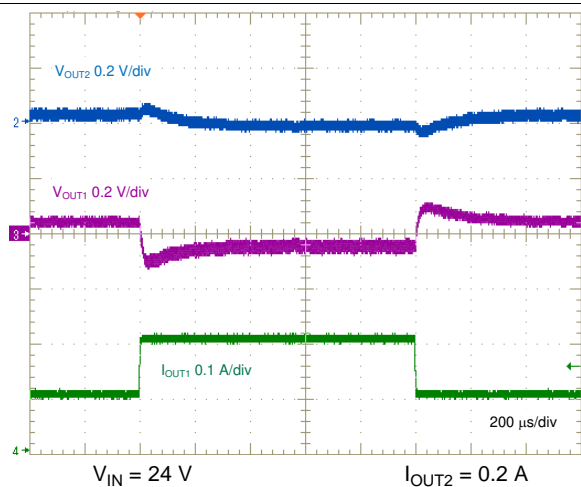

Figure 46. Positive Output Load Transient, 0.1 A to 0.2 A

9 Power Supply Recommendations

The LM25183-Q1 flyback converter operates over a wide input voltage range from 4.5 V to 42 V. The characteristics of the input supply must be compatible with the [Absolute Maximum Ratings](#) and [Recommended Operating Conditions](#). In addition, the input supply must be capable of delivering the required input current to the fully-loaded regulator. Estimate the average input current with [Equation 41](#).

$$I_{IN} = \frac{V_{OUT} \cdot I_{OUT}}{V_{IN} \cdot \eta}$$

where

- η is the efficiency (41)

If the converter is connected to an input supply through long wires or PCB traces with a large impedance, special care is required to achieve stable performance. The parasitic inductance and resistance of the input cables can have an adverse effect on converter operation. The parasitic inductance in combination with the low-ESR ceramic input capacitors form an underdamped resonant circuit. This circuit can cause overvoltage transients at VIN each time the input supply is cycled ON and OFF. The parasitic resistance causes the input voltage to dip during a load transient. If the regulator is operating close to the minimum input voltage, this dip can cause false UVLO fault triggering and a system reset. The best way to solve such issues is to reduce the distance from the input supply to the regulator and use an aluminum electrolytic input capacitor in parallel with the ceramics. The moderate ESR of the electrolytic capacitors helps damp the input resonant circuit and reduce any voltage overshoots. A capacitance in the range of 22 μ F to 100 μ F is usually sufficient to provide input damping and helps to hold the input voltage steady during large load transients. A typical ESR of 200 m Ω provides enough damping for most input circuit configurations.

An EMI input filter is often used in front of the regulator that, unless carefully designed, can lead to instability as well as some of the effects mentioned above. The application report [Simple Success with Conducted EMI for DC-DC Converters](#) provides helpful suggestions when designing an input filter for any switching regulator.

10 Layout

The performance of any switching converter depends as much upon PCB layout as it does the component selection. The following guidelines are provided to assist with designing a PCB with the best power conversion performance, thermal performance, and minimized generation of unwanted EMI. [Figure 47](#) and [Figure 48](#) provide layout examples for single-output and dual-output designs, respectively.

10.1 Layout Guidelines

PCB layout is critical for good power supply design. There are several paths that conduct high slew-rate currents or voltages that can interact with transformer leakage inductance or parasitic capacitance to generate noise and EMI or degrade the performance of the power supply.

1. Bypass VIN to GND with a low-ESR ceramic capacitor, preferably of X7R or X7S dielectric. Place C_{IN} as close as possible to the LM25184 VIN and GND pins. Ground return paths for the input capacitor or capacitors must consist of localized top-side planes that connect to the GND pin and exposed PAD.
2. Minimize the loop area formed by the input capacitor connections and the VIN and GND pins.
3. Locate the transformer close to the SW pin. Minimize the area of the SW trace or plane to prevent excessive e-field or capacitive coupling.
4. Minimize the loop area formed by the diode-Zener clamp circuit connections and the primary winding terminals of the transformer.
5. Minimize the loop area formed by the flyback rectifying diode, output capacitor, and the secondary winding terminals of the transformer.
6. Tie the GND pin directly to the DAP under the device and to a heat-sinking PCB ground plane.
7. Use a ground plane in one of the middle layers as a noise shielding and heat dissipation path.
8. Have a single-point ground connection to the plane. Route the return connections for the reference resistor, soft start, and enable components directly to the GND pin. This prevents any switched or load currents from flowing in analog ground traces. If not properly handled, poor grounding results in degraded load regulation or erratic output voltage ripple behavior.
9. Make V_{IN+} , V_{OUT+} , and ground bus connections short and wide. This reduces any voltage drops on the input or output paths of the converter and maximizes efficiency.
10. Minimize trace length to the FB pin. Locate the feedback resistor close to the FB pin.
11. Locate components R_{SET} , R_{TC} , and C_{SS} as close as possible to their respective pins. Route with minimal trace lengths.
12. Place a capacitor between input and output return connections to route common-mode noise currents directly back to their source.
13. Provide adequate heatsinking for the LM25183-Q1 to keep the junction temperature below 150°C. For operation at full rated load, the top-side ground plane is an important heat-dissipating area. Use an array of heat-sinking vias to connect the DAP to the PCB ground plane. If the PCB has multiple copper layers, connect these thermal vias to inner-layer ground planes. The connection to V_{OUT+} provides heatsinking for the flyback diode.

10.2 Layout Examples

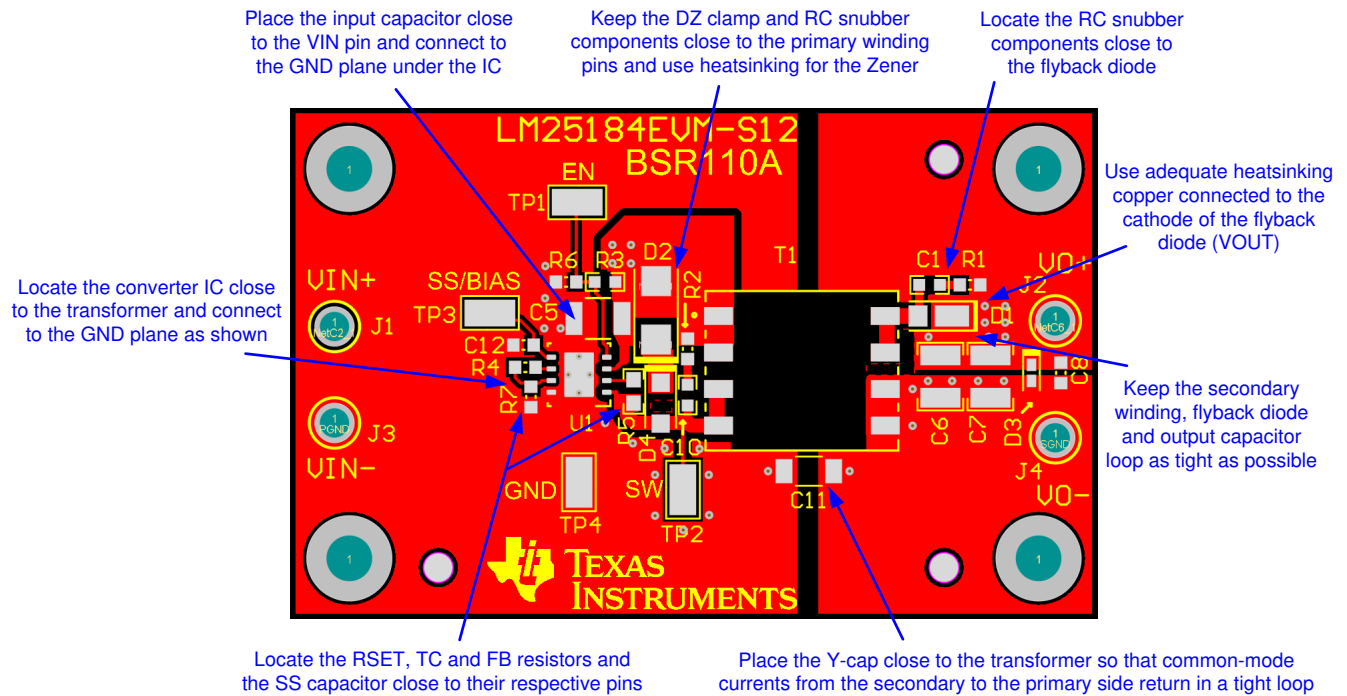

Figure 47. Single-Output PCB Layout Example

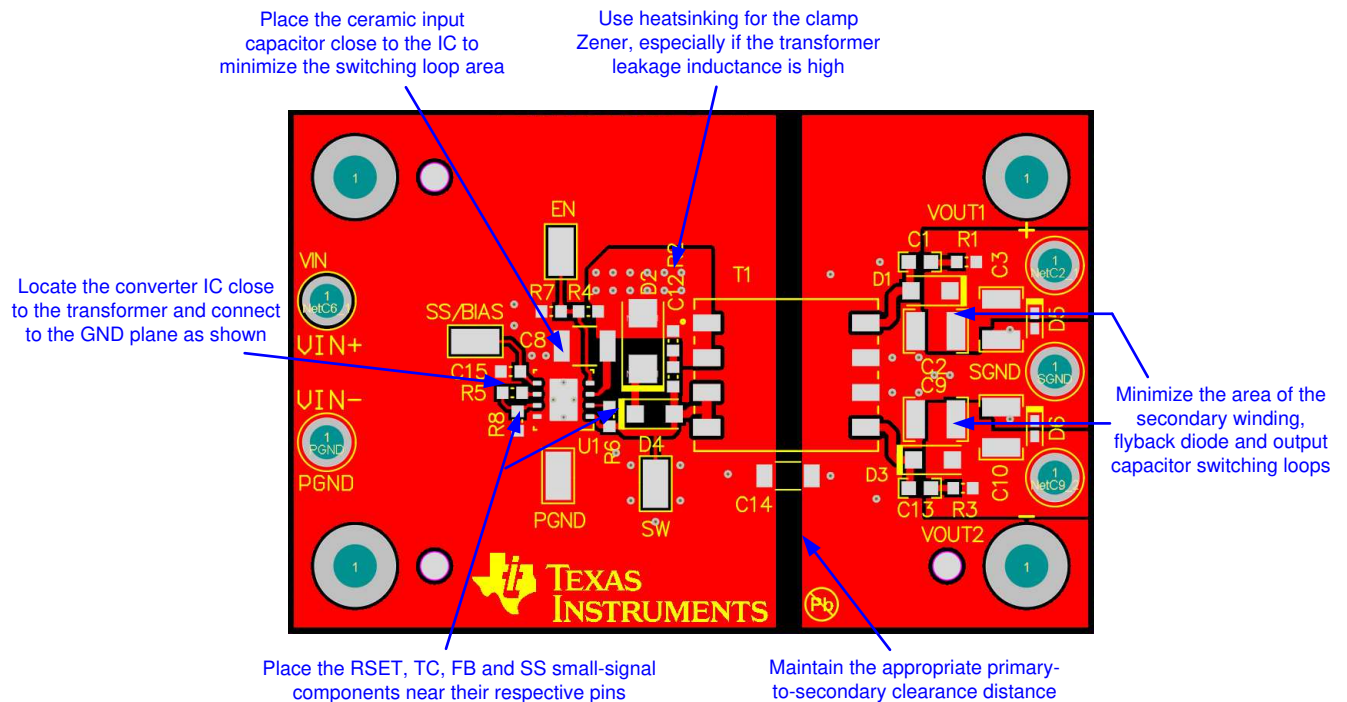

Figure 48. Dual-Output PCB Layout Example

ADVANCE INFORMATION

11 Device and Documentation Support

11.1 Device Support

11.1.1 Third-Party Products Disclaimer

TI'S PUBLICATION OF INFORMATION REGARDING THIRD-PARTY PRODUCTS OR SERVICES DOES NOT CONSTITUTE AN ENDORSEMENT REGARDING THE SUITABILITY OF SUCH PRODUCTS OR SERVICES OR A WARRANTY, REPRESENTATION OR ENDORSEMENT OF SUCH PRODUCTS OR SERVICES, EITHER ALONE OR IN COMBINATION WITH ANY TI PRODUCT OR SERVICE.

11.1.2 Development Support

With input voltage range and current capability as specified in [Table 6](#), the PSR flyback DC/DC converter family of parts from TI provides flexibility, scalability and optimized solution size for a range of applications. Using an 8-pin WSON package with 4-mm × 4-mm footprint and 0.8-mm pin pitch, these converters enable isolated DC/DC solutions with high density and low component count.

Table 6. PSR Flyback DC/DC Converter Family

PSR FLYBACK DC/DC CONVERTER	INPUT VOLTAGE RANGE	PEAK SWITCH CURRENT	MAXIMUM LOAD CURRENT, $V_{OUT} = 12\text{ V}$, $N_{PS} = 1$	
			$V_{IN} = 4.5\text{ V}$	$V_{IN} = 13.5\text{ V}$
LM5181-Q1	4.5 V to 65 V	0.75 A	90 mA	180 mA
LM5180-Q1	4.5 V to 65 V	1.5 A	180 mA	360 mA
LM25180-Q1	4.5 V to 42 V	1.5 A	180 mA	360 mA
LM25183-Q1	4.5 V to 42 V	2.5 A	300 mA	600 mA
LM25184-Q1	4.5 V to 42 V	4.1 A	500 mA	1 A

For development support, see the following:

- [LM25183-Q1 Quick-start Calculator](#)
- [LM25183-Q1 Simulation Models](#)
- For TI's reference design library, visit [TI Designs](#)
- For TI's WEBENCH Design Environment, visit the [WEBENCH® Design Center](#).
- To view a related device of this product, see the [LM25184-Q1 product page](#)
- TI Designs:
 - [Isolated IGBT Gate-Drive Power Supply Reference Design With Integrated Switch PSR Flyback Controller](#)
 - [Compact, Efficient, 24-V Input Auxiliary Power Supply Reference Design for Servo Drives](#)
 - [Reference Design for Power-Isolated Ultra-Compact Analog Output Module](#)
 - [HEV/EV Traction Inverter Power Stage with 3 Types of IGBT/SiC Bias-Supply Solutions Reference Design](#)
 - [4.5-V to 65-V Input, Compact Bias Supply With Power Stage Reference Design for IGBT/SiC Gate Drivers](#)
 - [Channel-to-Channel Isolated Analog Input Module Reference Design](#)
 - [SiC/IGBT Isolated Gate Driver Reference Design With Thermal Diode and Sensing FET](#)
 - [>95% Efficiency, 1-kW Analog Control AC/DC Reference Design for 5G Telecom Rectifier](#)
 - [3.5-W Automotive Dual-output PSR Flyback Regulator Reference Design](#)
- TI Technical Articles:
 - [Flyback Converters: Two Outputs are Better Than One](#)
 - [Common Challenges When Choosing the Auxiliary Power Supply for Your Server PSU](#)
 - [Maximizing PoE PD Efficiency on a Budget](#)

11.1.2.1 Custom Design With WEBENCH® Tools

Click [here](#) to create a custom design using the LM25183-Q1 device with WEBENCH® Power Designer.

1. Start by entering the input voltage (V_{IN}), output voltage (V_{OUT}), and output current (I_{OUT}) requirements.
2. Optimize the design for key parameters such as efficiency, footprint, and cost using the optimizer dial.
3. Compare the generated design with other possible solutions from Texas Instruments.

The WEBENCH Power Designer provides a customized schematic along with a list of materials with real-time pricing and component availability.

In most cases, these actions are available:

- Run electrical simulations to see important waveforms and circuit performance
- Run thermal simulations to understand board thermal performance
- Export customized schematic and layout into popular CAD formats
- Print PDF reports for the design, and share the design with colleagues

Get more information about WEBENCH tools at www.ti.com/WEBENCH.

11.2 Documentation Support

11.2.1 Related Documentation

For related documentation see the following:

- [LM25184 Single-Output EVM User's Guide](#) (SNVU680)
- [LM5180 Single-Output EVM User's Guide](#) (SNVU592)
- [LM5180 Dual-Output EVM User's Guide](#) (SNVU609)
- [How an Auxless PSR Flyback Converter can Increase PLC Reliability and Density](#) (SLYT779)
- [Why Use PSR-Flyback Isolated Converters in Dual-Battery mHEV Systems](#) (SLYT791)
- [IC Package Features Lead to Higher Reliability in Demanding Automotive and Communications Equipment Systems](#) (SNVA804)
- [PSR Flyback DC/DC Converter Transformer Design for mHEV Applications](#) (SNVA805)
- [Flyback Transformer Design Considerations for Efficiency and EMI](#) (SLUP338)
- [Under the Hood of Flyback SMPS Designs](#) (SLUP261)
- White Papers:
 - [Valuing Wide \$V_{IN}\$, Low EMI Synchronous Buck Circuits for Cost-driven, Demanding Applications](#) (SLYY104)
 - [An Overview of Conducted EMI Specifications for Power Supplies](#) (SLYY136)
 - [An Overview of Radiated EMI Specifications for Power Supplies](#) (SLYY142)
- [Using New Thermal Metrics Application Report](#) (SBVA025)
- [Semiconductor and IC Package Thermal Metrics Application Report](#) (SPRA953)
- [AN-2162: Simple Success with Conducted EMI from DC-DC Converters](#) (SNVA489)
- [Automotive Cranking Simulator User's Guide](#) (SLVU984)

11.3 Receiving Notification of Documentation Updates

To receive notification of documentation updates, go to the device product folder on ti.com. In the upper right corner, click on *Alert me* to register for a weekly digest of any product information that has changed. For change details, review the revision history included in any revised document.

11.4 Support Resources

TI E2E™ support forums are an engineer's go-to source for fast, verified answers and design help — straight from the experts. Search existing answers or ask your own question to get the quick design help you need.

Linked content is provided "AS IS" by the respective contributors. They do not constitute TI specifications and do not necessarily reflect TI's views; see TI's [Terms of Use](#).

11.5 Trademarks

E2E is a trademark of Texas Instruments.
WEBENCH is a registered trademark of Texas Instruments.
All other trademarks are the property of their respective owners.

11.6 Electrostatic Discharge Caution



This integrated circuit can be damaged by ESD. Texas Instruments recommends that all integrated circuits be handled with appropriate precautions. Failure to observe proper handling and installation procedures can cause damage.

ESD damage can range from subtle performance degradation to complete device failure. Precision integrated circuits may be more susceptible to damage because very small parametric changes could cause the device not to meet its published specifications.

11.7 Glossary

[SLYZ022](#) — *TI Glossary*.

This glossary lists and explains terms, acronyms, and definitions.

12 Mechanical, Packaging, and Orderable Information

The following pages have mechanical, packaging, and orderable information. This information is the most current data available for the designated devices. This data is subject to change without notice and revision of this document. For browser-based versions of this data sheet, refer to the left-hand navigation.

12.1 Package Option Addendum

12.1.1 Packaging Information

Orderable Device	Status ⁽¹⁾	Package Type	Package Drawing	Pins	Package Qty	Eco Plan ⁽²⁾	Lead/Ball Finish ⁽³⁾	MSL Peak Temp ⁽⁴⁾	Op Temp (°C)	Device Marking ⁽⁵⁾⁽⁶⁾
PLM25183QNGURQ1	PREVIEW	WSON	NGU	8	TBD	TBD	Call TI	Call TI	-40 to 150	X25183Q

- (1) The marketing status values are defined as follows:
ACTIVE: Product device recommended for new designs.
LIFEBUY: TI has announced that the device will be discontinued, and a lifetime-buy period is in effect.
NRND: Not recommended for new designs. Device is in production to support existing customers, but TI does not recommend using this part in a new design.
PRE_PROD Unannounced device, not in production, not available for mass market, nor on the web, samples not available.
PREVIEW: Device has been announced but is not in production. Samples may or may not be available.
OBSOLETE: TI has discontinued the production of the device.
- (2) Eco Plan - The planned eco-friendly classification: Pb-Free (RoHS), Pb-Free (RoHS Exempt), or Green (RoHS & no Sb/Br) - please check <http://www.ti.com/productcontent> for the latest availability information and additional product content details.
TBD: The Pb-Free/Green conversion plan has not been defined.
Pb-Free (RoHS): TI's terms "Lead-Free" or "Pb-Free" mean semiconductor products that are compatible with the current RoHS requirements for all 6 substances, including the requirement that lead not exceed 0.1% by weight in homogeneous materials. Where designed to be soldered at high temperatures, TI Pb-Free products are suitable for use in specified lead-free processes.
Pb-Free (RoHS Exempt): This component has a RoHS exemption for either 1) lead-based flip-chip solder bumps used between the die and package, or 2) lead-based die adhesive used between the die and leadframe. The component is otherwise considered Pb-Free (RoHS compatible) as defined above.
Green (RoHS & no Sb/Br): TI defines "Green" to mean Pb-Free (RoHS compatible), and free of Bromine (Br) and Antimony (Sb) based flame retardants (Br or Sb do not exceed 0.1% by weight in homogeneous material)
- (3) Lead/Ball Finish - Orderable Devices may have multiple material finish options. Finish options are separated by a vertical ruled line. Lead/Ball Finish values may wrap to two lines if the finish value exceeds the maximum column width.
- (4) MSL, Peak Temp. -- The Moisture Sensitivity Level rating according to the JEDEC industry standard classifications, and peak solder temperature.
- (5) There may be additional marking, which relates to the logo, the lot trace code information, or the environmental category on the device
- (6) Multiple Device markings will be inside parentheses. Only one Device Marking contained in parentheses and separated by a "-" will appear on a device. If a line is indented then it is a continuation of the previous line and the two combined represent the entire Device Marking for that device.

Important Information and Disclaimer: The information provided on this page represents TI's knowledge and belief as of the date that it is provided. TI bases its knowledge and belief on information provided by third parties, and makes no representation or warranty as to the accuracy of such information. Efforts are underway to better integrate information from third parties. TI has taken and continues to take reasonable steps to provide representative and accurate information but may not have conducted destructive testing or chemical analysis on incoming materials and chemicals. TI and TI suppliers consider certain information to be proprietary, and thus CAS numbers and other limited information may not be available for release.

In no event shall TI's liability arising out of such information exceed the total purchase price of the TI part(s) at issue in this document sold by TI to Customer on an annual basis.



PACKAGE OUTLINE

NGU0008C

WSO_N - 0.8 mm max height

PLASTIC SMALL OUTLINE - NO LEAD

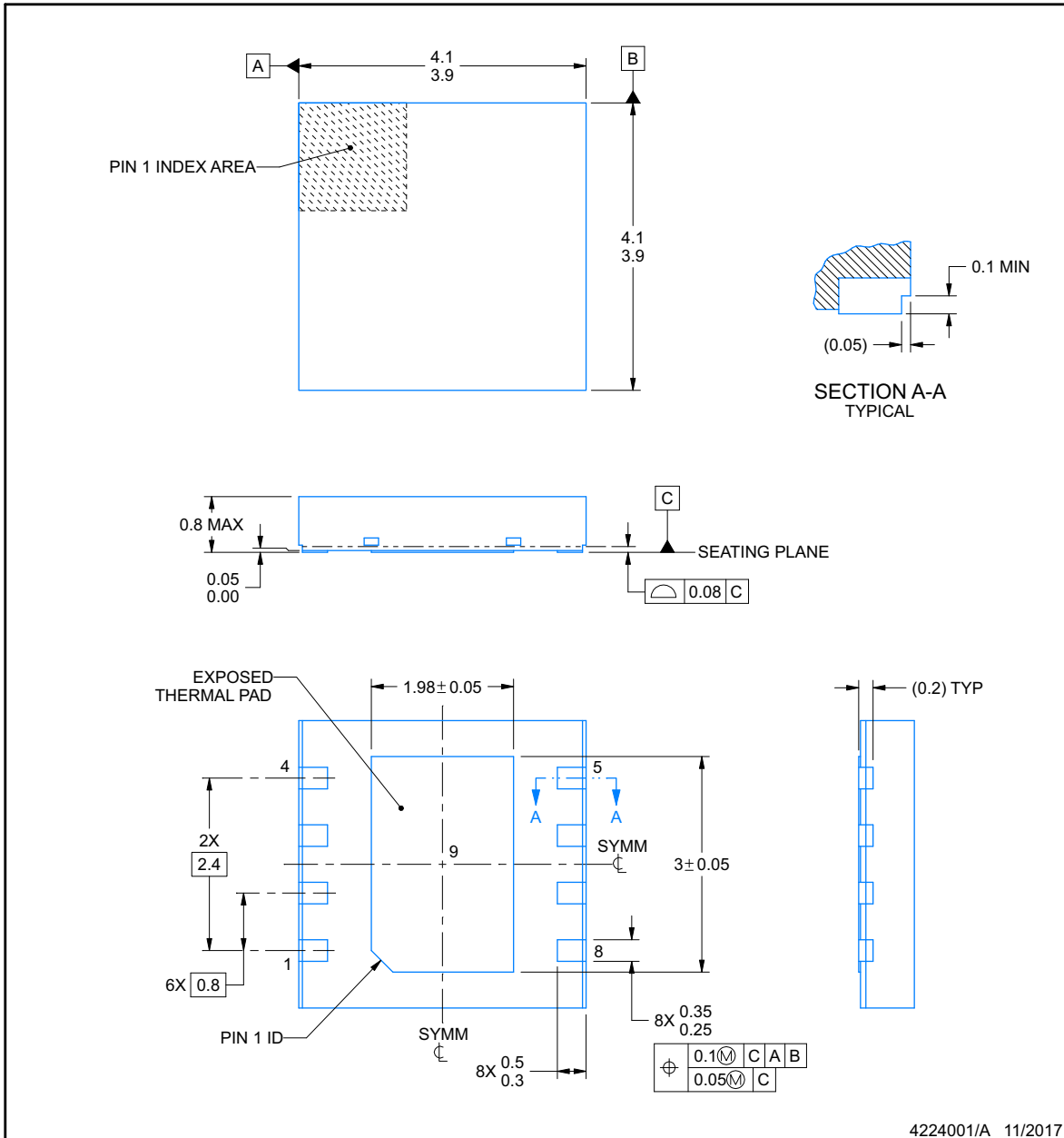

NOTES:

1. All linear dimensions are in millimeters. Any dimensions in parenthesis are for reference only. Dimensioning and tolerancing per ASME Y14.5M.
2. This drawing is subject to change without notice.
3. The package thermal pad must be soldered to the printed circuit board for thermal and mechanical performance.

EXAMPLE BOARD LAYOUT

NGU0008C

WSON - 0.8 mm max height

PLASTIC SMALL OUTLINE - NO LEAD

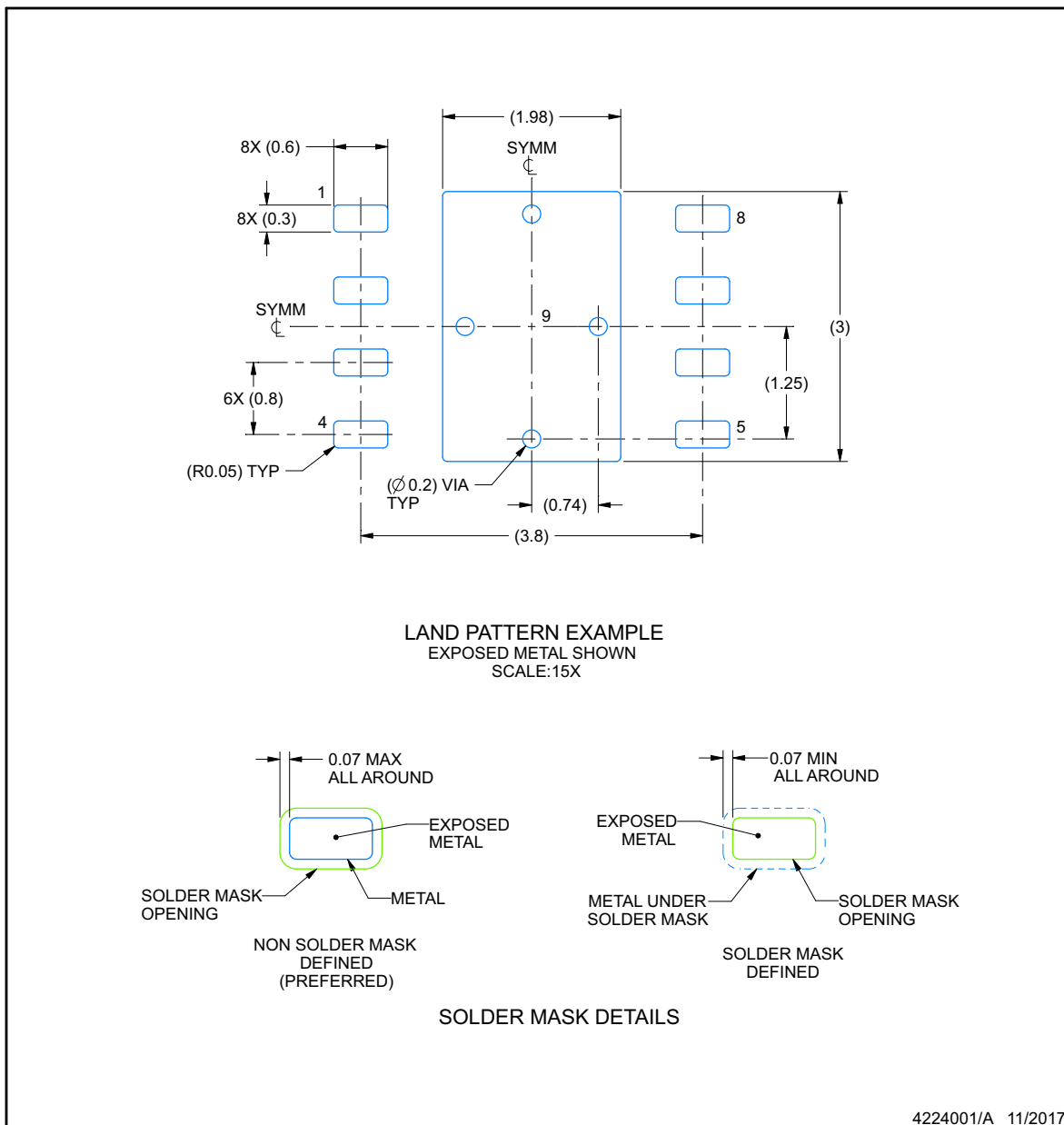

NOTES: (continued)

- This package is designed to be soldered to a thermal pad on the board. For more information, see Texas Instruments literature number SLUA271 (www.ti.com/lit/sluea271).
- Vias are optional depending on application, refer to device data sheet. If any vias are implemented, refer to their locations shown on this view. It is recommended that vias under paste be filled, plugged or tented.

ADVANCE INFORMATION

EXAMPLE STENCIL DESIGN

NGU0008C

WSON - 0.8 mm max height

PLASTIC SMALL OUTLINE - NO LEAD

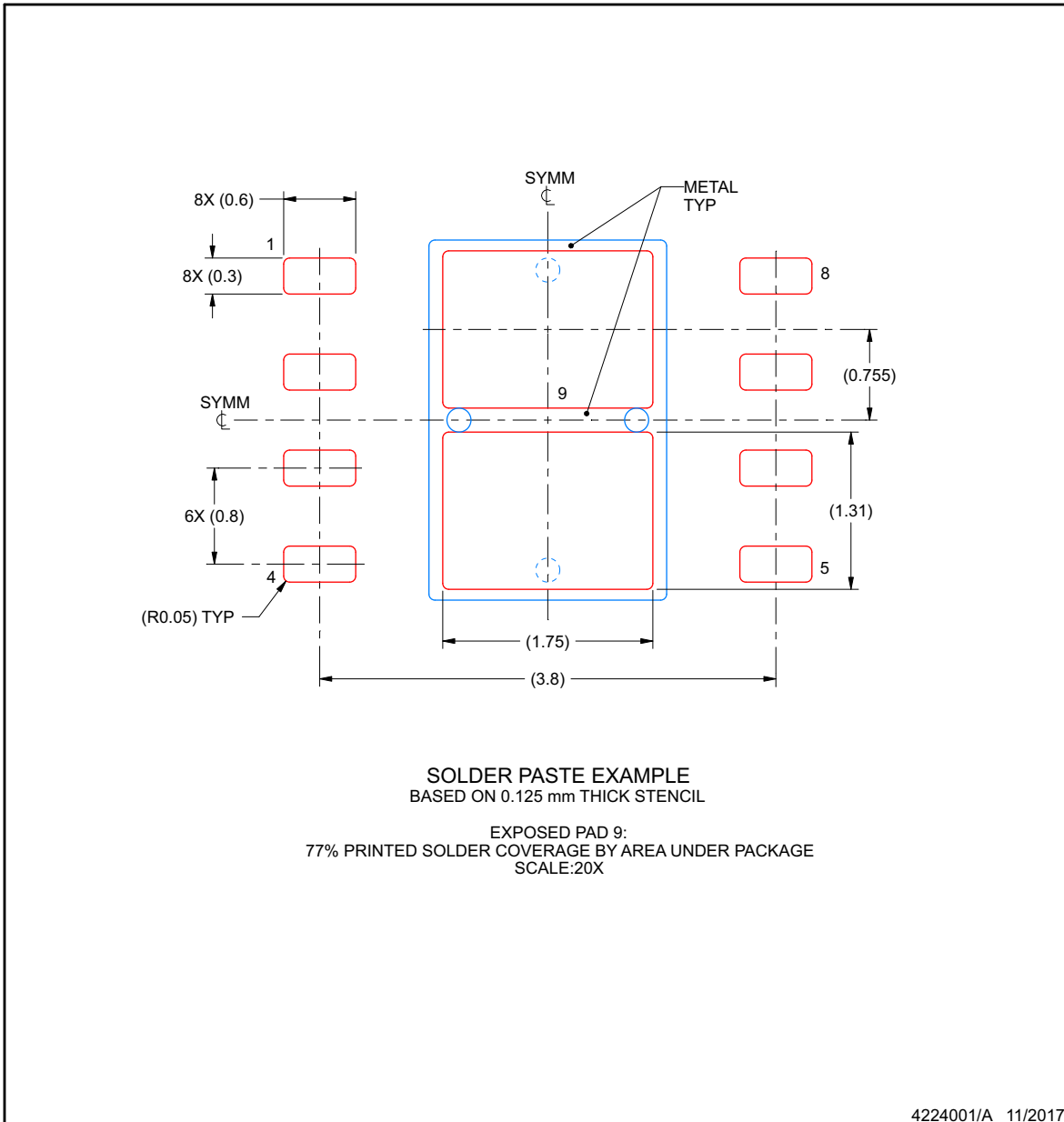

NOTES: (continued)

- 6. Laser cutting apertures with trapezoidal walls and rounded corners may offer better paste release. IPC-7525 may have alternate design recommendations.

ADVANCE INFORMATION

NGU0008B

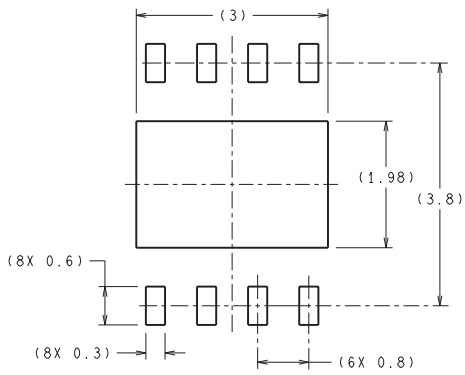

RECOMMENDED LAND PATTERN

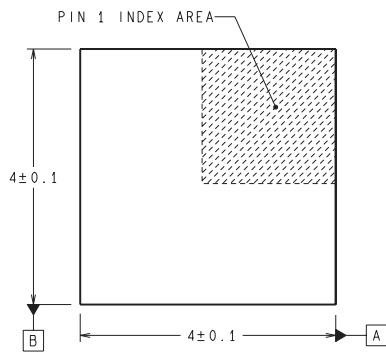

DIMENSIONS ARE IN MILLIMETERS
DIMENSIONS IN () FOR REFERENCE ONLY

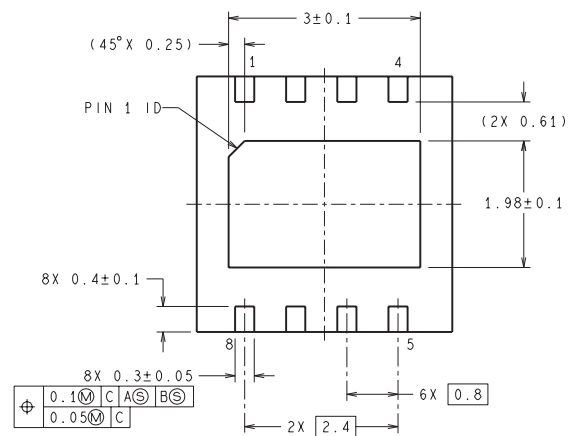
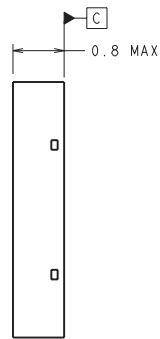

SDC08B (Rev A)

IMPORTANT NOTICE AND DISCLAIMER

TI PROVIDES TECHNICAL AND RELIABILITY DATA (INCLUDING DATASHEETS), DESIGN RESOURCES (INCLUDING REFERENCE DESIGNS), APPLICATION OR OTHER DESIGN ADVICE, WEB TOOLS, SAFETY INFORMATION, AND OTHER RESOURCES "AS IS" AND WITH ALL FAULTS, AND DISCLAIMS ALL WARRANTIES, EXPRESS AND IMPLIED, INCLUDING WITHOUT LIMITATION ANY IMPLIED WARRANTIES OF MERCHANTABILITY, FITNESS FOR A PARTICULAR PURPOSE OR NON-INFRINGEMENT OF THIRD PARTY INTELLECTUAL PROPERTY RIGHTS.

These resources are intended for skilled developers designing with TI products. You are solely responsible for (1) selecting the appropriate TI products for your application, (2) designing, validating and testing your application, and (3) ensuring your application meets applicable standards, and any other safety, security, or other requirements. These resources are subject to change without notice. TI grants you permission to use these resources only for development of an application that uses the TI products described in the resource. Other reproduction and display of these resources is prohibited. No license is granted to any other TI intellectual property right or to any third party intellectual property right. TI disclaims responsibility for, and you will fully indemnify TI and its representatives against, any claims, damages, costs, losses, and liabilities arising out of your use of these resources.

TI's products are provided subject to TI's Terms of Sale (www.ti.com/legal/termsofsale.html) or other applicable terms available either on ti.com or provided in conjunction with such TI products. TI's provision of these resources does not expand or otherwise alter TI's applicable warranties or warranty disclaimers for TI products.

Mailing Address: Texas Instruments, Post Office Box 655303, Dallas, Texas 75265
Copyright © 2020, Texas Instruments Incorporated