

Ultra High Dynamic Range Broadband Amplifier

ZFL-272VH+

50Ω 0.03 to 2.7 GHz

Features

- High IP3, 47dBm typ. at 1GHz
- Gain, 17dB typ. at 1GHz
- High Pout, P1dB 30dBm typ. at 1GHz
- Internally regulated DC and reverse voltage protected

Applications

- Base station infrastructure
- LTE

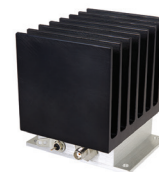

CASE STYLE: AW2740

Connectors	Model
SMA	ZFL-272VH+

+RoHS Compliant

The +Suffix identifies RoHS Compliance. See our web site for RoHS Compliance methodologies and qualifications

Electrical Specifications at 25°C, V_{DD}=15V unless noted

Parameter	Condition (MHz)	V _{DD} =15V			Units
		Min.	Typ.	Max.	
Frequency range		0.03		2.7	GHz
Gain	30	—	17.4	—	dB
	500	—	17.8	—	
	1000	—	16.9	—	
	2000	13.1	14.5	16.1	
	2700	—	12.6	—	
Input return loss	30	—	11.6	—	dB
	500	—	24.7	—	
	1000	—	23.2	—	
	2000	—	21.2	—	
	2700	—	13.2	—	
Output return loss	30	—	14.1	—	dB
	500	—	15.5	—	
	1000	—	17.3	—	
	2000	—	19.0	—	
	2700	—	10.4	—	
Reverse isolation	2000	—	23	—	dB
Output power @ 1dB compression	30	—	29.1	—	dBm
	500	—	29.5	—	
	1000	—	29.5	—	
	2000	—	27.7	—	
	2700	—	25.0	—	
Output IP3 ¹	30	—	49.8	—	dBm
	500	—	49.3	—	
	1000	—	47.2	—	
	2000	—	43.0	—	
	2700	—	42.0	—	
Noise figure	30	—	4.2	—	dB
	500	—	3.1	—	
	1000	—	3.4	—	
	2000	—	4.4	—	
	2700	—	5.2	—	
Device operating voltage		15	15	—	V
Device operating current		—	350	416	mA

1. Tested at Pout=16 dBm / tone



Maximum Ratings

Parameter	Ratings
Operating Temperature	-40°C to 60°C
Storage Temperature	-55°C to 100°C
Input RF Power (no damage)	+24 dBm (5 minutes max.) 19 dBm (continuous)
DC Voltage	+17V

Permanent damage may occur if any of these limits are exceeded.

Outline Drawing

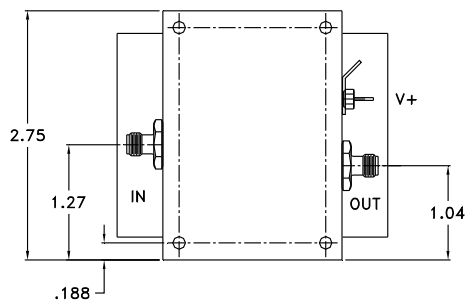
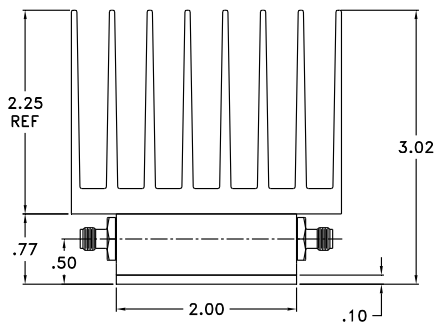
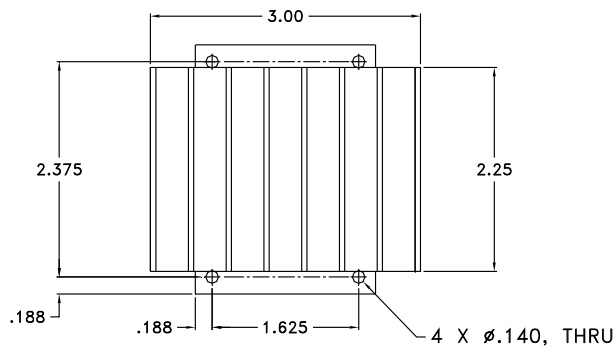

Weight: 360 grams

FREQUENCY (MHz)	GAIN (dB)	DIRECIVITY (dB)	VSWR (:1)		NOISE FIGURE (dB)	POUT at 1 dB COMPR. (dBm)	IP3 (dBm)
			IN	OUT			
30	17.32	6.87	1.70	1.49	4.30	29.12	49.02
100	18.12	5.15	1.18	1.51	3.08	29.80	50.11
500	17.72	5.51	1.08	1.45	3.16	30.29	49.02
1000	16.78	6.47	1.13	1.31	3.51	30.08	46.68
1200	16.40	6.81	1.14	1.25	3.65	29.89	46.04
1400	15.92	7.33	1.13	1.21	3.87	29.40	45.04
1600	15.53	7.72	1.09	1.18	4.02	28.77	44.16
1800	15.08	8.23	1.05	1.18	4.17	28.38	43.16
2000	14.57	8.91	1.07	1.22	4.42	27.59	41.95
2200	13.83	10.07	1.23	1.27	4.92	26.74	40.73
2400	13.50	10.46	1.31	1.39	4.89	25.87	38.99
2700	12.47	12.24	1.53	1.81	5.42	24.72	37.39

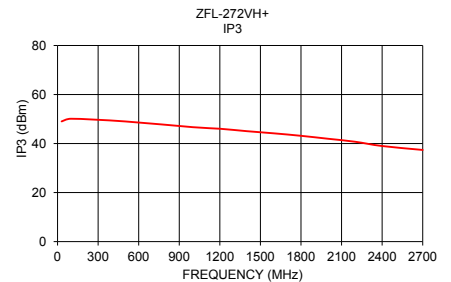
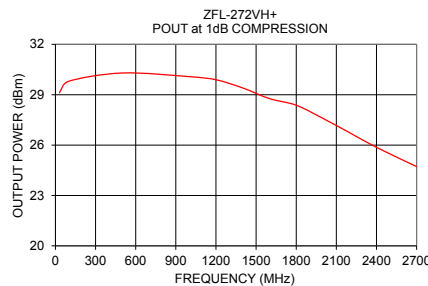
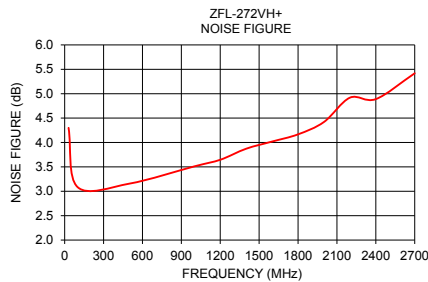
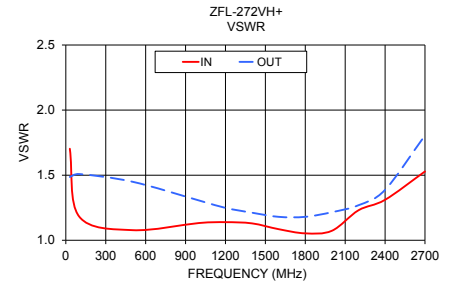
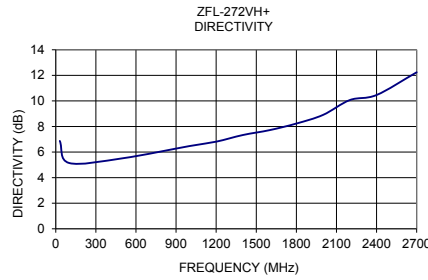
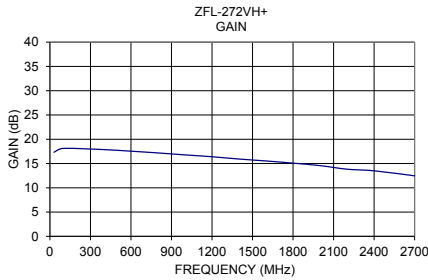

Additional Notes

- A. Performance and quality attributes and conditions not expressly stated in this specification document are intended to be excluded and do not form a part of this specification document.
- B. Electrical specifications and performance data contained in this specification document are based on Mini-Circuit's applicable established test performance criteria and measurement instructions.
- C. The parts covered by this specification document are subject to Mini-Circuits standard limited warranty and terms and conditions (collectively, "Standard Terms"); Purchasers of this part are entitled to the rights and benefits contained therein. For a full statement of the Standard Terms and the exclusive rights and remedies thereunder, please visit Mini-Circuits' website at www.minicircuits.com/MCLStore/terms.jsp