

Description

The AL5816Q is a 5-terminal adjustable constant current linear LED controller offering excellent temperature stability and current capability. The AL5816Q can work with a wide input voltage range from 4.5V to 60V. With its low 200mV current sense FB voltage, it controls the regulation of LED current with minimum power dissipation compared with traditional linear LED drivers. This makes it ideal for medium to high current LEDs.

The device has an internal output drive up to 15mA, which enables it to drive external Bipolar transistors or MOSFETs. It also provides the capability to drive longer LED chains with low drop out voltage and multiple LED channels.

The AL5816Q has LED current adjusted and controlled by a sense resistor connected across FB pin and GND. The voltage across this resistor is controlled to a precise 0.2V thus controlling the current.

The AL5816Q can be dimmed by PWM signal through PWM pin, it can run at frequencies higher than 200Hz.

The AL5816Q is available in SOT25 package, and is Automotive-Compliant, qualified to AEC-Q100 Grade 1, supporting PPAP documentation.

Features

- Qualified to AEC-Q100 Grade 1
- Wide Input Voltage Range from 4.5V to 60V
- Low Reference Voltage ($V_{FB} = 0.2V$)
- 5% Reference Voltage Tolerance
- Up to 15mA Driver Capability for Bipolar Transistor
- PWM Dimming Capable
- Input Under Voltage Lock-out
- Over Temperature Shutdown
- **Totally Lead-Free & Fully RoHS Compliant (Notes 1 & 2)**
- **Halogen and Antimony Free. "Green" Device (Note 3)**
- **PPAP Capable (Note 4)**

- Notes:
1. No purposely added lead. Fully EU Directive 2002/95/EC (RoHS), 2011/65/EU (RoHS 2) & 2015/863/EU (RoHS 3) compliant.
 2. See <https://www.diodes.com/quality/lead-free/> for more information about Diodes Incorporated's definitions of Halogen- and Antimony-free, "Green" and Lead-free.
 3. Halogen- and Antimony-free "Green" products are defined as those which contain <900ppm bromine, <900ppm chlorine (<1500ppm total Br + Cl) and <1000ppm antimony compounds.
 4. Automotive products are AEC-Q100 qualified and are PPAP capable. Refer to <https://www.diodes.com/quality/>.

Pin Assignments

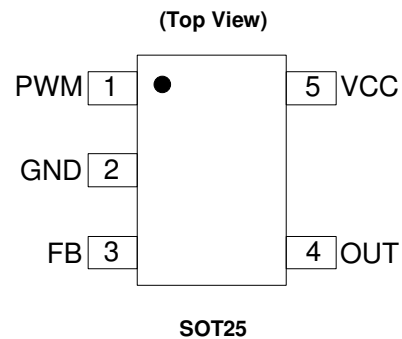

Applications

- Automotive Rear Lamps
- Automotive Interior Lamps
- Automotive Instrumentation Illumination
- Automotive Position Lamps
- Automotive License Plate Illumination

Typical Applications Circuit

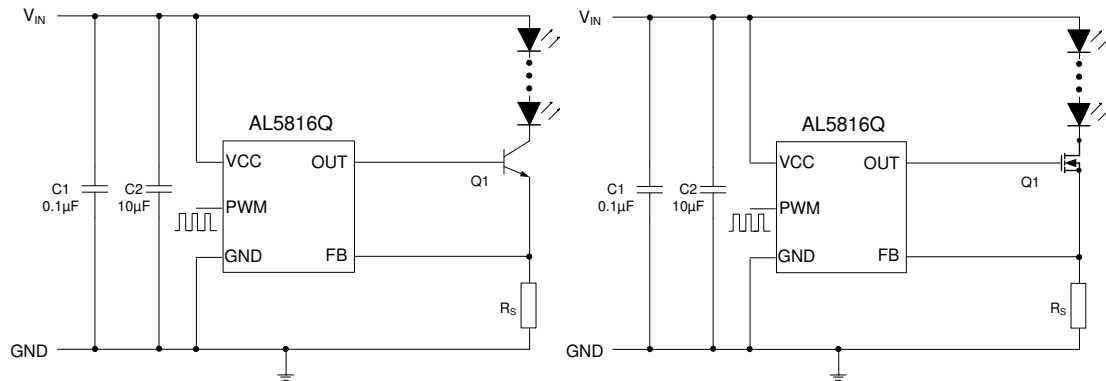

Pin Descriptions

Pin Number	Pin Name	Function
1	PWM	PWM Signal for High Frequency Dimming of the LED
2	GND	Ground
3	FB	Feedback Input, Regulates to 200mV Nominally
4	OUT	Driving Output to External Transistors
5	VCC	Input Supply Power

Functional Block Diagram

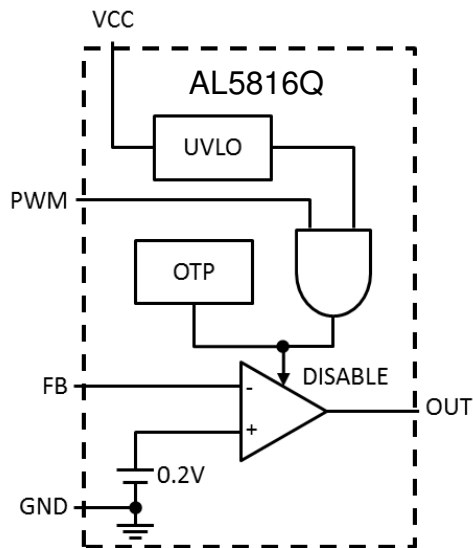

Absolute Maximum Ratings (Note 5)

Symbol	Parameter	Rating	Unit
V _{CC}	Supply Voltage Relative to GND	-0.3 to +65	V
I _{VCC}	IC Supply Current	18	mA
V _{OUT} , V _{FB}	OUT, FB Relative to GND	-0.3 to +6	V
V _{PWM}	PWM Pin Relative to GND	-0.3 to V _{CC}	V
T _J	Operating Junction Temperature	-40 to +150	°C
T _{ST}	Storage Temperature	-55 to +150	°C

Note: 5. Stresses greater than the Absolute Maximum Ratings specified above may cause permanent damage to the device. These are stress ratings only, and functional operation of the device at conditions between maximum recommended operating conditions and absolute maximum ratings is not implied. Device reliability may be affected by exposure to absolute maximum rating conditions for extended periods of time.

ESD Ratings

Symbol	Parameter	Rating	Unit
V _{ESD}	Human-Body Model (HBM), Per AEC-Q100-002 (Note 6)	±2000	V
	Charged-Device Model (CDM)	±1000	

Note: 6. AEC-Q100-002 indicates that HBM stressing shall be accordance with the ANSI/ESDA/JEDEC JS-001 specification.

Recommended Operating Conditions

Symbol	Parameter	Min	Max	Unit
V _{CC}	Supply Voltage Range Relative to GND Pin	4.5	60	V
V _{OUT}	OUT Voltage Range (Note 7)	0	3	V
I _{OUT}	OUT Pin Current (Note 7)	0	15	mA
T _A	Operating Ambient Temperature	-40	+125	°C
V _{IH}	High-Level Input Voltage on PWM	2.7	60	V
V _{IL}	Low-Level Input Voltage on PWM	0	2.3	V

Note: 7. The maximum source current and drive voltage out of the OUT pin is limited by an internal clamp as well as maximum recommended junction temperature not exceeding +150°C.
 OUT voltages greater than 3V are supported but at reduced output currents.
 As V_{CC} reduces below 6V the maximum output voltage supporting output currents above 10mA also reduces; V_{CC} - V_{OUT} ≥ 3V.

Thermal Information (Note 8)

Symbol	Parameter	Rating	Unit
θ _{JA}	Junction-To-Ambient Thermal Resistance	160	°C/W
θ _{JC}	Junction-To-Case (Top) Thermal Resistance	35	°C/W

Note: 8. Device mounted on 1"x1" FR-4 MRP substrate PC board, 2oz cooper, with minimum recommended pad layout. No thermal via and no ground plane.

Electrical Characteristics ($V_{CC} = 12V$, $T_A = -40^{\circ}C$ to $+125^{\circ}C$. Typical values are at $T_A = +25^{\circ}C$, unless otherwise specified.)

Symbol	Parameter	Condition	Min	Typ	Max	Unit	
POWER SUPPLY							
V_{UVLO}	Under-Voltage Lockout Voltage	V_{IN} Rising (1V/ms)	—	4.2	4.4	V	
		V_{IN} Falling (1V/ms)	3.6	3.85	—		
I_{CC}	Supply Current	$V_{CC} = 4.5V$ to $60V$, $I_{OUT} = 10mA$	—	10.25	11	mA	
I_Q	Quiescent Current into V_{CC}	$V_{CC} = 4.5V$ to $60V$, $I_{OUT} = 0mA$	—	0.25	1	mA	
V_{PWM_TH}	PWM Pin Threshold Voltage	$V_{CC} = 4.5V$ to $60V$, V_{PWM} Falling	2.37	2.5	2.63	V	
$V_{PWM_TH_HYS}$	PWM Pin Threshold Voltage Hysteresis	—	—	0.1	—	V	
I_{PWM}	PWM Pin Internal Pull Up Current	$V_{PWM} = 5V$, $V_{CC} = 4.5V$ to $60V$	-20	-15	-11	μA	
FEEDBACK LOOP							
V_{FB}	Feedback Voltage	$V_{CC} = 4.5V$ to $60V$	0.19	0.2	0.21	V	
V_{REF_LINE}	Reference Voltage Line Regulation	$V_{CC} = 4.5V$ to $19V$	—	0.2	2	mV	
I_{FB}	FB Input Bias Current	$V_{FB} = 0.2V$	-200	-125	-70	nA	
OUTPUT DRIVER ERROR AMPLIFIER							
$I_{OUTSOURCE}$	Maximum Source Current	$V_{OUT} = 1V$, $V_{CC} = 4.5V$ to $60V$	$T_A = +25^{\circ}C$	—	—	-15	mA
			$-40^{\circ}C \leq T_A \leq +125^{\circ}C$	—	—	-13	mA
		$V_{OUT} = 2V$, $V_{CC} = 4.5V$ to $60V$	$T_A = +25^{\circ}C$	—	—	-11	mA
			$-40^{\circ}C \leq T_A \leq +125^{\circ}C$	—	—	-9	mA
		$V_{OUT} = 3V$, $V_{CC} = 6.0V$ to $60V$	$T_A = +25^{\circ}C$	—	—	-15	mA
			$-40^{\circ}C \leq T_A \leq +125^{\circ}C$	—	—	-13	mA
$I_{OUTSINK}$	Maximum Sink Current	$V_{CC} = 12V$, $V_{PWM} = 0V$ $V_{OUT} = 4V$, $V_{FB} = 250mV$	1	—	—	mA	
G_m	Trans-conductance of Error Amplifier (Sourcing)	$\Delta V_{FB} = 5mV$	—	5	—	A/V	
f_{BW}	Bandwidth (From FB to OUT)	No Loading (Note 9)	—	50	—	kHz	
V_{OUT_MAX}	Maximum Output Voltage	$V_{CC} \geq 6V$, $I_{OUT} = -1mA$	4	—	—	V	
V_{OUT_MIN}	Minimum Output Voltage	$V_{CC} = 12V$, $V_{PWM} = 0V$ $I_{OUT} = 0.1mA$, $V_{FB} = 250mV$	—	—	300	mV	
t_{ON}	Turn On Delay Time	PWM Active High (Note 9)	—	2	—	μs	
t_{OFF}	Turn Off Delay Time	PWM Active Low (Note 9)	—	2	—	μs	
THERMAL SHUTDOWN							
T_{SHDN}	Thermal Shutdown	(Note 9)	—	+160	—	$^{\circ}C$	
T_{HYS}	Thermal Shutdown Hysteresis	(Note 9)	—	+30	—	$^{\circ}C$	

Note: 9. Not tested in production.

Typical Performance Characteristics ($V_{CC} = 12V$, $T_A = +25^\circ C$, unless otherwise specified.)

Supply Current vs. Temperature

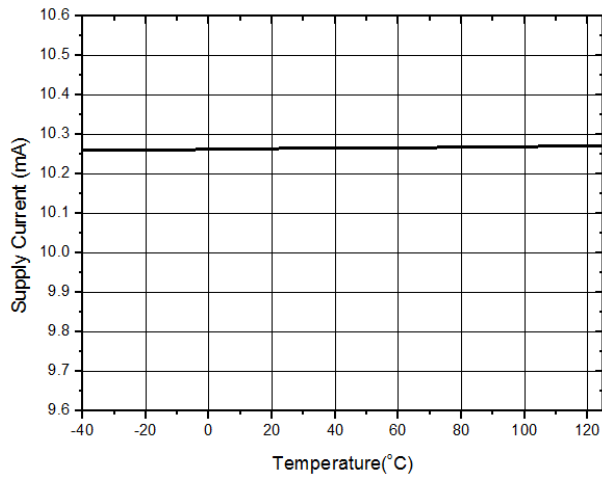

Quiescent Current vs. Temperature

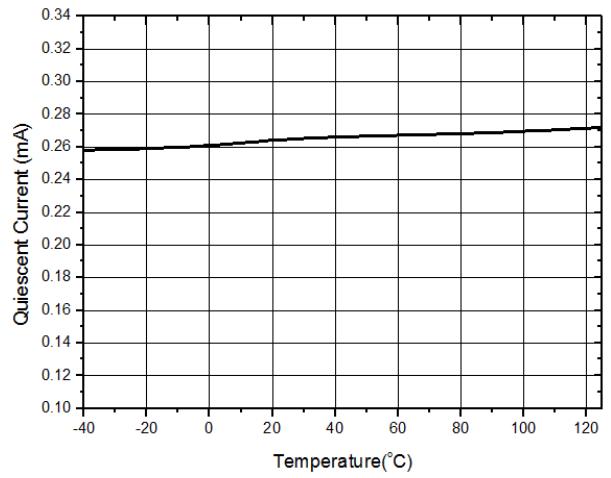

V_{UVLO} vs. Temperature

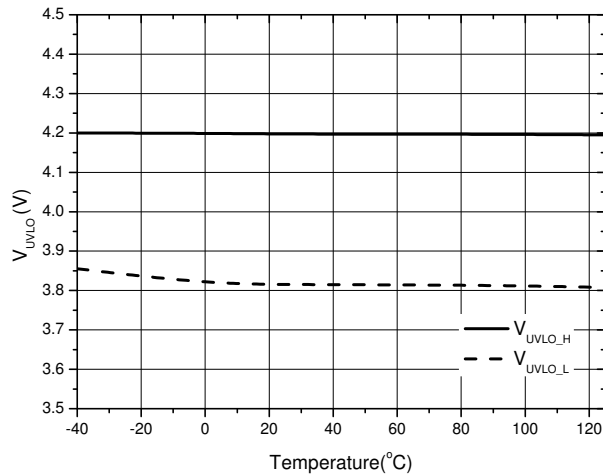

Feedback Voltage vs. Temperature

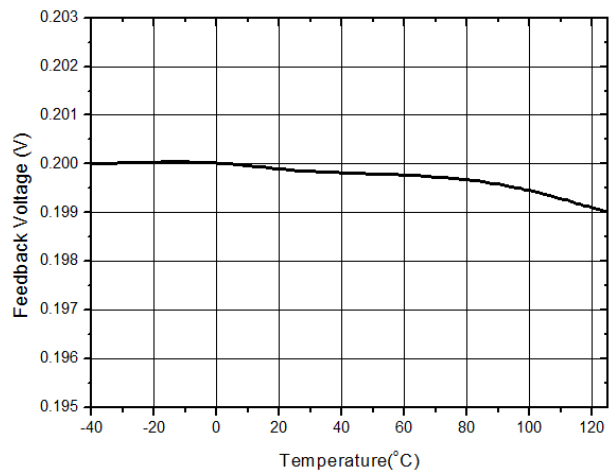

Out Source Current (I_{OUT}) vs. Temperature

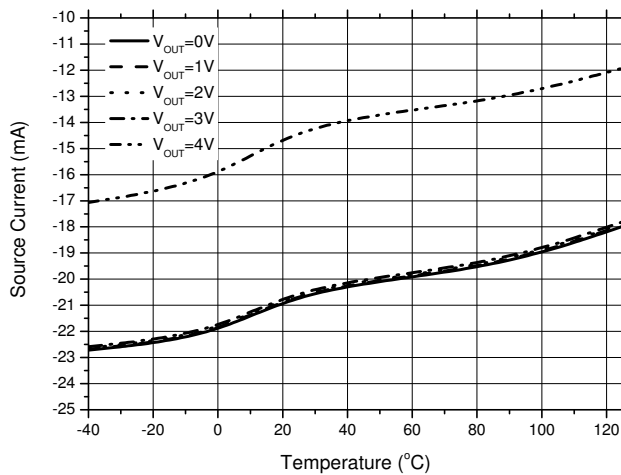

Application Information

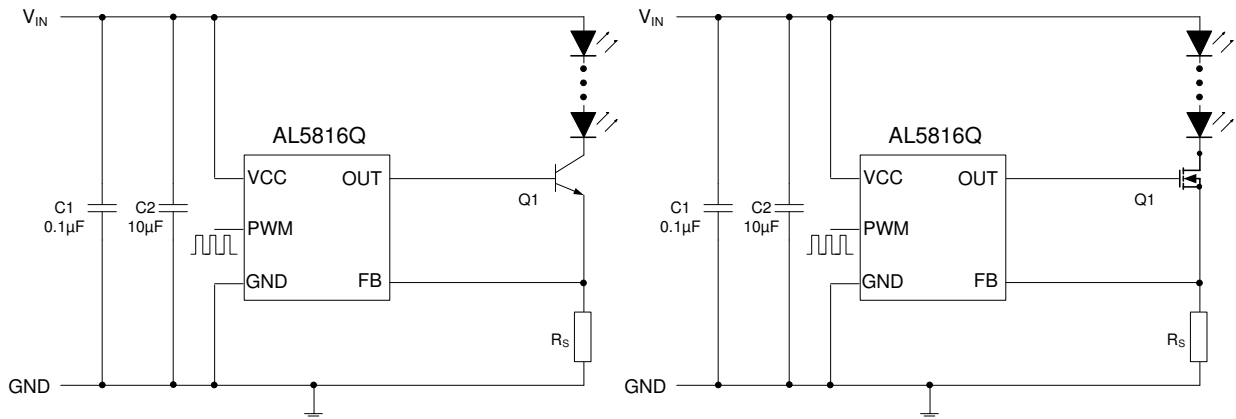

Figure 1. Typical Application Circuit Using BJT and MOSFET

Output Drive

Figure 1 shows the typical output drive configuration. The feedback loop regulates the current through the external LED. The voltage across the external sense resistor (R_S) is fed into the FB pin for sensing. When the voltage exceeds the internal reference of 0.2V, the OUT goes lower, decreasing the drive to the external transistor.

The output current can be set as following:

$$I_{LED} = \frac{V_{FB}}{R_S} \quad (1)$$

Where I_{LED} is the desired LED current, V_{FB} is the reference voltage (0.2V) and R_S is the sense resistor.

The power in the resistor is calculated as:

$$P = V_{SENSE} * I_{LED}$$

Where $V_{SENSE} = 0.2V$ and LED current is the desired LED string current. For a typical case of 250mA LED the power dissipation would be:

$$P = 0.2V * 0.25A = 0.05W$$

A standard 1/4W resistor would work in this case. Similarly, the external transistor's power dissipation also must be considered to prevent thermal damage to the transistor, which can further damage the LED controller IC.

Multiple LED Strings in Parallel

The AL5816Q can drive more than one channel of LED strings. As shown in Figure 2, the sense voltage of two channels' (or more) output current can be implemented by connecting the voltage of one sense resistor to the FB pin.

By utilizing the same type transistors, sense resistors and series base resistor, the current will match.

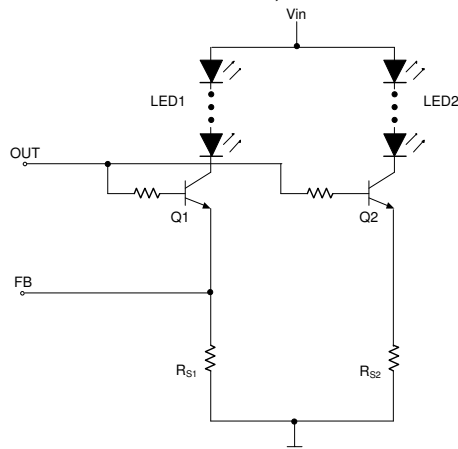

Figure 2. Two LED Strings in Parallel

Application Information (Cont.)

The output current can be set as following:

$$I_{LED1} = I_{LED2} = \dots = V_{FB} / R_{S1}$$

Where I_{LED} is the desired LED current, V_{FB} is 0.2V, and R_{S1} is the sense resistor. To keep I_{LED} the same, transistors Q1 and Q2 should be matched, and R_{S1} and R_{S2} should be matched.

PWM Dimming

The AL5816Q can be dimmed by PWM signal, it can run at frequencies greater than 200Hz.

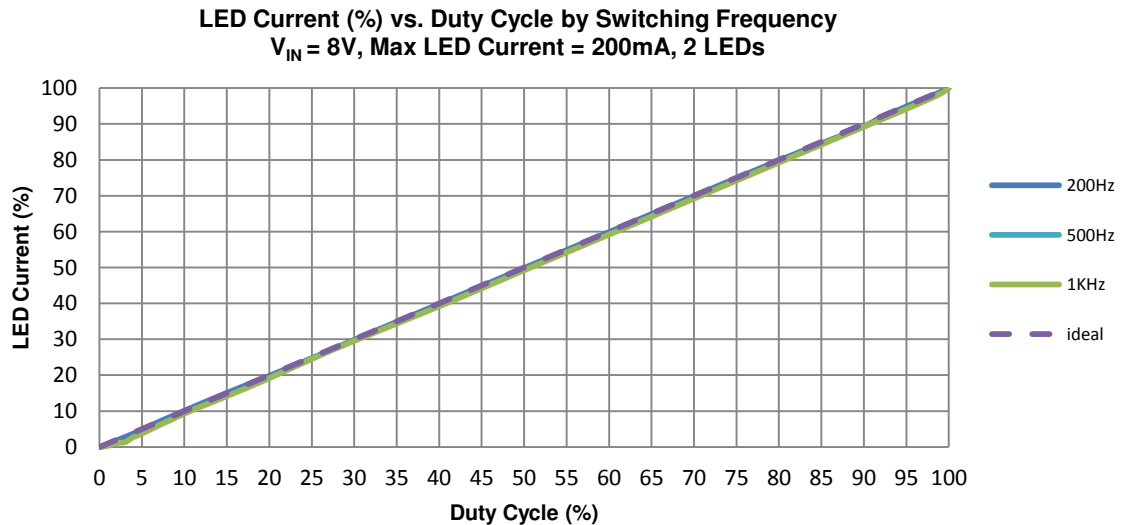

Figure 3. PWM Dimming Curve of AL5816Q

Thermal Protection

The AL5816Q has internal Over Temperature Protection (OTP). When the junction temperature is over +160°C, the IC will shut down. A power cycle off and on or the junction temperature dropping by +30°C will make the IC turn back on.

Power Consideration

The power rating of the transistor (either BJT or NMOS) used in the typical application circuit is important. A correctly mounted transistor used in a typical application can dissipate a maximum of 2W. To calculate power dissipation, first calculate the voltage drop across the transistor as follows:

$$V_{DS} = V_{CC} - V_{LED} - 0.2V$$

Then calculate the power dissipation requirement:

$$P = V_{DS} \cdot I_{LED}$$

If power dissipation is higher than the transistor package and layout can dissipate then a higher power dissipation transistor must be selected and/or use a better PCB layout.

Feedback Loop

The device has internal compensation and therefore there's no need to have any components in the feedback loop.

Ordering Information

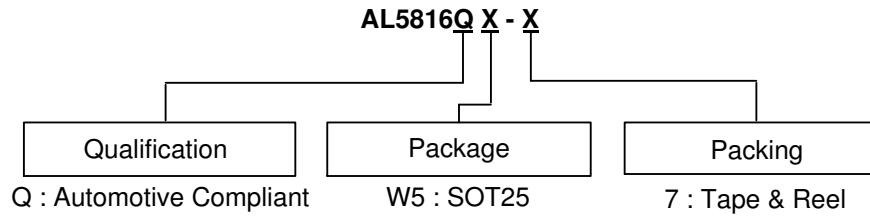

Part Number	Package Code (Note 10)	Package	Tape and Reel	
			Quantity	Part Number Suffix
AL5816QW5-7	W5	SOT25	3000/Tape & Reel	-7

Note: 10. For packaging details, go to our website at <https://www.diodes.com/design/support/packaging/diodes-packaging/>.

Marking Information

(Top View)

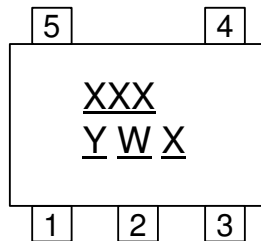

- XXX : Identification Code
- Y : Year 0 to 9
- W : Week : A to Z : 1 to 26 week;
a to z : 27 to 52 week; z represents 52 and 53 week
- X : Internal Code

Part Number	Package Type	Identification Code
AL5816QW5-7	SOT25	BJQ

Package Outline Dimensions

Please see <http://www.diodes.com/package-outlines.html> for the latest version.

SOT25

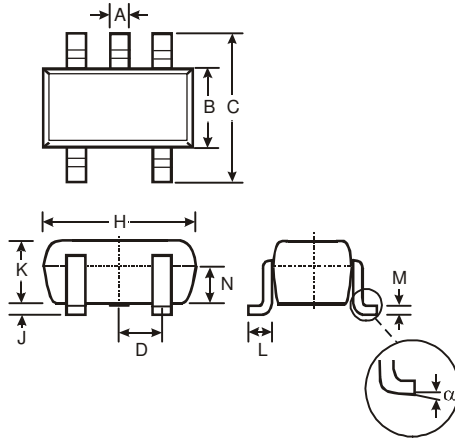

SOT25			
Dim	Min	Max	Typ
A	0.35	0.50	0.38
B	1.50	1.70	1.60
C	2.70	3.00	2.80
D	-	-	0.95
H	2.90	3.10	3.00
J	0.013	0.10	0.05
K	1.00	1.30	1.10
L	0.35	0.55	0.40
M	0.10	0.20	0.15
N	0.70	0.80	0.75
α	0°	8°	-
All Dimensions in mm			

Suggested Pad Layout

Please see <http://www.diodes.com/package-outlines.html> for the latest version.

SOT25

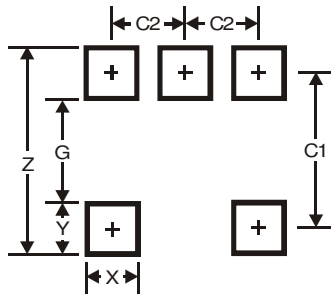

Dimensions	Value
Z	3.20
G	1.60
X	0.55
Y	0.80
C1	2.40
C2	0.95

IMPORTANT NOTICE

DIODES INCORPORATED MAKES NO WARRANTY OF ANY KIND, EXPRESS OR IMPLIED, WITH REGARDS TO THIS DOCUMENT, INCLUDING, BUT NOT LIMITED TO, THE IMPLIED WARRANTIES OF MERCHANTABILITY AND FITNESS FOR A PARTICULAR PURPOSE (AND THEIR EQUIVALENTS UNDER THE LAWS OF ANY JURISDICTION).

Diodes Incorporated and its subsidiaries reserve the right to make modifications, enhancements, improvements, corrections or other changes without further notice to this document and any product described herein. Diodes Incorporated does not assume any liability arising out of the application or use of this document or any product described herein; neither does Diodes Incorporated convey any license under its patent or trademark rights, nor the rights of others. Any Customer or user of this document or products described herein in such applications shall assume all risks of such use and will agree to hold Diodes Incorporated and all the companies whose products are represented on Diodes Incorporated website, harmless against all damages.

Diodes Incorporated does not warrant or accept any liability whatsoever in respect of any products purchased through unauthorized sales channel. Should Customers purchase or use Diodes Incorporated products for any unintended or unauthorized application, Customers shall indemnify and hold Diodes Incorporated and its representatives harmless against all claims, damages, expenses, and attorney fees arising out of, directly or indirectly, any claim of personal injury or death associated with such unintended or unauthorized application.

Products described herein may be covered by one or more United States, international or foreign patents pending. Product names and markings noted herein may also be covered by one or more United States, international or foreign trademarks.

This document is written in English but may be translated into multiple languages for reference. Only the English version of this document is the final and determinative format released by Diodes Incorporated.

LIFE SUPPORT

Diodes Incorporated products are specifically not authorized for use as critical components in life support devices or systems without the express written approval of the Chief Executive Officer of Diodes Incorporated. As used herein:

A. Life support devices or systems are devices or systems which:

1. are intended to implant into the body, or
2. support or sustain life and whose failure to perform when properly used in accordance with instructions for use provided in the labeling can be reasonably expected to result in significant injury to the user.

B. A critical component is any component in a life support device or system whose failure to perform can be reasonably expected to cause the failure of the life support device or to affect its safety or effectiveness.

Customers represent that they have all necessary expertise in the safety and regulatory ramifications of their life support devices or systems, and acknowledge and agree that they are solely responsible for all legal, regulatory and safety-related requirements concerning their products and any use of Diodes Incorporated products in such safety-critical, life support devices or systems, notwithstanding any devices- or systems-related information or support that may be provided by Diodes Incorporated. Further, Customers must fully indemnify Diodes Incorporated and its representatives against any damages arising out of the use of Diodes Incorporated products in such safety-critical, life support devices or systems.

Copyright © 2018, Diodes Incorporated

www.diodes.com