

cSPIN™: microstepping motor controller with motion engine and SPI

Datasheet – production data

Features

- Operating voltage: 7.5 V - 85 V
- Dual full-bridge gate driver for N-channel MOSFETs
- Fully programmable gate driving
- Embedded Miller clamp function
- Programmable speed profile
- Up to 1/16 microstepping
- Advanced current control with auto-adaptive decay mode
- Integrated voltage regulators
- SPI interface
- Low quiescent standby currents
- Programmable non-dissipative overcurrent protection
- Overtemperature protection

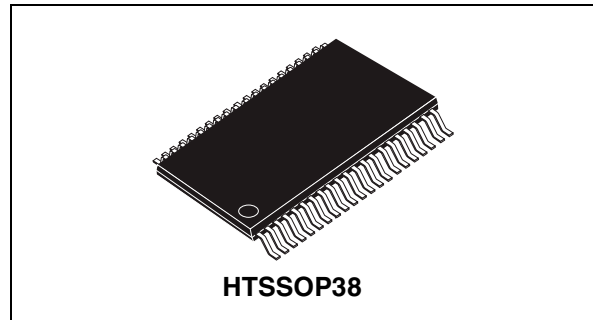

non-dissipative overcurrent protection. Thanks to a new current control, a 1/16 microstepping is achieved through an adaptive decay mode which outperforms traditional implementations. The digital control core can generate user defined motion profiles with acceleration, deceleration, speed or target position easily programmed through a dedicated register set. All application commands and data registers, including those used to set analog values (i.e. current protection trip point, deadtime, PWM frequency, etc.) are sent through a standard 5-Mbit/s SPI. A very rich set of protections (thermal, low bus voltage, overcurrent and motor stall) make the L6482 “bullet proof”, as required by the most demanding motor control applications.

Applications

- Bipolar stepper motor

Description

The L6482, realized in analog mixed signal technology, is an advanced fully integrated solution suitable for driving two-phase bipolar stepper motors with microstepping.

It integrates a dual full-bridge gate driver for N-channel MOSFET power stages with embedded

Table 1. Device summary

Order code	Package	Packaging
L6482H	HTSSOP38	Tube
L6482HTR	HTSSOP38	Tape and reel

Contents

- 1 Block diagram 8**
- 2 Electrical data 9**
 - 2.1 Absolute maximum ratings 9
 - 2.2 Recommended operating conditions 10
 - 2.3 Thermal data 10
- 3 Electrical characteristics 11**
- 4 Pin connection 16**
 - 4.1 Pin list 16
- 5 Typical applications 18**
- 6 Functional description 19**
 - 6.1 Device power-up 19
 - 6.2 Logic I/O 19
 - 6.3 Charge pump 19
 - 6.4 Microstepping 20
 - 6.4.1 Automatic Full-step and Boost modes 21
 - 6.5 Absolute position counter 22
 - 6.6 Programmable speed profiles 22
 - 6.6.1 Infinite acceleration/deceleration mode 22
 - 6.7 Motor control commands 23
 - 6.7.1 Constant speed commands 23
 - 6.7.2 Positioning commands 23
 - 6.7.3 Motion commands 24
 - 6.7.4 Stop commands 25
 - 6.7.5 Step-clock mode 25
 - 6.7.6 GoUntil and ReleaseSW commands 25
 - 6.8 Internal oscillator and oscillator driver 26
 - 6.8.1 Internal oscillator 26
 - 6.8.2 External clock source 26

6.9	Overcurrent detection	27
6.10	Undervoltage lockout (UVLO)	28
6.11	VS undervoltage lockout (UVLO_ADC)	29
6.12	Thermal warning and thermal shutdown	29
6.13	Reset and standby	30
6.14	External switch (SW pin)	30
6.15	Programmable gate drivers	31
6.16	Deadtime and blanking time	32
6.17	Integrated analog-to-digital converter	32
6.18	Supply management and internal voltage regulators	33
6.19	BUSY/SYNC pin	34
6.20	FLAG pin	34
7	Phase current control	35
7.1	Predictive current control	35
7.2	Auto-adjusted decay mode	36
7.3	Auto-adjusted fast decay during the falling steps	38
7.4	Torque regulation (output current amplitude regulation)	39
8	Serial interface	41
9	Programming manual	43
9.1	Register and flag description	43
9.1.1	ABS_POS	44
9.1.2	EL_POS	44
9.1.3	MARK	45
9.1.4	SPEED	45
9.1.5	ACC	45
9.1.6	DEC	46
9.1.7	MAX_SPEED	46
9.1.8	MIN_SPEED	46
9.1.9	FS_SPD	47
9.1.10	TVAL_HOLD, TVAL_RUN, TVAL_ACC and TVAL_DEC	47
9.1.11	T_FAST	48
9.1.12	TON_MIN	48

9.1.13	TOFF_MIN	49
9.1.14	ADC_OUT	50
9.1.15	OCD_TH	50
9.1.16	STEP_MODE	51
9.1.17	ALARM_EN	52
9.1.18	GATECFG1	53
9.1.19	GATECFG2	54
9.1.20	CONFIG	55
9.1.21	STATUS	58
9.2	Application commands	60
9.2.1	Command management	61
9.2.2	Nop	62
9.2.3	SetParam (PARAM, VALUE)	62
9.2.4	GetParam (PARAM)	62
9.2.5	Run (DIR, SPD)	63
9.2.6	StepClock (DIR)	63
9.2.7	Move (DIR, N_STEP)	64
9.2.8	GoTo (ABS_POS)	64
9.2.9	GoTo_DIR (DIR, ABS_POS)	65
9.2.10	GoUntil (ACT, DIR, SPD)	65
9.2.11	ReleaseSW (ACT, DIR)	66
9.2.12	GoHome	66
9.2.13	GoMark	66
9.2.14	ResetPos	67
9.2.15	ResetDevice	67
9.2.16	SoftStop	67
9.2.17	HardStop	68
9.2.18	SoftHiZ	68
9.2.19	HardHiZ	68
9.2.20	GetStatus	69
10	Package mechanical data	70
11	Revision history	72

List of tables

Table 1.	Device summary	1
Table 2.	Absolute maximum ratings	9
Table 3.	Recommended operating conditions	10
Table 4.	Thermal data	10
Table 5.	Electrical characteristics	11
Table 6.	Pin description	16
Table 7.	Typical application values	18
Table 8.	CL values according to external oscillator frequency	26
Table 9.	UVLO thresholds	29
Table 10.	Thermal protection summarizing table	30
Table 11.	Register map	43
Table 12.	EL_POS register	44
Table 13.	MIN_SPEED register	46
Table 14.	FS_SPD register	47
Table 15.	Torque regulation by TVAL_HOLD, TVAL_ACC, TVAL_DEC and TVAL_RUN registers	48
Table 16.	FS_SPD register	48
Table 17.	Maximum fast decay times	48
Table 18.	Minimum on-time	49
Table 19.	Minimum off-time	49
Table 20.	ADC_OUT value and torque regulation feature	50
Table 21.	Overcurrent detection threshold	50
Table 22.	STEP_MODE register	51
Table 23.	Step mode selection	51
Table 24.	SYNC output frequency	52
Table 25.	SYNC signal source	52
Table 26.	ALARM_EN register	52
Table 27.	GATECFG1 register	53
Table 28.	IGATE parameter	53
Table 29.	TCC parameter	54
Table 30.	TBOOST parameter	54
Table 31.	GATECFG2 register (voltage mode)	54
Table 32.	TDT parameter	55
Table 33.	TBLANK parameters	55
Table 34.	CONFIG register	55
Table 35.	Oscillator management	56
Table 36.	External switch HardStop interrupt mode	56
Table 37.	Overcurrent event	57
Table 38.	Programmable V _{CC} regulator output voltage	57
Table 39.	Programmable UVLO thresholds	57
Table 40.	External torque regulation enable	57
Table 41.	Switching period	57
Table 42.	Motor supply voltage compensation enable	58
Table 43.	STATUS register	58
Table 44.	STATUS register TH_STATUS bits	59
Table 45.	STATUS register DIR bit	59
Table 46.	STATUS register MOT_STATE bits	59
Table 47.	Application commands	60
Table 48.	Nop command structure	62

Table 49.	SetParam command structure	62
Table 50.	GetParam command structure	62
Table 51.	Run command structure	63
Table 52.	StepClock command structure	63
Table 53.	Move command structure	64
Table 54.	GoTo command structure	64
Table 55.	GoTo_DIR command structure	65
Table 56.	GoUntil command structure	65
Table 57.	ReleaseSW command structure	66
Table 58.	GoHome command structure	66
Table 59.	GoMark command structure	66
Table 60.	ResetPos command structure	67
Table 61.	ResetDevice command structure	67
Table 62.	SoftStop command structure	67
Table 63.	HardStop command structure	68
Table 64.	SoftHiZ command structure	68
Table 65.	HardHiZ command structure	68
Table 66.	GetStatus command structure	69
Table 67.	HTSSOP38 mechanical data	70
Table 68.	Document revision history	72

List of figures

Figure 1.	Block diagram	8
Figure 2.	Pin connection (top view)	16
Figure 3.	Typical application schematic	18
Figure 4.	Charge pump circuitry	20
Figure 5.	Normal mode and microstepping (16 microsteps)	20
Figure 6.	Automatic Full-step switching in Normal mode	21
Figure 7.	Automatic Full-step switching in Boost mode	22
Figure 8.	Speed profile in infinite acceleration/deceleration mode	23
Figure 9.	Constant speed command examples	23
Figure 10.	Positioning command examples	24
Figure 11.	Motion command examples	24
Figure 12.	OSCIN and OSCOUT pin configuration	27
Figure 13.	Overcurrent detection-principle scheme	28
Figure 14.	External switch connection	31
Figure 15.	Gate driving currents	32
Figure 16.	Device supply pin management	33
Figure 17.	Predictive current control	35
Figure 18.	Non-predictive current control	36
Figure 19.	Adaptive decay - fast decay tuning	37
Figure 20.	Adaptive decay - switch from normal to slow+fast decay mode and vice versa	38
Figure 21.	Fast decay tuning during the falling steps	39
Figure 22.	Current sensing and reference voltage generation	40
Figure 23.	SPI timings diagram	41
Figure 24.	Daisy chain configuration	42
Figure 25.	Command with 3-byte argument	61
Figure 26.	Command with 3-byte response	61
Figure 27.	Command response aborted	61
Figure 28.	HTSSOP38 package dimensions	70
Figure 29.	HTSSOP38 footprint	71

1 Block diagram

Figure 1. Block diagram

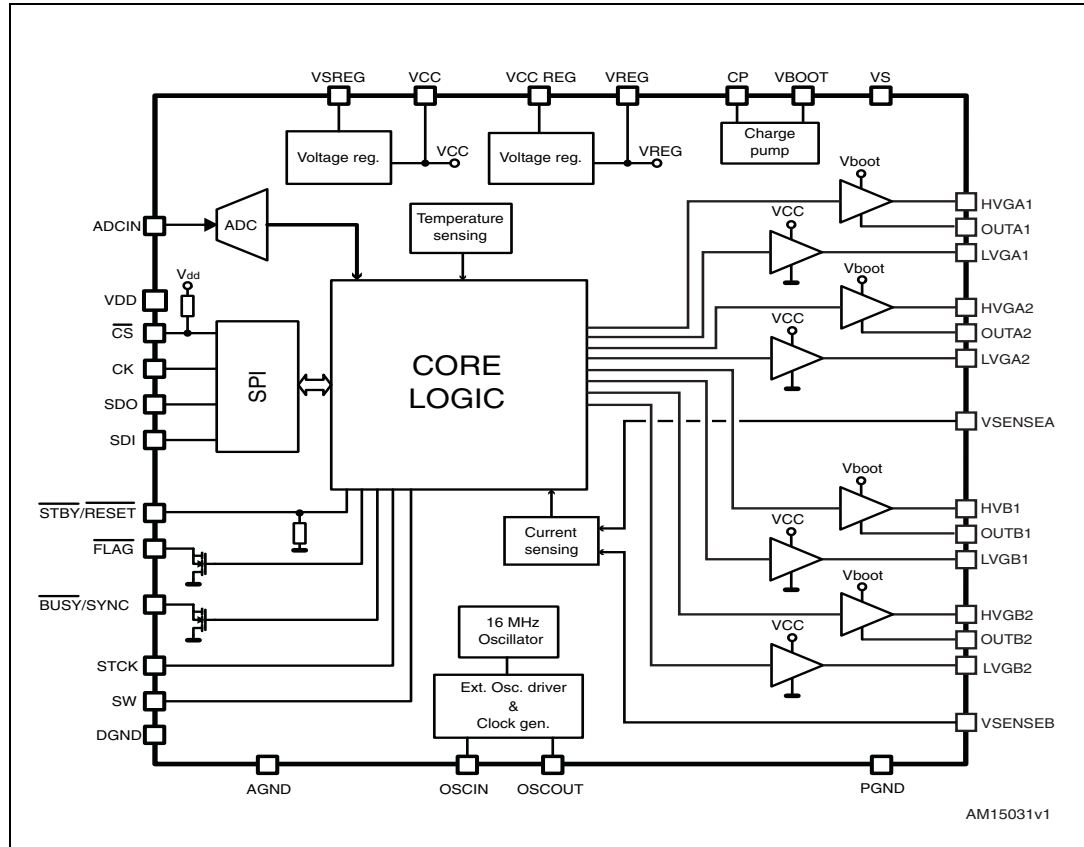

2 Electrical data

2.1 Absolute maximum ratings

Table 2. Absolute maximum ratings

Symbol	Parameter	Test condition	Value	Unit
V_{DD}	Logic interface supply voltage		5.5	V
V_{REG}	Logic supply voltage		3.6	
V_S	Motor supply voltage		95	V
V_{CC}	Low-side gate driver supply voltage		18	V
V_{BOOT}	Boot voltage		100	V
ΔV_{BOOT}	High-side gate driver supply voltage		0 to 20	V
V_{SREG}	Internal V_{CC} regulator supply voltage		95	V
V_{CCREG}	Internal V_{REG} regulator supply voltage		18	V
V_{OUT1A} V_{OUT2A} V_{OUT1B} V_{OUT2B}	Full-bridge output voltage	DC	-5 to V_{BOOT}	V
		AC	-15 to V_{BOOT}	
SR_{out}	Full-bridge output slew rate (10% - 90%)		10	V/ns
V_{HVG1A} V_{HVG2A} V_{HVG1B} V_{HVG2B}	High-side output driver voltage		V_{OUT} to V_{BOOT}	V
ΔV_{HVG1A} ΔV_{HVG2A} ΔV_{HVG1B} ΔV_{HVG2B}	High-side output driver to respective bridge output voltage ($V_{HVG} - V_{OUT}$)		15	V
V_{LVG1A} V_{LVG2A} V_{LVG1B} V_{LVG2B}	Low-side output driver voltage		$V_{CC} + 0.3$	V
$I_{GATE-CLAMP}$	High-side gate voltage clamp current capability		100	mA
V_{ADCIN}	Integrated ADC input voltage range (ADCIN pin)		-0.3 to 3.6	V
V_{out_diff}	Differential voltage between V_{BOOT} , V_S , $OUT1A$, $OUT2A$, $PGND$ and V_{BOOT} , V_S , $OUT1B$, $OUT2B$, $PGND$ pins		100	V

Table 2. Absolute maximum ratings (continued)

Symbol	Parameter	Test condition	Value	Unit
V_{in}	Logic inputs voltage range		-0.3 to 5.5	V
T_s T_{OP}	Storage and operating junction temperature		-40 to 150	°C
P_{tot}	Total power dissipation ($T_{amb} = 25$ °C)	(1)	4	W

1. HTSSOP38 mounted on a four-layer FR4 PCB with a dissipating copper surface of about 30 cm².

2.2 Recommended operating conditions

Table 3. Recommended operating conditions

Symbol	Parameter	Test condition	Min.	Typ.	Max.	Unit
V_{DD}	Logic interface supply voltage	3.3 V logic outputs		3.3		V
		5 V logic outputs		5		
V_{REG}	Logic supply voltage			3.3		V
V_S	Motor supply voltage		V_{SREG}		85	V
V_{SREG}	Internal V_{CC} voltage regulator	V_{CC} voltage internally generated	$V_{CC} + 3$		V_s	V
V_{CC}	Gate driver supply voltage	V_{CC} voltage imposed by external source ($V_{SREG} = V_{CC}$)	7.5		15	V
V_{CCREG}	Internal V_{REG} voltage regulator supply voltage	V_{REG} voltage internally generated	6.3		V_{CC}	V
V_{ADC}	Integrated ADC input voltage (ADCIN pin)		0		V_{REG}	V

2.3 Thermal data

Table 4. Thermal data

Symbol	Parameter	Package	Typ.	Unit
R_{thj-a}	Thermal resistance junction-to-ambient	HTSSOP38 ⁽¹⁾	31	°C/W

1. HTSSOP38 mounted on a four-layer FR4 PCB with a dissipating copper surface of about 30 cm².

3 Electrical characteristics

$V_S = 48\text{ V}$; $V_{CC} = 7.5\text{ V}$; $T_j = 25\text{ °C}$, unless otherwise specified.

Table 5. Electrical characteristics

Symbol	Parameter	Test condition	Min.	Typ.	Max.	Unit
General						
V_{CCthOn}	V_{CC} UVLO turn-on threshold	UVLO_VAL set high ⁽¹⁾	9.9	10.4	10.9	V
		UVLO_VAL set low ⁽¹⁾	6.5	6.9	7.3	V
$V_{CCthOff}$	V_{CC} UVLO turn-off threshold	UVLO_VAL set high ⁽¹⁾	9.5	10	10.5	V
		UVLO_VAL set low ⁽¹⁾	5.9	6.3	6.7	V
$\Delta V_{BOOTthOn}$	$V_{BOOT} - V_S$ UVLO turn-on threshold	UVLO_VAL set high ⁽¹⁾	8.6	9.2	9.8	V
		UVLO_VAL set low ⁽¹⁾	5.7	6	6.3	V
$\Delta V_{BOOTthOff}$	$V_{BOOT} - V_S$ UVLO turn-off threshold	UVLO_VAL set high ⁽¹⁾	8.2	8.8	9.5	V
		UVLO_VAL set low ⁽¹⁾	5.3	5.5	5.8	V
$V_{REGthOn}$	V_{REG} turn-on threshold	(1)	2.8	3	3.18	V
$V_{REGthOff}$	V_{REG} turn-off threshold	(1)	2.2	2.4	2.5	V
$I_{VSREGqu}$	Undervoltage V_{SREG} quiescent supply current	$V_{CCREG} = V_{REG} < 2.2\text{ V}$		40		μA
I_{VSREGq}	Quiescent V_{SREG} supply current	$V_{CCREG} = V_{REG} < 3.3\text{ V}$, internal oscillator selected ⁽¹⁾		3.8		mA
I_{VSREGq}	Quiescent V_{SREG} supply current	$V_{CCREG} = V_{REG} = 15\text{ V}$		6.5		mA
Thermal protection						
$T_{j(WRN)Set}$	Thermal warning temperature			135		$^{\circ}\text{C}$
$T_{j(WRN)Rec}$	Thermal warning recovery temperature			125		$^{\circ}\text{C}$
$T_{j(OFF)Set}$	Thermal bridge shutdown temperature			155		$^{\circ}\text{C}$
$T_{j(OFF)Rec}$	Thermal bridge shutdown recovery temperature			145		$^{\circ}\text{C}$
$T_{j(SD)Set}$	Thermal device shutdown temperature			170		$^{\circ}\text{C}$
$T_{j(SD)Rec}$	Thermal device shutdown recovery temperature			130		$^{\circ}\text{C}$
Charge pump						
V_{pump}	Voltage swing for charge pump oscillator			V_{CC}		V
$f_{pump,min}$	Minimum charge pump oscillator frequency ⁽²⁾			660		kHz
$f_{pump,max}$	Maximum charge pump oscillator frequency ⁽²⁾			800		kHz
R_{pumpHS}	Charge pump high-side $R_{DS(on)}$ resistance			10		Ω

Table 5. Electrical characteristics (continued)

Symbol	Parameter	Test condition	Min.	Typ.	Max.	Unit
R_{pumpLS}	Charge pump low-side $R_{DS(ON)}$ resistance			10		Ω
I_{boot}	Average boot current			2.6		mA
Gate driver outputs						
$I_{GATE,Sink}$	Programmable high-side and low-side gate sink current	$V_S = 38\text{ V}$ $V_{HVGX} - V_{OUTX} > 3\text{ V}$ $V_{LVGX} > 3\text{ V}$	2.4	4	5.6	mA
			5.4	8	10.6	
			11.3	16	20.7	
			17.3	24	30.7	
			23.2	32	40.8	
			50.2	64	77.8	
			81	96	113	
$I_{GATE,Source}$	Programmable high-side and low-side gate source current	$V_S = 38\text{ V}$ $V_{BOOTX} - V_{HVGX} > 3.5\text{ V}$ $V_{CC} - V_{LVGX} > 3.5\text{ V}$	2.8	4	5.2	mA
			5.8	8	10.2	
			12	16	20	
			18	24	30	
			24	32	40	
			51	64	77	
			82	96	112	
I_{OB}	High-side and low-side turn-off overboost gate current		85	103	117	mA
$R_{CLAMP(LS)}$	Low-side gate driver Miller clamp resistance			6.5	10	Ω
$R_{CLAMP(HS)}$	High-side gate driver Miller clamp resistance			3	10	Ω
$V_{GATE-CLAMP}$	High-side gate voltage clamp	$I_{GATE-CLAMP} = 100\text{ mA}$		16.7		v
t_{cc}	Programmable constant gate current time ⁽²⁾	TCC='00000'		125		ns
		TCC= 11111		3750		
t_{OB}	Programmable. Turn-off overboost; gate current time ⁽²⁾	TBOOST='001', internal oscillator		62.5		ns
		TBOOST='111'		1000		
I_{DSS}	Leakage current	OUT = V_S			100	μA
		OUT = GND	-100			μA
t_r	Rise time	$I_{GATE} = 96\text{ mA}$ $V_{CC} = 15\text{ V}$ $C_{GATE} = 15\text{ nF}$		2.5		μs
t_f	Fall time	$I_{GATE} = 96\text{ mA}$ $V_{CC} = 15\text{ V}$ $C_{GATE} = 15\text{ nF}$		2.5		μs

Table 5. Electrical characteristics (continued)

Symbol	Parameter	Test condition	Min.	Typ.	Max.	Unit
SRgate	Gate driver output slew rate	$I_{GATE} = 96 \text{ mA}$ $V_{CC} = 15 \text{ V}$ $C_{GATE} = 15 \text{ nF}$		6		V/ μs
Deadtime and blanking						
t_{DT}	Programmable deadtime ⁽²⁾	TDT= '00000'		125		ns
		TDT= '11111'		4000		
t_{blank}	Programmable blanking time ⁽²⁾	TBLANK= '000'		125		ns
		TBLANK= '111'		1000		
Logic						
V_{IL}	Low level logic input voltage				0.8	V
V_{IH}	High level logic input voltage		2			V
I_{IH}	High level logic input current	$V_{IN} = 5 \text{ V}$, $V_{DDIO} = 5 \text{ V}$			1	μA
I_{IL}	Low level logic input current	$V_{IN} = 0 \text{ V}$, $V_{DDIO} = 5 \text{ V}$	-1			μA
V_{OL}	Low level logic output voltage ⁽³⁾	$V_{DD} = 3.3 \text{ V}$, $I_{OL} = 4 \text{ mA}$			0.3	V
		$V_{DD} = 5 \text{ V}$, $I_{OL} = 4 \text{ mA}$			0.3	
V_{OH}	High level logic output voltage	$V_{DD} = 3.3 \text{ V}$, $I_{OH} = 4 \text{ mA}$	2.4			V
		$V_{DD} = 5 \text{ V}$, $I_{OH} = 4 \text{ mA}$	4.7			
R_{PUCS}	CS pull-up resistor			430		k Ω
R_{PDRST}	STBY/RESET pull-down resistor			450		
R_{PUSW}	SW pull-up resistor			80		
$t_{high,STCK}$	Step-clock input high time			300		ns
$t_{low,STCK}$	Step-clock input low time			300		ns
Internal oscillator and external oscillator driver						
$f_{osc,int}$	Internal oscillator frequency	$T_j = 25 \text{ }^\circ\text{C}$,	-5%	16	+5%	MHz
$f_{osc,ext}$	Programmable external oscillator frequency		8		32	MHz
$V_{OSCOOUTH}$	OSCOOUT clock source high level voltage	Internal oscillator	2.4			V
$V_{OSCOUHL}$	OSCOOUT clock source low level voltage	Internal oscillator			0.3	V
$t_{rOSCOUHL}$ $t_{fOSCOUHL}$	OSCOOUT clock source rise and fall time	Internal oscillator			10	ns
t_{high}	OSCOOUT clock source high time	Internal oscillator		62.5		ns
t_{extosc}	Internal to external oscillator switching delay			3		ms
t_{intosc}	External to internal oscillator switching delay				100	μs

Table 5. Electrical characteristics (continued)

Symbol	Parameter	Test condition	Min.	Typ.	Max.	Unit
SPI						
$f_{CK,MAX}$	Maximum SPI clock frequency ⁽⁴⁾		5			MHz
t_{rCK} t_{fCK}	SPI clock rise and fall time ⁽⁴⁾				1	μ s
t_{hCK} t_{lCK}	SPI clock high and low time ⁽⁴⁾		90			ns
t_{setCS}	Chip select setup time ⁽⁴⁾		30			ns
t_{holCS}	Chip select hold time ⁽⁴⁾		30			ns
t_{disCS}	Deselect time ⁽⁴⁾		625			ns
t_{setSDI}	Data input setup time ⁽⁴⁾		20			ns
t_{holSDI}	Data input hold time ⁽⁴⁾		30			ns
t_{enSDO}	Data output enable time ⁽⁴⁾				95	ns
t_{disSDO}	Data output disable time ⁽⁴⁾				95	ns
t_{vSDO}	Data output valid time ⁽⁴⁾				35	ns
t_{holSDO}	Data output hold time ⁽⁴⁾		0			ns
Current control						
$V_{REF,max}$	Maximum reference voltage			1000		mV
$V_{REF,min}$	Minimum reference voltage			7.8		mV
Overcurrent protection						
V_{OCD}	Programmable overcurrent detection voltage V_{DS} threshold	OCD_TH = '11111'	800	1000	1100	mV
		OCD_TH = '00000'	27	31	35	mV
		OCD_TH = '01001'	270	312.5	344	mV
		OCD_TH = '10011'	500	625	688	mV
$t_{OCD,Comp}$	OCD comparator delay		100	200	ns	
$t_{OCD,Flag}$	OCD to flag signal delay time		230	530	ns	
$t_{OCD,SD}$	OCD to shutdown delay time	OCD_TH = '11111' OCD event to 90% of gate voltage		400	630	ns
Standby						
I_{STBY}	Standby mode supply current (VSREG pin)	$V_{CC} = V_{CCREG} = 7.5\text{ V}$ $V_{SREG} = 48\text{ V}$		42		μ A
		$V_{CC} = V_{CCREG} = 7.5\text{ V}$ $V_{SREG} = 18\text{ V}$		37.5		
$I_{STBY,vreg}$	Standby mode supply current (VREG pin)			6		μ A
$t_{STBY,min}$	Minimum standby time			0.5		ms
$t_{logicwu}$	Logic power-on and wake-up time			500		μ s

Table 5. Electrical characteristics (continued)

Symbol	Parameter	Test condition	Min.	Typ.	Max.	Unit
t_{cpwu}	Charge pump power-on and wake-up time	Power bridges disabled, $C_p = 10 \text{ nF}$, $C_{boot} = 220 \text{ nF}$, $V_{CC} = 15 \text{ V}$		1		ms
Internal voltage regulators						
V_{CCOUT}	Internal V_{CC} voltage regulator output voltage	Low (default), $I_{CC} = 10 \text{ mA}$	7.3	7.5		V
		High, $I_{CC} = 10 \text{ mA}$	4	15		
$V_{CCREG, drop}$	V_{SREG} to V_{CC} dropout voltage	$I_{CC} = 50 \text{ mA}$			3	V
P_{CC}	Internal V_{CC} voltage regulator power dissipation				2.5	W
V_{REGOUT}	Internal V_{REG} voltage regulator output voltage	$I_{REG} = 10 \text{ mA}$	3.13 5	3.3		V
$V_{SREG, drop}$	V_{CCREG} to V_{REG} dropout voltage	$I_{REG} = 50 \text{ mA}$			3	V
I_{REGOUT}	Internal V_{REG} voltage regulator output current	VREG pin shorted to ground		125		mA
$I_{REGOUT, STBY}$	Internal V_{REG} voltage regulator output standby current	VREG pin shorted to ground		55		mA
P_{REG}	Internal V_{REG} voltage regulator power dissipation				0.5	W
Integrated analog-to-digital converter						
N_{ADC}	Analog-to-digital converter resolution			5		bit
$V_{ADC, ref}$	Analog-to-digital converter reference voltage			3.3		V
f_s	Analog-to-digital converter sampling frequency	(2)		$f_{OSC}/512$		kHz
$V_{ADC, UVLO}$	ADCIN UVLO threshold		1.05	1.16	1.35	V

1. Guaranteed in the temperature range -25 to 125 °C.
2. The value accuracy is dependent on oscillator frequency accuracy ([Section 6.8](#)).
3. \overline{FLAG} and \overline{BUSY} open drain outputs included.
4. See [Figure 23](#).

4 Pin connection

Figure 2. Pin connection (top view)

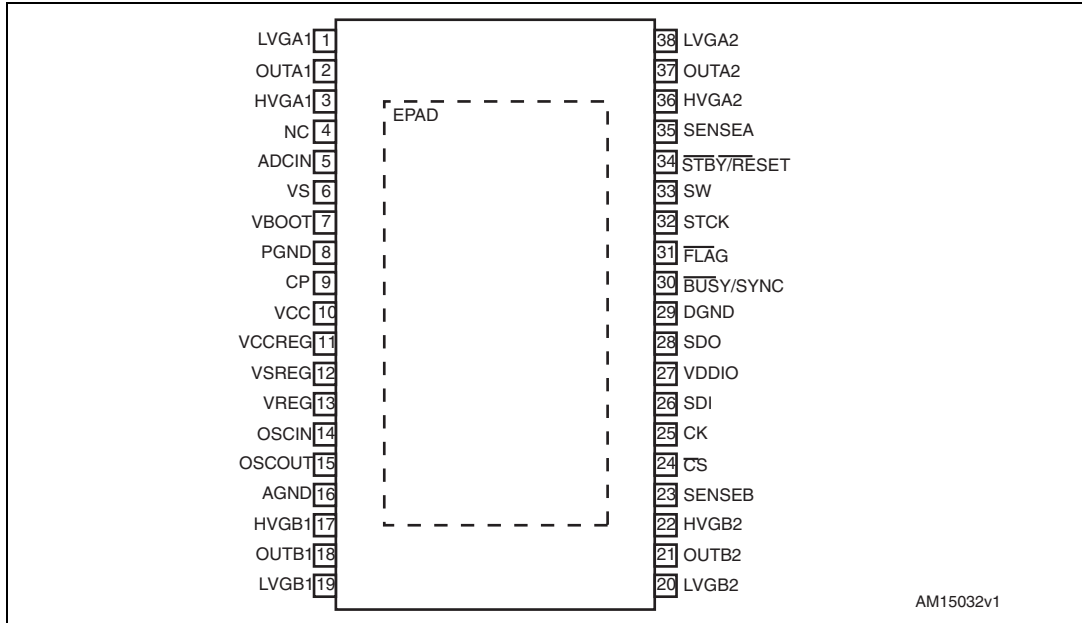

4.1 Pin list

Table 6. Pin description

No.	Name	Type	Function
11	VCCREG	Power supply	Internal V_{REG} voltage regulator supply voltage
13	VREG	Power supply	Logic supply voltage
27	VDD	Power supply	Logic interface supply voltage
12	VSREG	Power supply	Internal V_{CC} voltage regulator supply voltage
10	VCC	Power supply	Gate driver supply voltage
14	OSCIN	Analog input	Oscillator pin1. To connect an external oscillator or clock source
15	OSCOUT	Analog output	Oscillator pin2. To connect an external oscillator. When the internal oscillator is used, this pin can supply a 2/4/8/16 MHz clock
9	CP	Output	Charge pump oscillator output
7	VBOOT	Power supply	Bootstrap voltage needed for driving the high-side power DMOS of both bridges (A and B)
5	ADCIN	Analog input	Internal analog-to-digital converter input
6	VS	Power supply	Motor voltage
3	HVGA1	Power output	High-side half-bridge A1 gate driver output

Table 6. Pin description (continued)

No.	Name	Type	Function
36	HVGA2	Power output	High-side half-bridge A2 gate driver output
17	HVGB1	Power output	High-side half-bridge B1 gate driver output
22	HVGB2	Power output	High-side half-bridge B2 gate driver output
1	LVGA1	Power output	Low-side half-bridge A1 gate driver output
38	LVGA2	Power output	Low-side half-bridge A2 gate driver output
19	LVGB1	Power output	Low-side half-bridge B1 gate driver output
20	LVGB2	Power output	Low-side half-bridge B2 gate driver output
8	PGND	Ground	Power ground pins. They must be connected to other ground pins
35	SENSEA	Analog input	Phase A current sensing input
23	SENSEB	Analog input	Phase B current sensing input
2	OUTA1	Power input	Full-bridge A output 1
37	OUTA2	Power input	Full-bridge A output 2
18	OUTB1	Power input	Full-bridge B output 1
21	OUTB2	Power input	Full-bridge B output 2
16	AGND	Ground	Analog ground. It must be connected to other ground pins
33	SW	Logical input	External switch input pin
29	DGND	Ground	Digital ground. It must be connected to other ground pins
28	SDO	Logical output	Data output pin for serial interface
26	SDI	Logical input	Data input pin for serial interface
25	CK	Logical input	Serial interface clock
24	\overline{CS}	Logical input	Chip select input pin for serial interface
30	$\overline{BUSY}/\text{SYNC}$	Open drain output	By default, the $\overline{BUSY} / \text{SYNC}$ pin is forced low when the device is performing a command. The pin can be programmed in order to generate a synchronization signal
31	\overline{FLAG}	Open drain output	Status flag pin. An internal open drain transistor can pull the pin to GND when a programmed alarm condition occurs (step loss, OCD, thermal pre-warning or shutdown, UVLO, wrong command, non-performable command)
34	\overline{STBY} \overline{RESET}	Logical input	Standby and reset pin. LOW logic level puts the device in Standby mode and reset logic. If not used, it should be connected to V_{REG}
32	STCK	Logical input	Step-clock input
EPAD	Exposed pad	Ground	Exposed pad. It must be connected to other ground pins

5 Typical applications

Table 7. Typical application values

Name	Value
C _{VSPOL}	220 μF
C _{VS}	220 nF
C _{BOOT}	470 nF
C _{FLY}	47 nF
C _{VSREG}	100 nF
C _{VCC}	470 nF
C _{VCCREG}	100 nF
C _{VREG}	100 nF
C _{VREGPOL}	22 μF
C _{VDD}	100 nF
D1	Charge pump diodes
Q1,Q2,Q3,Q4,Q5,Q6,Q7,Q8	STD25NF10
R _{PU}	39 kΩ
R _{SENSE}	0.2 Ω (maximum phase current 5 A)

Figure 3. Typical application schematic

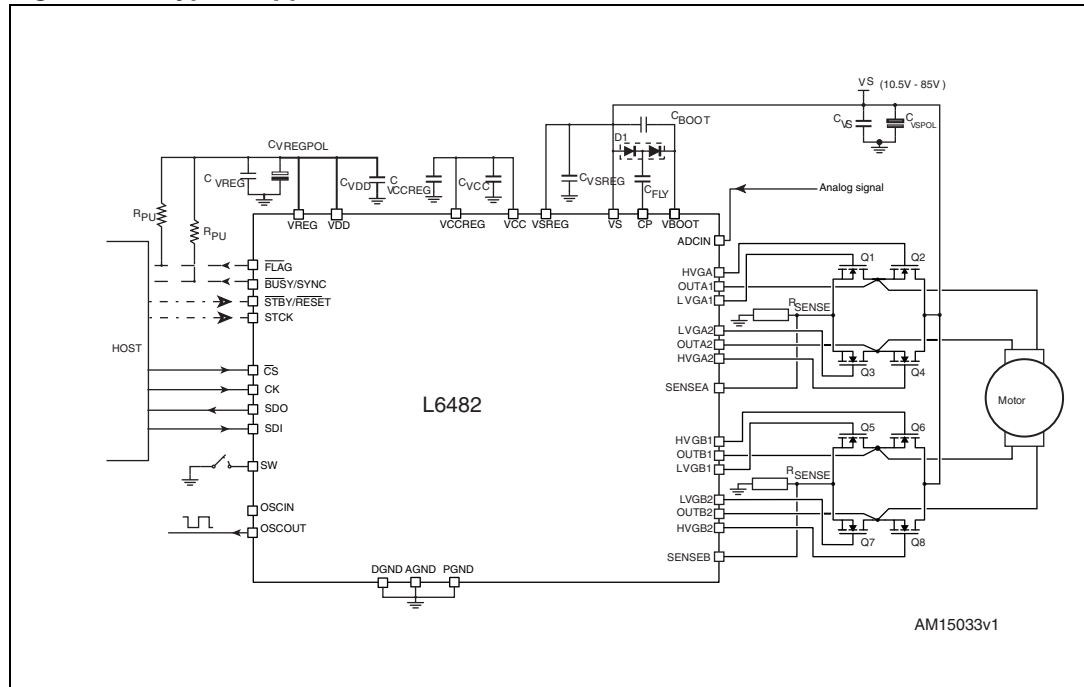

6 Functional description

6.1 Device power-up

During power-up, the device is under reset (all logic IOs disabled and power bridges in high impedance state) until the following conditions are satisfied:

- V_{CC} is greater than V_{CCthOn}
- $V_{BOOT} - V_S$ is greater than $\Delta V_{BOOTthOn}$
- V_{REG} is greater than $V_{REGthOn}$
- Internal oscillator is operative
- $\overline{STBY/RESET}$ input is forced high.

After power-up, the device state is the following:

- Parameters are set to default
- Internal logic is driven by internal oscillator and a 2-MHz clock is provided by the OSCOUT pin
- Bridges are disabled (high impedance).

After power-up, a period of $t_{logicwu}$ must pass before applying a command to allow proper oscillator and logic startup.

Any movement command makes the device exit from High Z state (HardStop and SoftStop included).

6.2 Logic I/O

Pins \overline{CS} , CK, SDI, STCK, SW and $\overline{STBY/RESET}$ are TTL/CMOS 3.3 V-5 V compatible logic inputs.

Pin SDO is a TTL/CMOS compatible logic output. VDD pin voltage imposes a logical output voltage range.

Pins \overline{FLAG} and $\overline{BUSY/SYNC}$ are open drain outputs.

SW and \overline{CS} inputs are internally pulled up to V_{DD} and $\overline{STBY/RESET}$ input is internally pulled down to ground.

6.3 Charge pump

To ensure the correct driving of the high-side integrated MOSFETs, a voltage higher than the motor power supply voltage needs to be applied to the VBOOT pin. The high-side gate driver supply voltage V_{BOOT} is obtained through an oscillator and a few external components realizing a charge pump (see [Figure 4](#)).

Figure 4. Charge pump circuitry

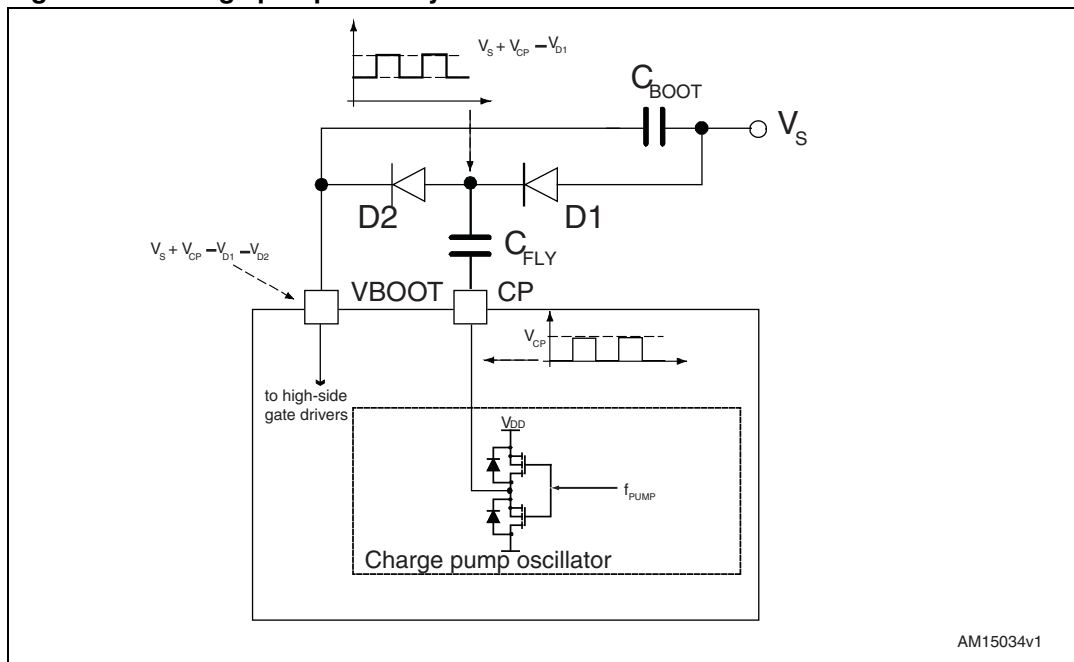

AM15034v1

6.4 Microstepping

The driver is able to divide the single step into up to 16 microsteps. Stepping mode can be programmed by the STEP_SEL parameter in the STEP_MODE register ([Table 22](#)).

Step mode can only be changed when bridges are disabled. Every time the step mode is changed, the electrical position (i.e. the point of microstepping sinewave that is generated) is reset to the first microstep and the absolute position counter value ([Section 6.5](#)) becomes meaningless.

Figure 5. Normal mode and microstepping (16 microsteps)

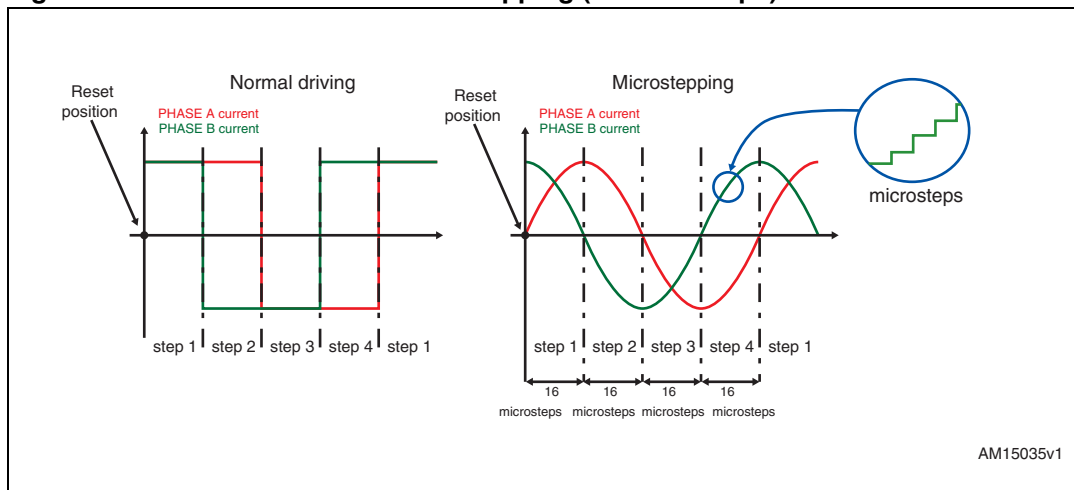

AM15035v1

6.4.1 Automatic Full-step and Boost modes

When motor speed is greater than a programmable full-step speed threshold, the L6482 switches automatically to Full-step mode; the driving mode returns to microstepping when motor speed decreases below the full-step speed threshold.

The switching between the microstepping and Full-step mode and vice versa is always performed at an electrical position multiple of $\pi/4$ (Figure 6 and Figure 7).

Full-step speed threshold is set through the related parameter in the FS_SPD register (Section 9.1.9).

When the BOOST_MODE bit of the FS_SPD register is low (default), the amplitude of the voltage squarewave in Full-step mode is equal to the peak of the voltage sinewave multiplied by $\sin(\pi/4)$ (Figure 6). This avoids the current drop between the two driving modes.

When the BOOST_MODE bit of the FS_SPD register is high, the amplitude of the voltage squarewave in Full-step mode is equal to the peak of the voltage sinewave (Figure 7). That improves the output current increasing the maximum motor torque.

Figure 6. Automatic Full-step switching in Normal mode

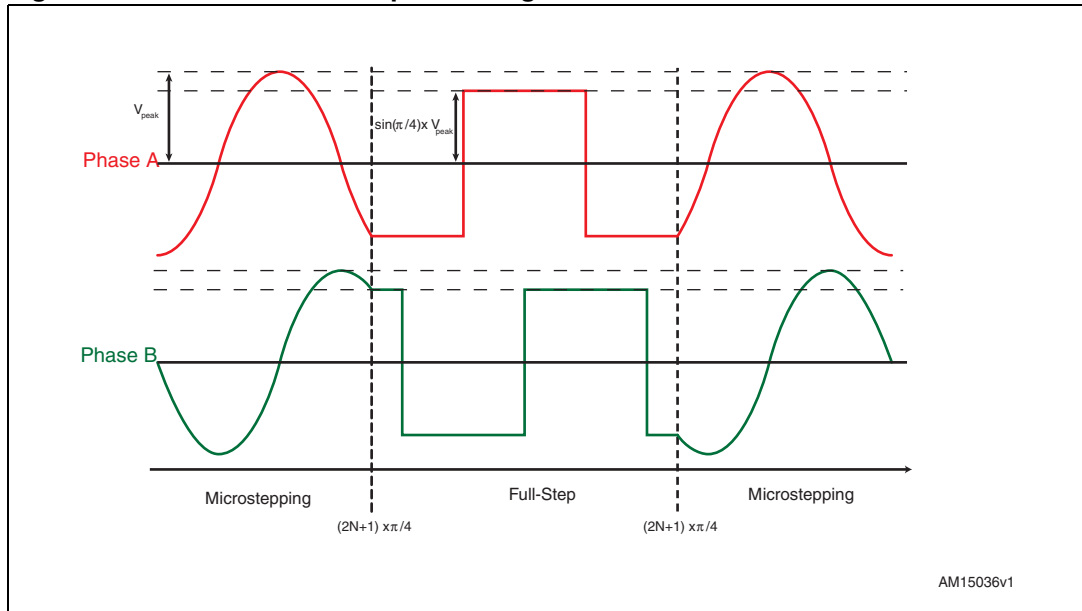
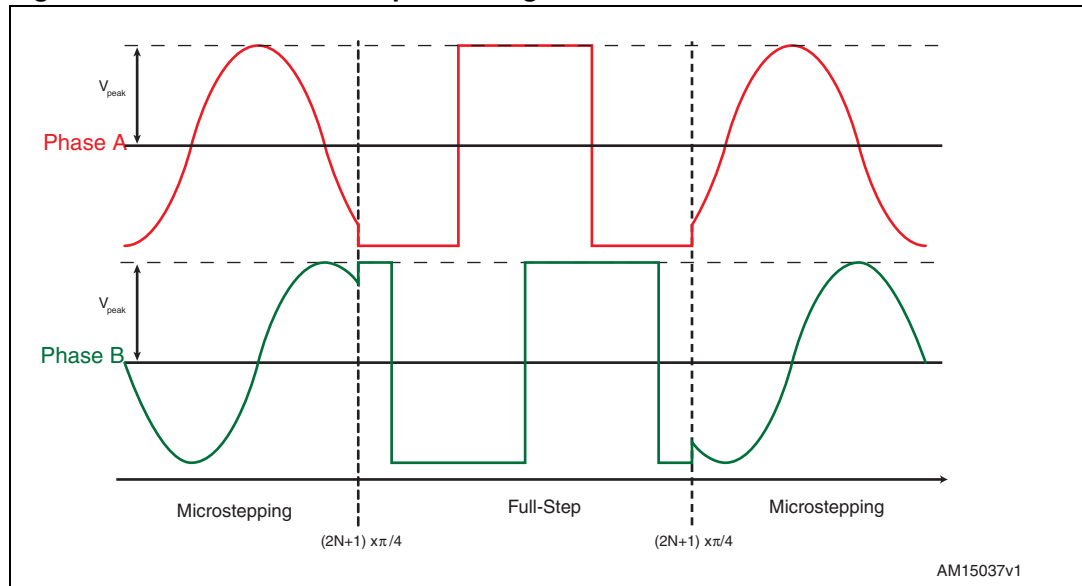

Figure 7. Automatic Full-step switching in Boost mode



6.5 Absolute position counter

An internal 22-bit register (ABS_POS) records all the motor motions according to the selected step mode; the stored value unit is equal to the selected step mode (full, half, quarter, etc.). The position range is from -2^{21} to $+2^{21}-1$ steps (see [Section 9.1.1](#)).

6.6 Programmable speed profiles

The user can easily program a customized speed profile defining independently acceleration, deceleration, and maximum and minimum speed values by ACC, DEC, MAX_SPEED and MIN_SPEED registers respectively (see [Section 9.1.5](#), [9.1.6](#), [9.1.7](#) and [9.1.8](#)).

When a command is sent to the device, the integrated logic generates the microstep frequency profile that performs a motor motion compliant to speed profile boundaries.

All acceleration parameters are expressed in step/tick^2 and all speed parameters are expressed in step/tick ; the unit of measurement does not depend on the selected step mode. Acceleration and deceleration parameters range from 2^{-40} to $(2^{12}-2) \cdot 2^{-40}$ step/tick^2 (equivalent to 14.55 to 59590 step/s^2).

Minimum speed parameter ranges from 0 to $(2^{12}-1) \cdot 2^{-24}$ step/tick (equivalent to 0 to 976.3 step/s).

Maximum speed parameter ranges from 2^{-18} to $(2^{10}-1) \cdot 2^{-18}$ step/tick (equivalent to 15.25 to 15610 step/s).

6.6.1 Infinite acceleration/deceleration mode

When the ACC register value is set to max. (0xFFFF), the system works in “infinite acceleration mode”: acceleration and deceleration phases are totally skipped, as shown in [Figure 8](#). It is not possible to skip the acceleration or deceleration phase independently.

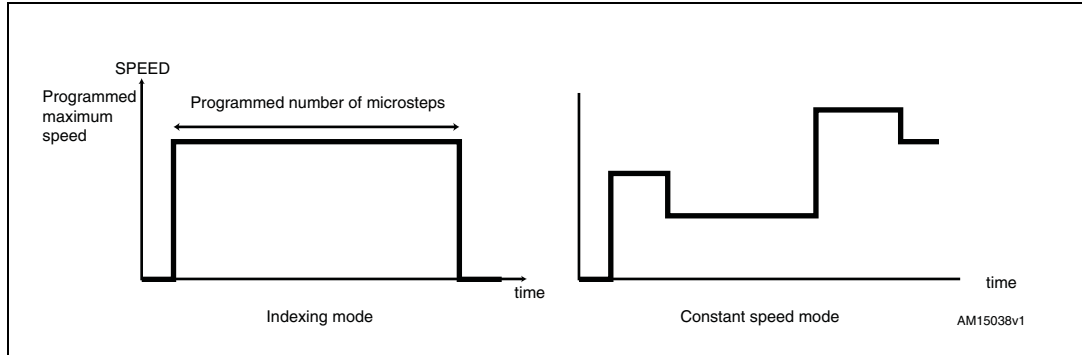
Figure 8. Speed profile in infinite acceleration/deceleration mode

6.7 Motor control commands

The L6482 can accept different types of commands:

- constant speed commands (Run, GoUntil, ReleaseSW)
- absolute positioning commands (GoTo, GoTo_DIR, GoHome, GoMark)
- motion commands (Move)
- stop commands (SoftStop, HardStop, SoftHiz, HardHiz).

For detailed command descriptions refer to [Section 9.2](#).

6.7.1 Constant speed commands

A constant speed command produces a motion in order to reach and maintain a user-defined target speed starting from the programmed minimum speed (set in the MIN_SPEED register) and with the programmed acceleration/deceleration value (set in the ACC and DEC registers). A new constant speed command can be requested anytime.

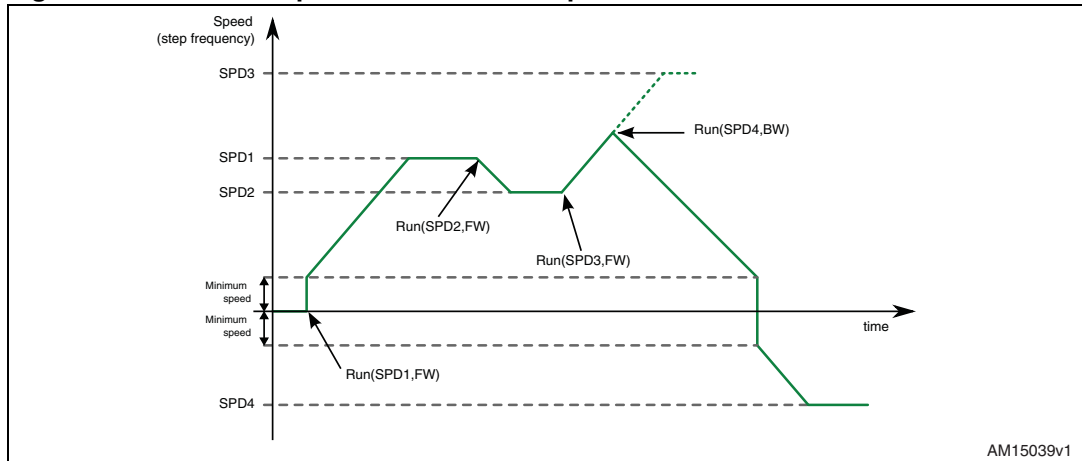
Figure 9. Constant speed command examples

6.7.2 Positioning commands

An absolute positioning command produces a motion in order to reach a user-defined position that is sent to the device together with the command. The position can be reached

performing the minimum path (minimum physical distance) or forcing a direction (see [Figure 10](#)).

Performed motor motion is compliant to programmed speed profile boundaries (acceleration, deceleration, minimum and maximum speed).

Note that with some speed profiles or positioning commands, the deceleration phase can start before the maximum speed is reached.

Figure 10. Positioning command examples

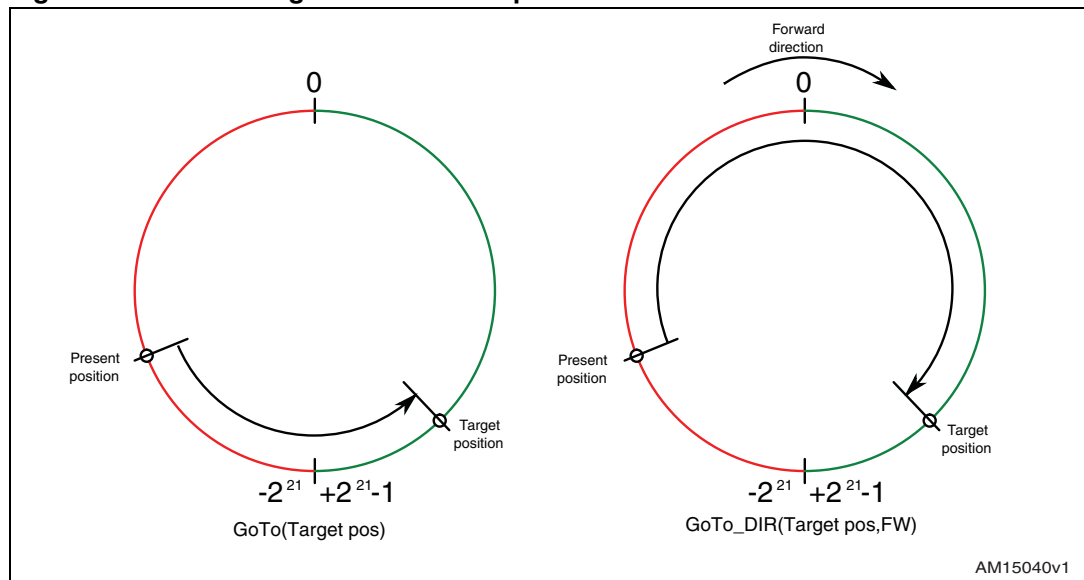

6.7.3 Motion commands

Motion commands produce a motion in order to perform a user-defined number of microsteps in a user-defined direction that are sent to the device together with the command (see [Figure 11](#)).

Performed motor motion is compliant to programmed speed profile boundaries (acceleration, deceleration, minimum and maximum speed).

Note that with some speed profiles or motion commands, the deceleration phase can start before the maximum speed is reached.

Figure 11. Motion command examples

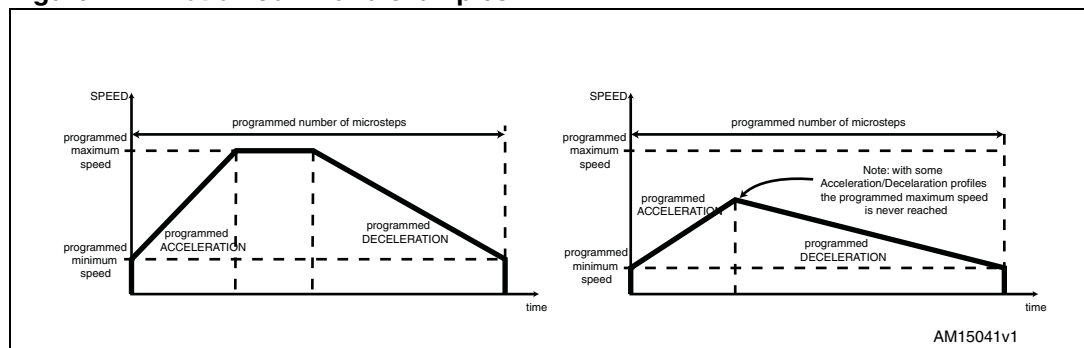

6.7.4 Stop commands

A stop command forces the motor to stop. Stop commands can be sent anytime.

The SoftStop command causes the motor to decelerate with a programmed deceleration value until the MIN_SPEED value is reached and then stops the motor keeping the rotor position (a holding torque is applied).

The HardStop command stops the motor instantly, ignoring deceleration constraints and keeping the rotor position (a holding torque is applied).

The SoftHiZ command causes the motor to decelerate with a programmed deceleration value until the MIN_SPEED value is reached and then forces the bridges into high impedance state (no holding torque is present).

The HardHiZ command instantly forces the bridges into high impedance state (no holding torque is present).

6.7.5 Step-clock mode

In Step-clock mode the motor motion is defined by the step-clock signal applied to the STCK pin. At each step-clock rising edge, the motor is moved one microstep in the programmed direction and the absolute position is consequently updated.

When the system is in Step-clock mode, the SCK_MOD flag in the STATUS register is raised, the SPEED register is set to zero and the motor status is considered stopped regardless of the STCK signal frequency (the MOT_STATUS parameter in the STATUS register equal to "00").

6.7.6 GoUntil and ReleaseSW commands

In most applications the power-up position of the stepper motor is undefined, so an initialization algorithm driving the motor to a known position is necessary.

The GoUntil and ReleaseSW commands can be used in combination with external switch input (see [Section 6.14](#)) to easily initialize the motor position.

The GoUntil command makes the motor run at target constant speed until the SW input is forced low (falling edge). When this event occurs, one of the following actions can be performed:

- ABS_POS register is set to zero (home position) and the motor decelerates to zero speed (as a SoftStop command)
- ABS_POS register value is stored in the MARK register and the motor decelerates to zero speed (as a SoftStop command).

If the SW_MODE bit of the CONFIG register is set to '0', the motor does not decelerate but it immediately stops (as a HardStop command).

The ReleaseSW command makes the motor run at a programmed minimum speed until the SW input is forced high (rising edge). When this event occurs, one of the following actions can be performed:

- ABS_POS register is set to zero (home position) and the motor immediately stops (as a HardStop command)
- ABS_POS register value is stored in the MARK register and the motor immediately stops (as a HardStop command).

If the programmed minimum speed is less than 5 step/s, the motor is driven at 5 step/s.

6.8 Internal oscillator and oscillator driver

The control logic clock can be supplied by the internal 16-MHz oscillator, an external oscillator (crystal or ceramic resonator) or a direct clock signal.

These working modes can be selected by EXT_CLK and OSC_SEL parameters in the CONFIG register (see [Table 35](#)).

At power-up the device starts using the internal oscillator and provides a 2-MHz clock signal on the OSCOUT pin.

Attention: In any case, before changing clock source configuration, a hardware reset is mandatory. Switching to different clock configurations during operation may cause unexpected behavior.

6.8.1 Internal oscillator

In this mode the internal oscillator is activated and OSCIN is unused. If the OSCOUT clock source is enabled, the OSCOUT pin provides a 2, 4, 8 or 16-MHz clock signal (according to OSC_SEL value); otherwise it is unused (see [Figure 12](#)).

6.8.2 External clock source

Two types of external clock source can be selected: crystal/ceramic resonator or direct clock source. Four programmable clock frequencies are available for each external clock source: 8, 16, 24 and 32-MHz.

When an external crystal/resonator is selected, the OSCIN and OSCOUT pins are used to drive the crystal/resonator (see [Figure 12](#)). The crystal/resonator and load capacitors (C_L) must be placed as close as possible to the pins. Refer to [Table 8](#) for the choice of the load capacitor value according to the external oscillator frequency.

Table 8. CL values according to external oscillator frequency

Crystal/resonator frequency ⁽¹⁾	C_L ⁽²⁾
8 MHz	25 pF (ESR _{max} = 80 Ω)
16 MHz	18 pF (ESR _{max} = 50 Ω)
24 MHz	15 pF (ESR _{max} = 40 Ω)
32 MHz	10 pF (ESR _{max} = 40 Ω)

1. First harmonic resonance frequency.

2. Lower ESR value allows greater load capacitors to be driven.

If a direct clock source is used, it must be connected to the OSCIN pin and the OSCOUT pin supplies the inverted OSCIN signal (see [Figure 12](#)).

The L6482 integrates a clock detection system that resets the device in the case of a failure of the external clock source (direct or crystal/resonator). The monitoring of the clock source is disabled by default, it can be enabled setting high the WD_EN bit in the GATECFG1

register ([Section 9.1.18](#)). When the external clock source is selected, the device continues to work with the integrated oscillator for t_{extosc} milliseconds and then the clock management system switches to the OSCIN input.

Figure 12. OSCIN and OSCOUT pin configuration

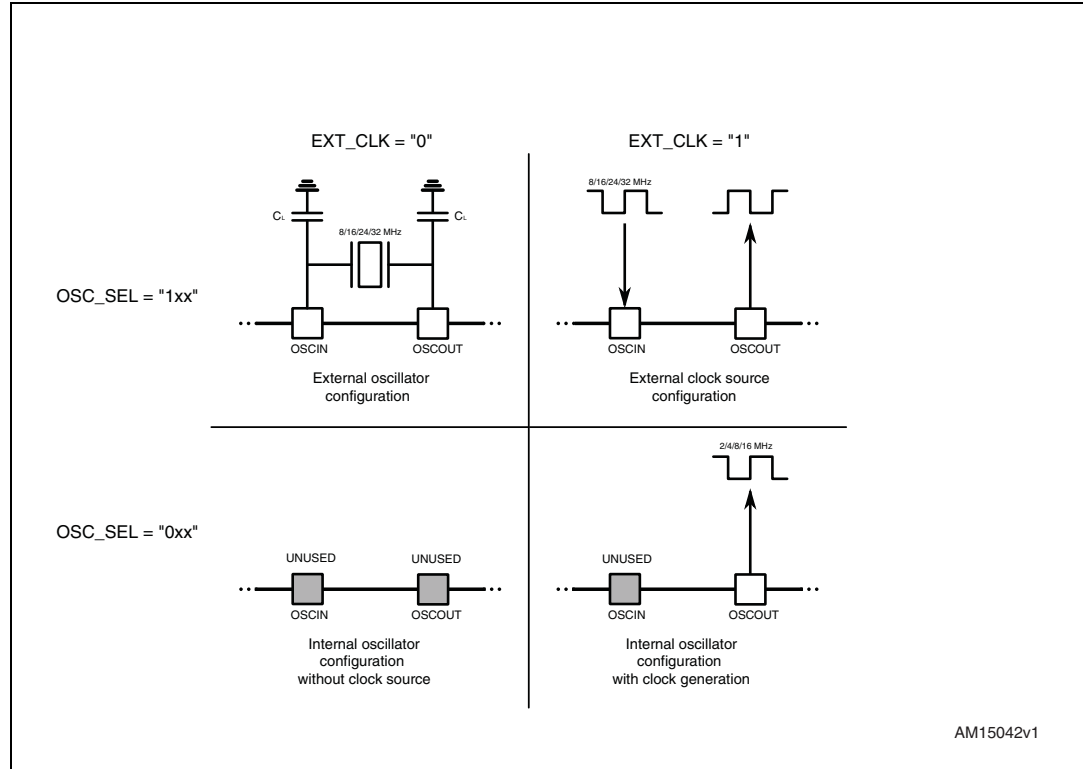

Note: When OSCIN is UNUSED, it should be left floating.
When OSCOUT is UNUSED, it should be left floating.

6.9 Overcurrent detection

The L6482 measures the load current of each half-bridge sensing the V_{DS} voltage of all the Power MOSFETs ([Figure 13](#)). When any of the V_{DS} voltages rise above the programmed threshold, the OCD flag in the STATUS register is forced low until the event expires and a GetStatus command is sent to the device ([Section 9.1.21](#) and [Section 9.2.20](#)). The overcurrent event expires when all the Power MOSFET V_{DS} voltages fall below the programmed threshold.

The overcurrent threshold can be programmed by the OCD_TH register in one of 32 available values ranging from 31.25 mV to 1 V with steps of 31.25 mV ([Table 21](#), [Section 9.1.17](#)).

Figure 13. Overcurrent detection-principle scheme

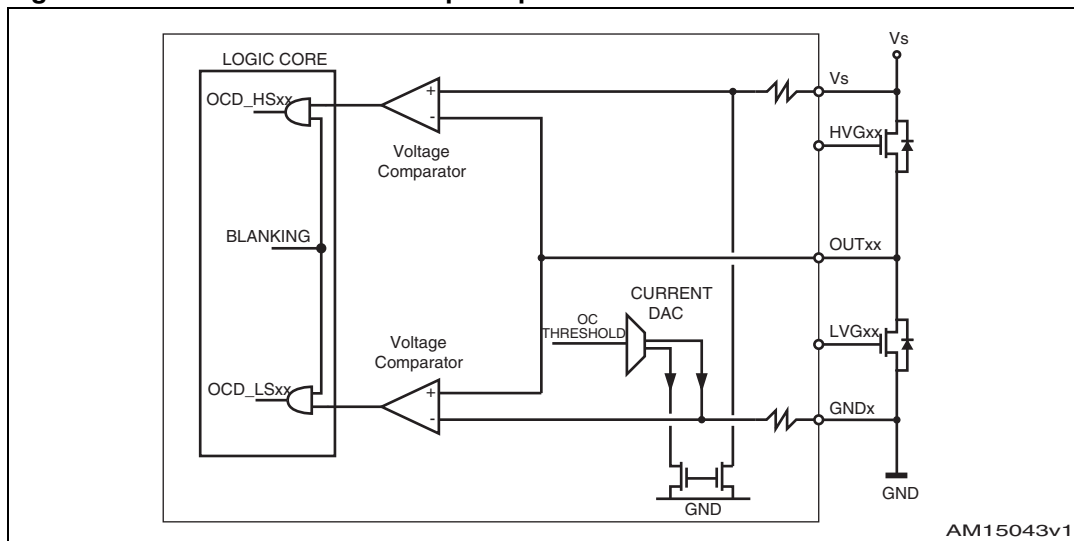

The overcurrent detection comparators are disabled, in order to avoid wrong voltage measurements, in the following cases:

- The respective half-bridge is in high impedance state (both gates forced off)
- The respective half-bridge is commutating
- The respective half-bridge is commutated and the programmed blanking time has not yet elapsed
- The respective gate is turned off.

It is possible to set, if an overcurrent event causes the bridge turn-off or not, through the OC_SD bit in the CONFIG register.

When the power bridges are turned off by an overcurrent event, they cannot be turned on until the OCD flag is released by a GetStatus command.

6.10 Undervoltage lockout (UVLO)

The L6482 provides a programmable gate driver supply voltage UVLO protection. When one of the supply voltages of the gate driver (V_{CC} for the low sides and $V_{BOOT} - V_S$ for the high sides) falls below the respective turn-off threshold, an undervoltage event occurs. In this case, all gates are immediately turned off and the UVLO flag in the STATUS register is forced low.

The UVLO flag is forced low and the gates are kept off until the gate driver supply voltages return to above the respective turn-on threshold; in this case the undervoltage event expires and the UVLO flag can be released through a GetStatus command.

The UVLO thresholds can be selected between two sets according to the UVLOVAL bit value in the CONFIG register.

Table 9. UVLO thresholds

	UVLOVAL	
	0	1
Low-side gate driver supply turn-off threshold ($V_{CCthOff}$)	6.3 V	10 V
Low-side gate driver supply turn-on threshold (V_{CCthOn})	6.9 V	10.4 V
High-side gate driver supply turn-off threshold ($\Delta V_{BOOTthOff}$)	5.5 V	8.8 V
High-side gate driver supply turn-on threshold ($\Delta V_{BOOTthOn}$)	6 V	9.2 V

6.11 VS undervoltage lockout (UVLO_ADC)

The device provides an undervoltage signal of the integrated ADC input voltage (the UVLO_ADC flag in the STATUS register). When V_{ADCIN} falls below the $V_{ADC,UVLO}$ value, the UVLO_ADC flag is forced low and it is kept in this state until the ADCIN voltage is greater than $V_{ADC,UVLO}$ and a GetStatus command is sent to the device.

The ADCIN undervoltage event does not turn off the gates of the power bridges.

The motor supply voltage undervoltage detection can be performed by means of this feature, connecting the ADCIN pin to VS through a voltage divider.

6.12 Thermal warning and thermal shutdown

An integrated sensor allows detection of the internal temperature and implementation of a 3-level protection.

When the $T_{j(WRN)Set}$ threshold is reached, a warning signal is generated. This is the thermal warning condition and it expires when the temperature falls below the $T_{j(WRN)Rel}$ threshold.

When the $T_{j(OFF)Set}$ threshold is reached, all the gates are turned off and the gate driving circuitry is disabled (Miller clamps are still operative). This condition expires when the temperature falls below the $T_{j(OFF)Rel}$ threshold.

When the $T_{j(SD)OFF}$ threshold is reached, all the gates are turned off using Miller clamps, the internal V_{CC} voltage regulator is disabled and the current capability of the internal V_{REG} voltage regulator is reduced (thermal shutdown). In this condition, logic is still active (if supplied). The thermal shutdown condition only expires when the temperature goes below $T_{j(SD)ON}$.

The thermal condition of the device is shown by TH_STATUS bits in the STATUS register ([Table 10](#)).

Table 10. Thermal protection summarizing table

State	Set condition	Release condition	Description	TH_STATUS
Normal			Normal operation state	00
Warning	$T_j > T_{j(WRN)Set}$	$T_j > T_{j(WRN)Rel}$	Temperature warning: operation is not limited	01
Bridge shutdown	$T_j > T_{j(OFF)Set}$	$T_j > T_{j(OFF)Rel}$	High temperature protection: the gates are turned off and the gate drivers are disabled	10
Device shutdown	$T_j > T_{j(SD)Set}$	$T_j > T_{j(SD)Rel}$	Overtemperature protection: the gates are turned off, the gate drivers are disabled, the internal V_{CC} voltage regulator is disabled, the current capability of the internal V_{REG} voltage regulator is limited, and the charge pump is disabled	11

6.13 Reset and standby

The device can be reset and put into Standby mode through the $\overline{STBY/RESET}$ pin. When it is forced low, all the gates are turned off (High Z state), the charge pump is stopped, the SPI interface and control logic are disabled and the internal V_{REG} voltage regulator maximum output current is limited; as a result, the L6482 heavily reduces the power consumption. At the same time the register values are reset to their default and all the protection functions are disabled. The $\overline{STBY/RESET}$ input must be forced low at least for $t_{STBY,min}$ in order to ensure the complete switch to Standby mode.

On exiting Standby mode, as well as for IC power-up, a delay must be given before applying a new command to allow proper oscillator and charge pump startup. Actual delay could vary according to the values of the charge pump external components.

On exiting Standby mode all the gates are off and the HiZ flag is high.

The registers can be reset to the default values without putting the device into Standby mode through the ResetDevice command ([Section 9.2.15](#)).

6.14 External switch (SW pin)

The SW input is internally pulled up to V_{DD} and detects if the pin is open or connected to ground (see [Figure 14](#)).

The SW_F bit of the STATUS register indicates if the switch is open ('0') or closed ('1') ([Section 9.1.21](#)); the bit value is refreshed at every system clock cycle (125 ns). The SW_EVN flag of the STATUS register is raised when a switch turn-on event (SW input falling edge) is detected ([Section 9.1.21](#)). A GetStatus command releases the SW_EVN flag ([Section 9.2.20](#)).

By default, a switch turn-on event causes a HardStop interrupt (SW_MODE bit of the CONFIG register set to '0'). Otherwise (SW_MODE bit of the CONFIG register set to '1'),

switch input events do not cause interrupts and the switch status information is at the user's disposal ([Table 36](#), [Section 9.1.20](#)).

The switch input can be used by GoUntil and ReleaseSW commands as described in [Section 9.2.10](#) and [Section 9.2.11](#).

If the SW input is not used, it should be connected to V_{DD} .

Figure 14. External switch connection

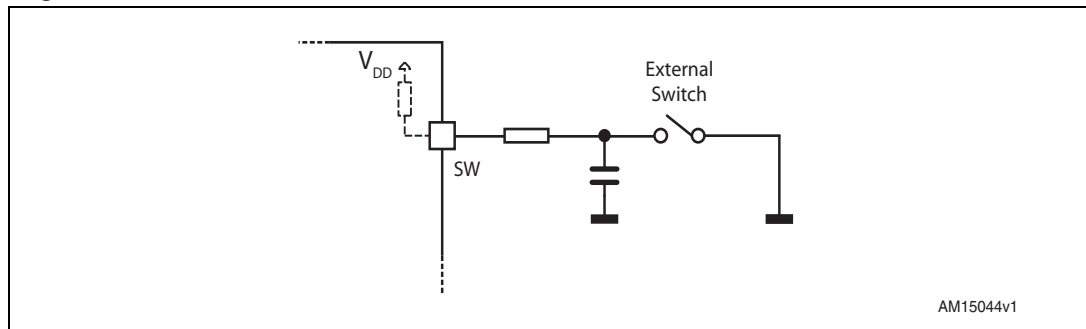

6.15 Programmable gate drivers

The L6482 integrates eight programmable gate drivers that allow the fitting of a wide range of applications.

The following parameters can be adjusted:

- gate sink/source current (I_{GATE})
- controlled current time (t_{CC})
- turn-off overboost time (t_{OB}).

During turn-on, the gate driver charges the gate forcing an I_{GATE} current for all the controlled current time period. At the end of the controlled current phase the gate of the external MOSFET should be completely charged, otherwise the gate driving circuitry continues to charge it using a holding current.

This current is equal to I_{GATE} for the low-side gate drivers and 1 mA for the high-side ones.

During turn-off, the gate driver discharges the gate sinking an I_{GATE} current for all the controlled current time period. At the beginning of turn-off an overboost phase can be added: in this case the gate driver sinks an I_{OB} current for the programmed t_{OB} period in order to rapidly reach the plateau region. At the end of the controlled current time the gate of the external MOSFET should be completely charged, otherwise the gate driving circuitry discharges it using the integrated Miller clamp.

Figure 15. Gate driving currents

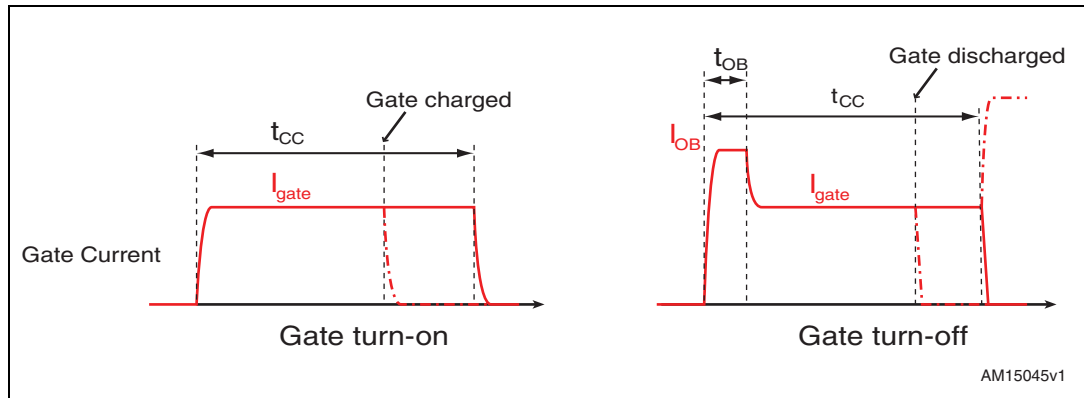

The gate current can be set to one of the following values: 4, 8, 16, 24, 32, 64 and 96 mA through the IGATE parameter in the GATECFG1 register (see [Section 9.1.18](#)).

Controlled current time can be programmed within range from 125 ns to 3.75 μ s with a resolution of 125 ns (TCC parameter in the GATECFG1 register) (see [Section 9.1.18](#)).

Turn-off overboost time can be set to one of the following values: 0, 62.5, 125, 250 ns (TBOOST parameter in the GATECFG1 register). The 62.5 ns value is only available when clock frequency is 16 MHz or 32 MHz; when clock frequency is 8 MHz it is changed to 125 ns and when a 24-MHz clock is used it is changed to 83.3 ns. (see [Section 9.1.18](#)).

6.16 Deadtime and blanking time

During the bridge commutation, a deadtime is added in order to avoid cross conductions. The deadtime can be programmed within a range from 125 ns to 4 μ s with a resolution of 125 ns (TDT parameter in the GATECFG2 register) (see [Section 9.1.19](#)).

At the end of each commutation the overcurrent and stall detection comparators are disabled (blanking) in order to avoid the respective systems detecting body diode turn-off current peaks.

The duration of blanking time is programmable through the TBLANK parameter in the GATECFG2 register at one of the following values: 125, 250, 375, 500, 625, 750, 875, 1000 ns (see [Section 9.1.19](#)).

6.17 Integrated analog-to-digital converter

The L6482 integrates an N_{ADC} bit ramp-compare analog-to-digital converter with a reference voltage equal to V_{REG} . The analog-to-digital converter input is available through the ADCIN pin and the conversion result is available in the ADC_OUT register ([Section 9.1.14](#)).

The ADC_OUT value can be used for torque regulation or can be at the user's disposal.

6.18 Supply management and internal voltage regulators

The L6482 integrates two linear voltage regulators: the first one can be used to obtain gate driver supply starting from a higher voltage (e.g. the motor supply one). Its output voltage can be set to 7.5 V or 15 V according to the VCCVAL bit value (CONFIG register). The second linear voltage regulator can be used to obtain the 3.3 V logic supply voltage.

The regulators are designed to supply the internal circuitry of the IC and should not be used to supply external components.

The input and output voltages of both regulators are connected to external pins and the regulators are totally independent: in this way a very flexible supply management can be performed using external components or external supply voltages ([Figure 16](#)).

Figure 16. Device supply pin management

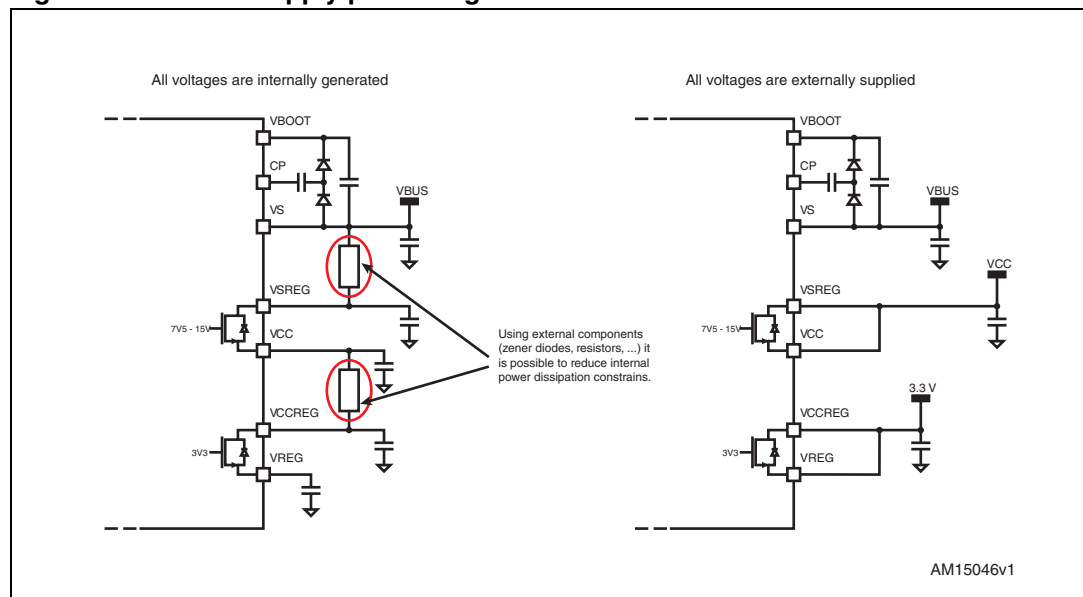

If V_{CC} is externally supplied, the VSREG and VCC pins must be shorted (V_{SREG} must be compliant with V_{CC} range).

If V_{REG} is externally supplied, the VCCREG and VREG pins must be shorted and equal to 3.3 V.

V_{SREG} must be always less than V_{BOOT} in order to avoid related ESD protection diode turn-on. The device can be protected from this event by adding an external low drop diode between the VSREG and VS pins, charge pump diodes should be low drop too.

V_{CCREG} must be always less than V_{CC} in order to avoid ESD protection diode turn-on. The device can be protected from this event by adding an external low drop diode between the VCCREG and VSREG pins.

Both regulators provide a short-circuit protection limiting the load current within the respective maximum ratings.

6.19 BUSY/SYNC pin

This pin is an open drain output which can be used as busy flag or synchronization signal according to the SYNC_EN bit value (STEP_MODE register) (see [Section 9.1.17](#)).

6.20 FLAG pin

By default, an internal open drain transistor pulls the $\overline{\text{FLAG}}$ pin to ground when at least one of the following conditions occurs:

- Power-up or standby/reset exit
- Overcurrent detection
- Thermal warning
- Thermal shutdown
- UVLO
- UVLO on ADC input
- Switch turn-on event
- Command error.

It is possible to mask one or more alarm conditions by programming the ALARM_EN register (see [Section 9.1.17 Table 26](#)). If the corresponding bit of the ALARM_EN register is low, the alarm condition is masked and it does not cause a FLAG pin transition; all other actions imposed by alarm conditions are performed anyway. In case of daisy chain configuration, FLAG pins of different ICs can be OR-wired to save host controller GPIOs.

7 Phase current control

The L6482 performs a new current control technique, named predictive current control, allowing the device to obtain the target average phase current. This method is described in detail in [Section 7.1](#). Furthermore, the L6482 automatically selects the better decay mode in order to follow the current profile.

Current control algorithm parameters can be programmed by T_FAST, TON_MIN, TOFF_MIN and CONFIG registers (see [Section 9.1.11](#), [9.1.12](#), [9.1.13](#) and [9.1.20](#) for details).

Different current amplitude can be set for acceleration, deceleration and constant speed phases and when the motor is stopped through TVAL_ACC, TVAL_DEC, TVAL_RUN and TVAL_HOLD registers (see [Section 9.1.10](#)). The output current amplitude can also be regulated by the ADCIN voltage value (see [Section 7.4](#)).

Each bridge is driven by an independent control system that shares with the other bridge the control parameters only.

7.1 Predictive current control

Unlike classical peak current control systems, that make the phase current decay when the target value is reached, this new method keeps the power bridge ON for an extra time after reaching the current threshold.

At each cycle the system measures the time required to reach the target current (tSENSE). After that the power stage is kept in a “predictive” ON state (tPRED) for a time equal to the mean value of tSENSE in the last two control cycles (actual one and previous one), as shown in [Figure 17](#).

Figure 17. Predictive current control

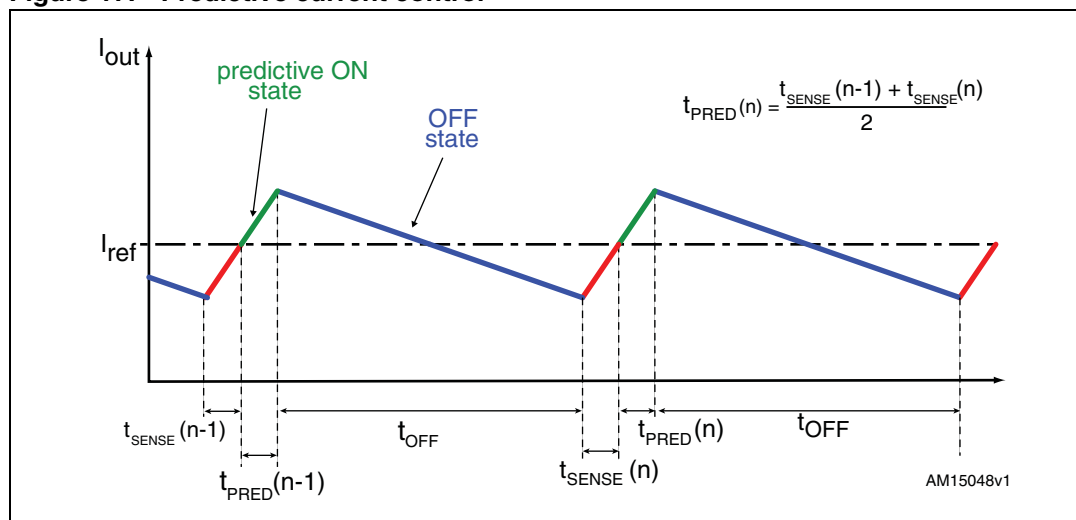

At the end of the predictive ON state the power stage is set in OFF state for a fixed time, as in a constant tOFF current control. During the OFF state both slow and fast decay can be performed; the better decay combination is automatically selected by the L6482, as described in [Section 7.2](#).

As shown in [Figure 17](#), the system is able to center the triangular wave on the desired reference value, improving dramatically the accuracy of the current control system: in fact the average value of a triangular wave is exactly equal to the middle point of each of its segment and at steady-state the predictive current control tends to equalize the duration of the t_{SENSE} and the t_{PRED} time.

Furthermore, the t_{OFF} value is recalculated each time a new current value is requested (microstep change) in order to keep the PWM frequency as near as possible to the programmed one (TSW parameter in the CONFIG register).

The device can be forced to work using classic peak current control setting low the PRED_EN bit in the CONFIG register (default condition). In this case, after the sense phase (t_{SENSE}) the power stage is set in OFF state, as shown in [Figure 18](#).

Figure 18. Non-predictive current control

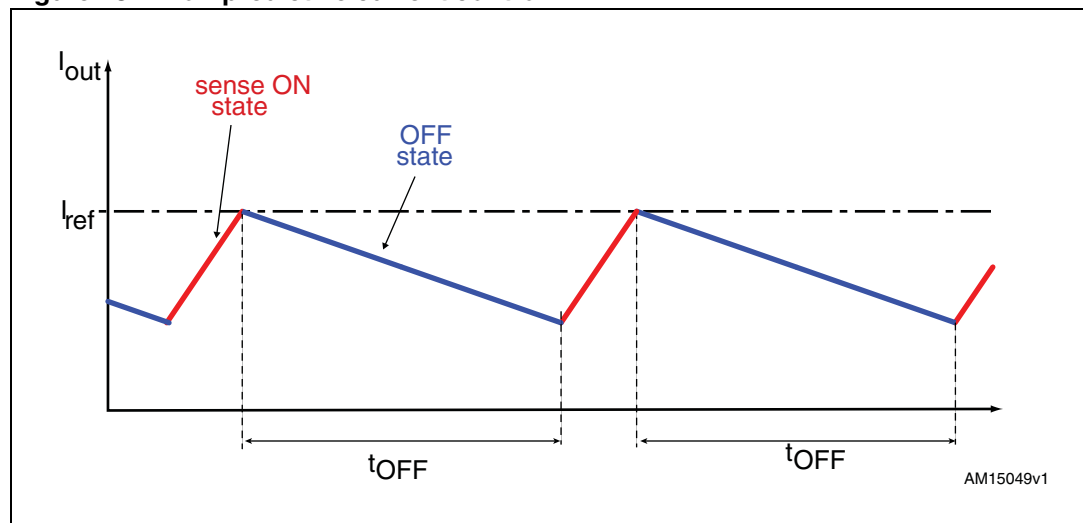

7.2 Auto-adjusted decay mode

During the current control, the device automatically selects the better decay mode in order to follow the current profile reducing the current ripple.

At reset, the off-time is performed turning on both the low-side MOS of the power stage and the current recirculates in the lower half of the bridge (slow decay).

If, during a PWM cycle, the target current threshold is reached in a time shorter than the T_{ON_MIN} value, a fast decay of $TOFF_FAST/8$ (T_FAST register) is immediately performed turning on the opposite MOS of both half-bridges and the current recirculates back to the supply bus.

After this time, the bridge returns to ON state: if the time needed to reach the target current value is still less than T_{ON_MIN} , a new fast decay is performed with a period twice the previous one. Otherwise, the normal control sequence is followed as described in [Section 7.1](#). The maximum fast decay duration is set by the $TOFF_FAST$ value.

Figure 19. Adaptive decay - fast decay tuning

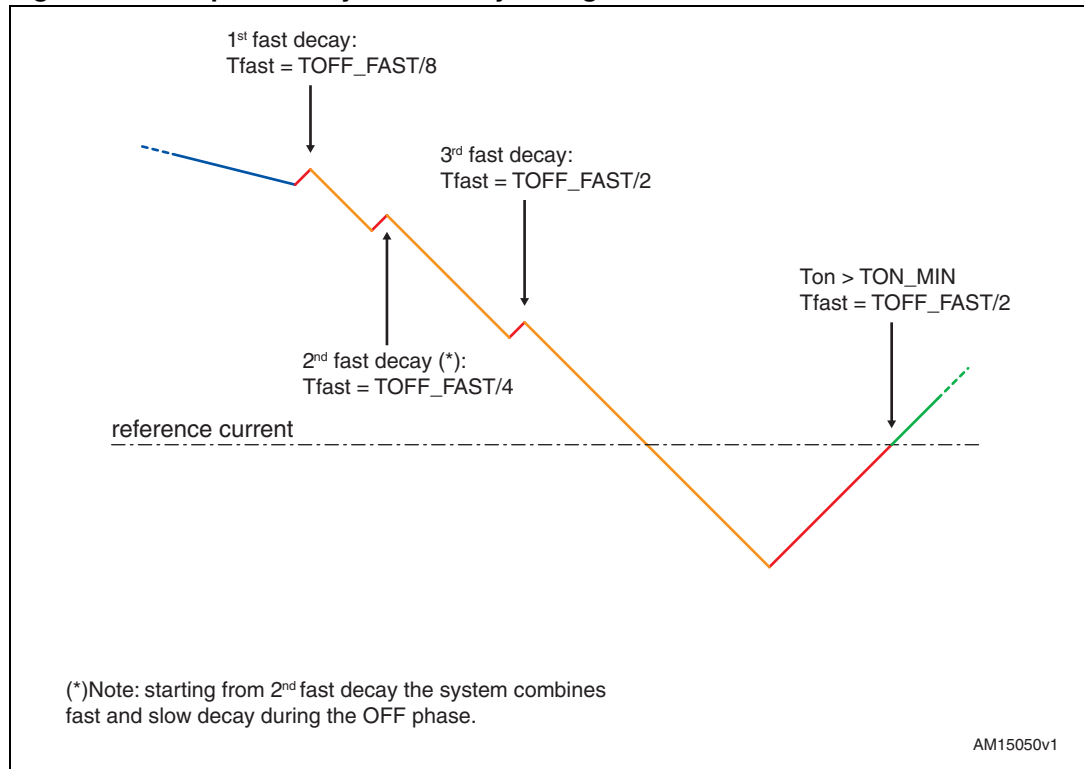

When two or more fast decays are performed with the present target current, the control system adds a fast decay at the end of every off-time keeping the OFF state duration constant (t_{OFF} is split into $t_{OFF, SLOW}$ and $t_{OFF, FAST}$). When the current threshold is increased by a microstep change (rising step), the system returns to normal decay mode (slow decay only) and the t_{FAST} value is halved.

Stopping the motor or reaching the current sinewave zero crossing causes the current control system to return to the reset state.

Figure 20. Adaptive decay - switch from normal to slow+fast decay mode and vice versa

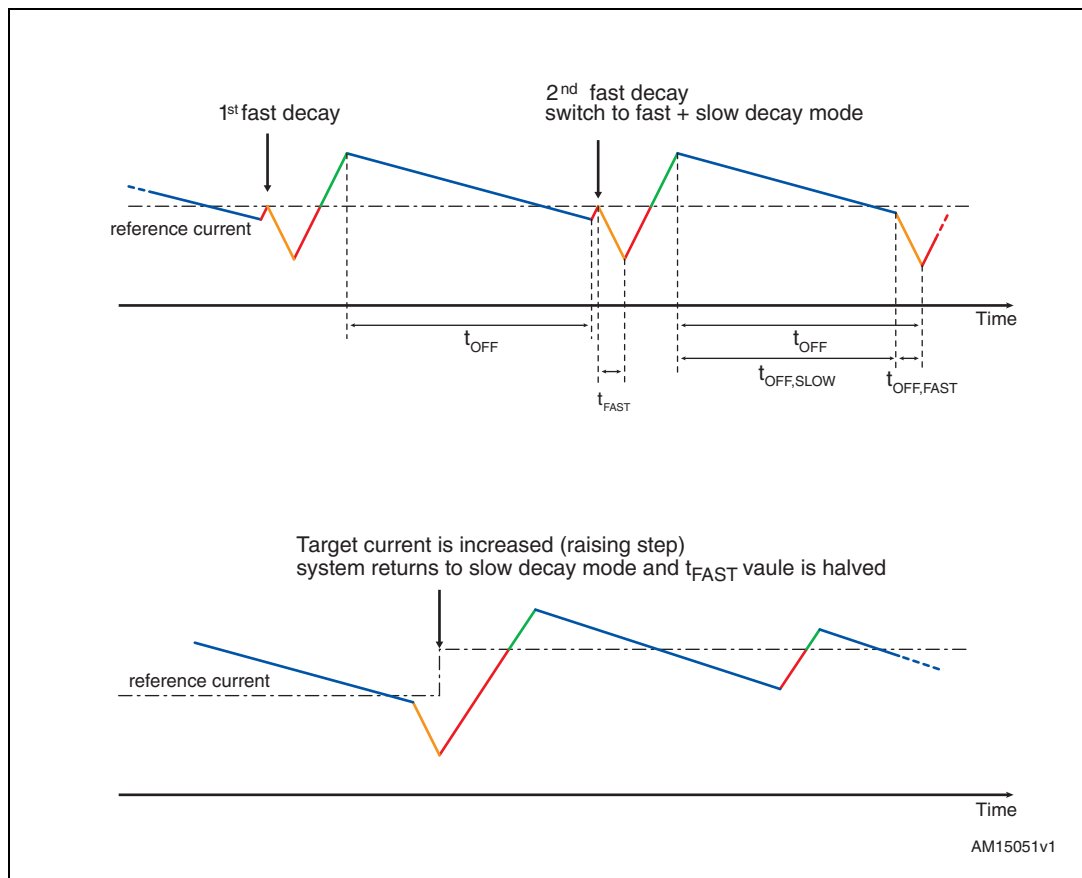

7.3 Auto-adjusted fast decay during the falling steps

When the target current is decreased by a microstep change (falling step), the device performs a fast decay in order to reach the new value as fast as possible. However, exceeding the fast duration could cause a strong ripple on the step change. The L6482 automatically adjusts these fast decays reducing the current ripple.

At reset the fast decay value (t_{FALL}) is set to $FALL_STEP/4$ (T_FAST register). The t_{FALL} value is doubled every time, within the same falling step, an extra fast decay is necessary to obtain an on-time greater than TON_MIN (see [Section 9.1.12](#)). The maximum t_{FALL} value is equal to $FALL_STEP$.

At the next falling step, the system uses the last t_{FALL} value of the previous falling step.

Stopping the motor or reaching the current sinewave zero crossing causes the current control system to return to the reset state.

Figure 21. Fast decay tuning during the falling steps

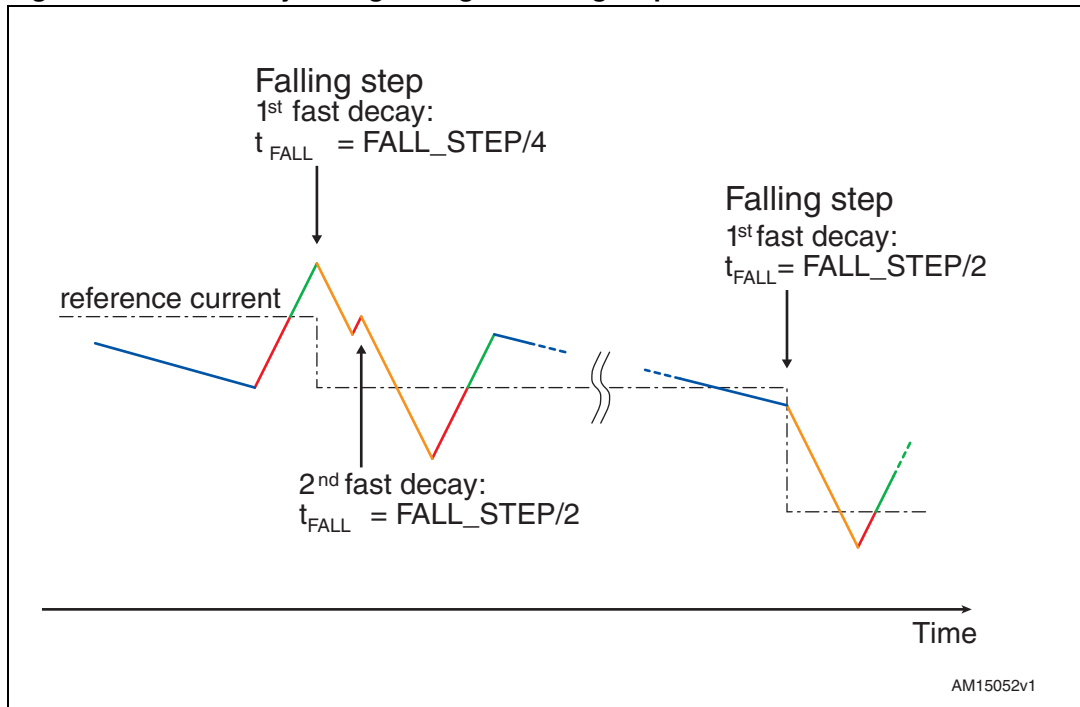

7.4 Torque regulation (output current amplitude regulation)

The phase currents are monitored through two shunt resistors (one for each power bridge) connected to the respective sense pin (see [Figure 22](#)). The integrated comparator compares the sense resistor voltage with the internal reference generated using the peak value, which is proportional to the output current amplitude, and the microstepping code. The comparison result is provided to the logic in order to implement the current control algorithm as described in previous sections.

The peak reference voltage can be regulated in two ways: writing TVAL_ACC, TVAL_DEC, TVAL_RUN and TVAL_HOLD registers or varying the ADCIN voltage value.

The EN_TQREG bit (CONFIG register) sets the torque regulation method. If this bit is high, ADC_OUT prevalue is used to regulate output current amplitude (see [Table 20](#), [Section 9.1.14](#)). Otherwise the internal analog-to-digital converter is at the user's disposal and the output current amplitude is managed by TVAL_HOLD, TVAL_RUN, TVAL_ACC and TVAL_DEC registers (see [Table 14](#), [Section 9.1.10](#)).

The voltage applied to the ADCIN pin is sampled at fS frequency and converted in an NADC bit digital signal. The analog-to-digital conversion result is available in the ADC_OUT register.

Figure 22. Current sensing and reference voltage generation

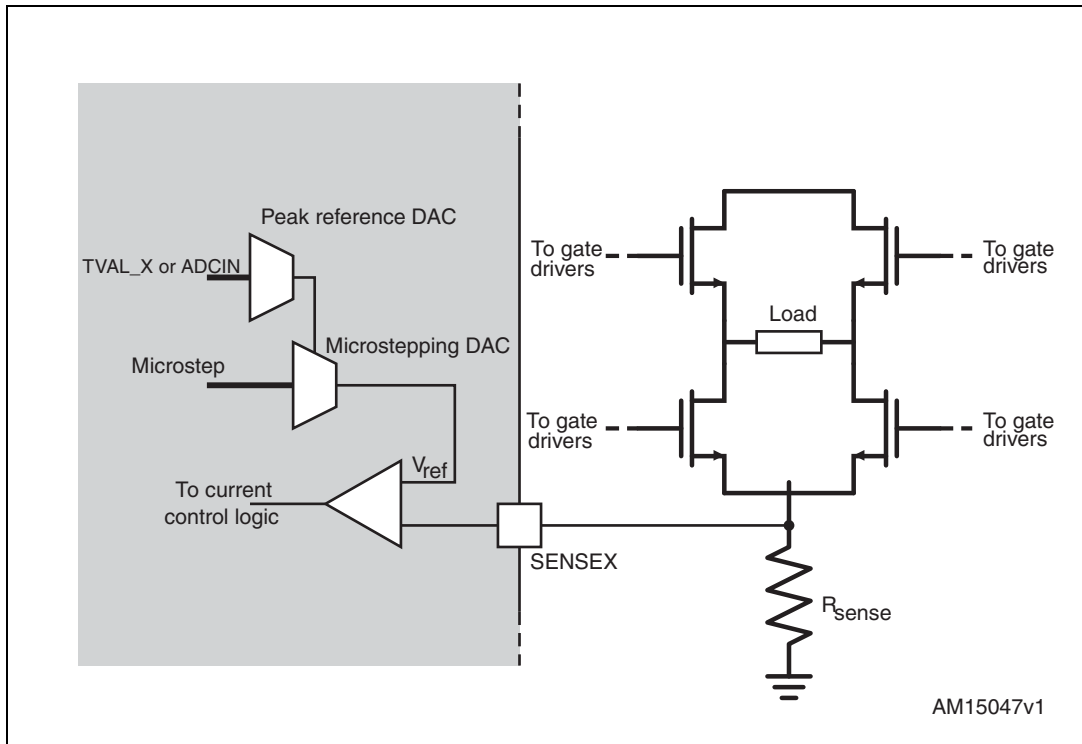

8 Serial interface

The integrated 8-bit serial peripheral interface (SPI) is used for a synchronous serial communication between the host microprocessor (always master) and the L6482 (always slave).

The SPI uses chip select (\overline{CS}), serial clock (CK), serial data input (SDI) and serial data output (SDO) pins. When \overline{CS} is high the device is unselected and the SDO line is inactive (high impedance).

The communication starts when \overline{CS} is forced low. The CK line is used for synchronization of data communication.

All commands and data bytes are shifted into the device through the SDI input, most significant bit first. The SDI is sampled on the rising edges of the CK.

All output data bytes are shifted out of the device through the SDO output, most significant bit first. The SDO is latched on the falling edges of the CK. When a return value from the device is not available, an all zero byte is sent.

After each byte transmission the \overline{CS} input must be raised and be kept high for at least t_{disCS} in order to allow the device to decode the received command and put the return value into the shift register.

All timing requirements are shown in *Figure 23* (see *Section 3* for values).

Multiple devices can be connected in daisy chain configuration, as shown in *Figure 24*.

Figure 23. SPI timings diagram

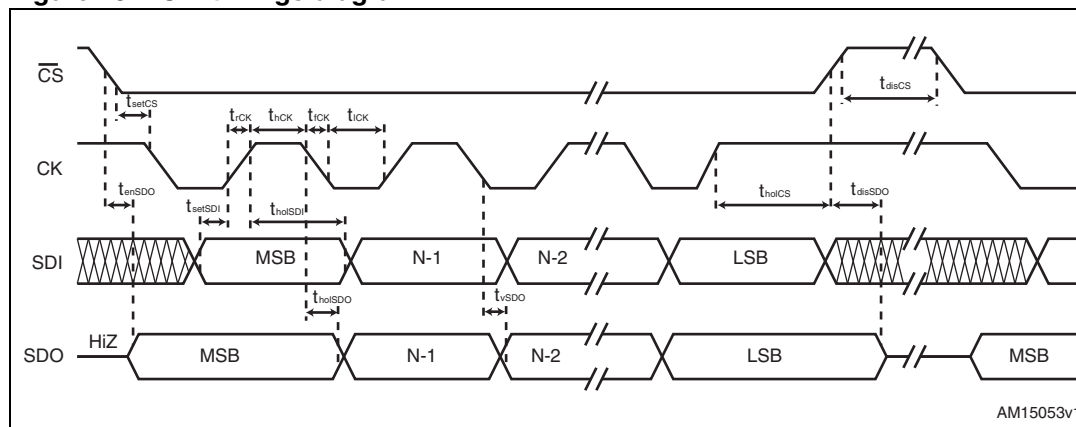
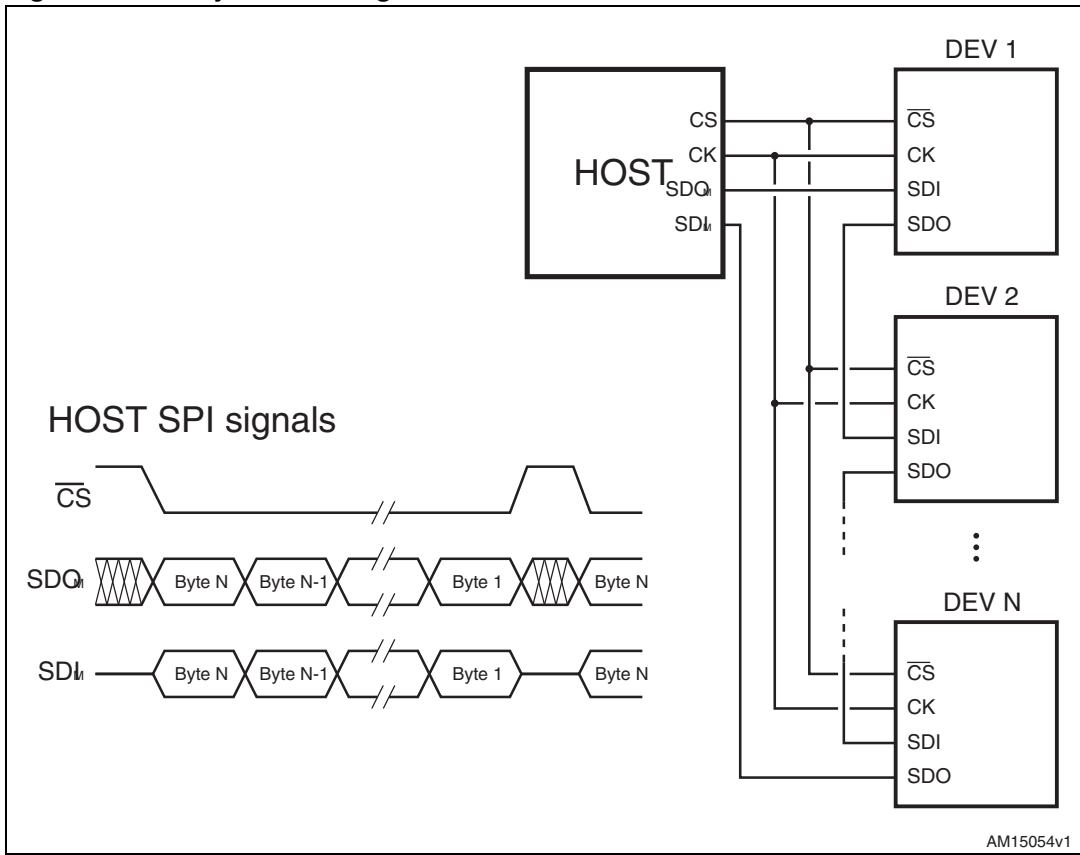

Figure 24. Daisy chain configuration



9 Programming manual

9.1 Register and flag description

[Table 11](#) shows the user registers available (a detailed description can be found in the respective paragraphs):

Table 11. Register map

Address [Hex]	Register name	Register function	Len. [bit]	Reset Hex	Reset value	Remarks (1)
h01	ABS_POS	Current position	22	000000	0	R, WS
h02	EL_POS	Electrical position	9	000	0	R, WS
h03	MARK	Mark position	22	000000	0	R, WR
h04	SPEED	Current speed	20	00000	0 step/tick (0 step/s)	R
h05	ACC	Acceleration	12	08A	125.5e-12 step/tick ² (2008 step/s ²)	R, WS
h06	DEC	Deceleration	12	08A	125.5e-12 step/tick ² (2008 step/s ²)	R, WS
h07	MAX_SPEED	Maximum speed	10	041	248e-6 step/tick (991.8 step/s)	R, WR
h08	MIN_SPEED	Minimum speed	12	000	0 step/tick (0 step/s)	R, WS
h15	FS_SPD	Full-step speed	10	027	150.7e-6 step/tick (602.7 step/s)	R, WR
h09	TVAL_HOLD	Holding reference voltage	7	29	328 mV	R, WR
h0A	TVAL_RUN	Constant speed reference voltage	7	29	328 mV	R, WR
h0B	TVAL_ACC	Acceleration starting reference voltage	7	29	328 mV	R, WR
h0C	TVAL_DEC	Deceleration starting reference voltage	7	29	328 mV	R, WR
h0D	RESERVED	-	16	-	-	-
h0E	T_FAST	Fast decay settings	8	19	1 us / 5 us	R, WH
h0F	TON_MIN	Minimum on-time	8	29	20.5 us	R, WH
h10	TOFF_MIN	Minimum off-time	8	29	20.5 us	R, WH
h11	RESERVED	-	8	-	-	-
h12	ADC_OUT	ADC output	5	XX ⁽²⁾	0	R
h13	OCD_TH	OCD threshold	5	8	281.25 mV	R, WR
h14	RESERVED	-	8	-	-	-
h16	STEP_MODE	Step mode	8	7	16 μsteps, SYNC mode disabled	R, WH
h17	ALARM_EN	Alarms enabled	8	FF	All alarms enabled	R, WS

Table 11. Register map (continued)

Address [Hex]	Register name	Register function	Len. [bit]	Reset Hex	Reset value	Remarks (1)
h18	GATECFG1	Gate driver configuration	11	0	$I_{gate} = 4 \text{ mA}$, $t_{CC} = 125 \text{ ns}$, no boost	R, WH
h19	GATECFG2	Gate driver configuration	8	0	$t_{BLANK} = 125 \text{ ns}$, $t_{DT} = 125 \text{ ns}$	R, WH
h1A	CONFIG	IC configuration	16	2C88	Internal 16 MHz oscillator (OSCOUT@2 MHz), SW event causes HardStop, motor supply voltage compensation disabled, overcurrent shutdown, $V_{CC} = 7.5 \text{ V}$, UVLO threshold low, $t_{SW} = 44 \text{ us}$	R, WH
h1B	STATUS	Status	16	XXXX ⁽²⁾	High impedance state, motor stopped, reverse direction, all fault flags released UVLO/Reset flag set	R

1. R: readable, WH: writable, only when outputs are in high impedance, WS: writable only when motor is stopped, WR: always writable.
2. According to startup conditions.

9.1.1 ABS_POS

The ABS_POS register contains the current motor absolute position in agreement with the selected step mode; the stored value unit is equal to the selected step mode (full, half, quarter, etc.). The value is in 2's complement format and it ranges from -2^{21} to $+2^{21}-1$.

At power-on the register is initialized to "0" (HOME position).

Any attempt to write the register when the motor is running causes the command to be ignored and the NOTPERF_CMD flag to rise ([Section 9.1.21](#)).

9.1.2 EL_POS

The EL_POS register contains the current electrical position of the motor. The two MSbits indicate the current step and the other bits indicate the current microstep (expressed in step/16) within the step.

Table 12. EL_POS register

Bit 8	Bit 7	Bit 6	Bit 5	Bit 4	Bit 3	Bit 2	Bit 1	Bit 0
STEP		MICROSTEP				0	0	0

When the EL_POS register is written by the user, the new electrical position is instantly imposed. When the EL_POS register is written, its value must be masked in order to match

with the step mode selected in the STEP_MODE register in order to avoid a wrong microstep value generation ([Section 9.1.17](#)); otherwise the resulting microstep sequence is incorrect.

Any attempt to write the register when the motor is running causes the command to be ignored and the NOTPERF_CMD flag to rise ([Section 9.1.21](#)).

9.1.3 MARK

The MARK register contains an absolute position called MARK, according to the selected step mode; the stored value unit is equal to the selected step mode (full, half, quarter, etc.). It is in 2's complement format and it ranges from -2^{21} to $+2^{21}-1$.

9.1.4 SPEED

The SPEED register contains the current motor speed, expressed in step/tick (format unsigned fixed point 0.28).

In order to convert the SPEED value in step/s, the following formula can be used:

Equation 1

$$[\text{step/s}] = \frac{\text{SPEED} \cdot 2^{-28}}{\text{tick}}$$

where SPEED is the integer number stored in the register and tick is 250 ns.

The available range is from 0 to 15625 step/s with a resolution of 0.015 step/s.

Note: The range effectively available to the user is limited by the MAX_SPEED parameter.

Any attempt to write the register causes the command to be ignored and the NOTPERF_CMD flag to rise ([Section 9.1.21](#)).

9.1.5 ACC

The ACC register contains the speed profile acceleration expressed in step/tick² (format unsigned fixed point 0.40).

In order to convert the ACC value in step/s², the following formula can be used:

Equation 2

$$[\text{step/s}^2] = \frac{\text{ACC} \cdot 2^{-40}}{\text{tick}^2}$$

where ACC is the integer number stored in the register and tick is 250 ns.

The available range is from 14.55 to 59590 step/s² with a resolution of 14.55 step/s².

When the ACC value is set to 0xFFFF, the device works in infinite acceleration mode.

Any attempt to write to the register when the motor is running causes the command to be ignored and the NOTPERF_CMD flag to rise ([Section 9.1.21](#)).

9.1.6 DEC

The DEC register contains the speed profile deceleration expressed in step/tick² (format unsigned fixed point 0.40).

In order to convert the DEC value in step/s², the following formula can be used:

Equation 3

$$[\text{step/s}^2] = \frac{\text{DEC} \cdot 2^{-40}}{\text{tick}^2}$$

where DEC is the integer number stored in the register and tick is 250 ns.

The available range is from 14.55 to 59590 step/s² with a resolution of 14.55 step/s².

When the device is working in infinite acceleration mode this value is ignored.

Any attempt to write the register when the motor is running causes the command to be ignored and the NOTPERF_CMD flag to rise ([Section 9.1.21](#)).

9.1.7 MAX_SPEED

The MAX_SPEED register contains the speed profile maximum speed expressed in step/tick (format unsigned fixed point 0.18).

In order to convert it in step/s, the following formula can be used:

Equation 4

$$[\text{step/s}] = \frac{\text{MAX_SPEED} \cdot 2^{-18}}{\text{tick}}$$

where MAX_SPEED is the integer number stored in the register and tick is 250 ns.

The available range is from 15.25 to 15610 step/s with a resolution of 15.25 step/s.

9.1.8 MIN_SPEED

The MIN_SPEED register contains the following parameters:

Table 13. MIN_SPEED register

Bit 12	Bit 11	Bit 10	Bit 9	Bit 8	Bit 7	Bit 6	Bit 5	Bit 4	Bit 3	Bit 2	Bit 1	Bit 0
0	MIN_SPEED											

The MIN_SPEED parameter contains the speed profile minimum speed. Its value is expressed in step/tick and to convert it in step/s the following formula can be used:

Equation 5

$$[\text{step/s}] = \frac{\text{MIN_SPEED} \cdot 2^{-24}}{\text{tick}}$$

where MIN_SPEED is the integer number stored in the register and tick is the ramp 250 ns.

The available range is from 0 to 976.3 step/s with a resolution of 0.238 step/s.

Any attempt to write the register when the motor is running causes the NOTPERF_CMD flag to rise.

9.1.9 FS_SPD

The FS_SPD register contains the following parameters:

Table 14. FS_SPD register

Bit 11	Bit 10	Bit 9	Bit 8	Bit 7	Bit 6	Bit 5	Bit 4	Bit 3	Bit 2	Bit 1	Bit 0
BOOST_MODE	FS_SPD										

The FS_SPD threshold speed value over which the step mode is automatically switched to full-step two-phase on. Its value is expressed in step/tick (format unsigned fixed point 0.18) and to convert it in step/s the following formula can be used:

Equation 6

$$[\text{step/s}] = \frac{(\text{FS_SPD} + 0.5) \cdot 2^{-18}}{\text{tick}}$$

If FS_SPD value is set to hFF (max.) the system always works in Microstepping mode (SPEED must go over the threshold to switch to Full-step mode). Setting FS_SPD to zero does not have the same effect as setting the step mode to full-step two-phase on: the zero FS_SPD value is equivalent to a speed threshold of about 7.63 step/s.

The available range is from 7.63 to 15625 step/s with a resolution of 15.25 step/s.

The BOOST_MODE bit sets the amplitude of the voltage squarewave during the full-step operation (see [Section 6.4.1](#)).

9.1.10 TVAL_HOLD, TVAL_RUN, TVAL_ACC and TVAL_DEC

The TVAL_HOLD register contains the reference voltage that is assigned to the torque regulation DAC when the motor is stopped.

The TVAL_RUN register contains the reference voltage that is assigned to the torque regulation DAC when the motor is running at constant speed.

The TVAL_ACC register contains the reference voltage that is assigned to the torque regulation DAC during acceleration.

The TVAL_DEC register contains the reference voltage that is assigned to the torque regulation DAC during deceleration.

The available range is from 7.8 mV to 1 V with a resolution of 7.8 mV, as shown in [Table 15](#).

Table 15. Torque regulation by TVAL_HOLD, TVAL_ACC, TVAL_DEC and TVAL_RUN registers

TVAL_X [6..0]							Peak reference voltage
0	0	0	0	0	0	0	7.8 mV
0	0	0	0	0	0	1	15.6 mV
⋮	⋮	⋮	⋮	⋮	⋮	⋮	⋮
1	1	1	1	1	1	0	992.2 mV
1	1	1	1	1	1	1	1 V

9.1.11 T_FAST

The T_FAST register contains the maximum fast decay time (TOFF_FAST) and the maximum fall step time (FALL_STEP) used by the current control system ([Section 7.2](#) and [Section 7.3](#) for details):

Table 16. FS_SPD register

Bit 7	Bit 6	Bit 5	Bit 4	Bit 3	Bit 2	Bit 1	Bit 0
TOFF_FAST				FAST_STEP			

The available range for both parameters is from 2 μs to 32 μs.

Table 17. Maximum fast decay times

TOFF_FAST [3..0] FAST_STEP[3..0]				Fast decay time
0	0	0	0	2 μs
0	0	0	1	4 μs
⋮	⋮	⋮	⋮	⋮
1	1	1	0	28 μs
1	1	1	1	32 μs

Any attempt to write to the register when the motor is running causes the command to be ignored and NOTPERF_CMD to rise ([Section 9.1.21](#)).

9.1.12 TON_MIN

This parameter is used by the current control system when current mode operation is selected.

The TON_MIN register contains the minimum on-time value used by the current control system (see [Section 7.2](#)).

The available range for both parameters is from 0.5 μs to 64 μs.

Table 18. Minimum on-time

TON MIN [6..0]							Time
0	0	0	0	0	0	0	0.5 μ s
0	0	0	0	0	0	1	1 μ s
⋮	⋮	⋮	⋮	⋮	⋮	⋮	⋮
1	1	1	1	1	1	0	63.5 μ s
1	1	1	1	1	1	1	64 μ s

Any attempt to write to the register when the motor is running causes the command to be ignored and the NOTPERF_CMD to rise (see [Section 9.1.21](#)).

9.1.13 TOFF_MIN

This parameter is used by the current control system when current mode operation is selected.

The TOFF_MIN register contains the minimum off-time value used by the current control system (see [Section 7.1](#) for details).

The available range for both parameters is from 0.5 μ s to 64 μ s.

Table 19. Minimum off-time

TOFF MIN [6..0]							Time
0	0	0	0	0	0	0	0.5 μ s
0	0	0	0	0	0	1	1 μ s
⋮	⋮	⋮	⋮	⋮	⋮	⋮	⋮
1	1	1	1	1	1	0	63.5 μ s
1	1	1	1	1	1	1	64 μ s

Any attempt to write to the register when the motor is running causes the command to be ignored and NOTPERF_CMD to rise (see [Section 9.1.21](#)).

9.1.14 ADC_OUT

The ADC_OUT register contains the result of the analog-to-digital conversion of the ADCIN pin voltage.

Any attempt to write to the register causes the command to be ignored and the NOTPERF_CMD flag to rise (see [Section 9.1.21](#)).

Table 20. ADC_OUT value and torque regulation feature

VADCIN/ VREG	ADC_OUT [4..0]					Reference voltage
0	0	0	0	0	0	31.25 mV
1/32	0	0	0	0	1	62.5 mV
⋮	⋮	⋮	⋮	⋮	⋮	⋮
30/32	1	1	1	1	0	968.8 mV
31/32	1	1	1	1	1	1 V

9.1.15 OCD_TH

The OCD_TH register contains the overcurrent threshold value (see [Section 6.9](#) for details). The available range is from 31.25 mV to 1 V, steps of 31.25 mV, as shown in [Table 21](#).

Table 21. Overcurrent detection threshold

OCD_TH [4..0]					Overcurrent detection threshold
0	0	0	0	0	31.25 mV
0	0	0	0	1	62.5 mV
⋮	⋮	⋮	⋮	⋮	⋮
1	1	1	1	0	968.8 mV
1	1	1	1	1	1 V

9.1.16 STEP_MODE

The STEP_MODE register has the following structure:

Table 22. STEP_MODE register

Bit 7	Bit 6	Bit 5	Bit 4	Bit 3	Bit 2	Bit 1	Bit 0
SYNC_EN	SYNC_SEL			1 ⁽¹⁾	STEP_SEL		

1. When the register is written this bit must be set to 1.

The STEP_SEL parameter selects one of five possible stepping modes:

Table 23. Step mode selection

STEP_SEL[2..0]			Step mode
0	0	0	Full-step
0	0	1	Half-step
0	1	0	1/4 microstep
0	1	1	1/8 microstep
1	X	X	1/16 microstep

Every time the step mode is changed, the electrical position (i.e. the point of microstepping sinewave that is generated) is reset to the first microstep.

Warning: Every time STEP_SEL is changed, the value in the ABS_POS register loses meaning and should be reset.

Any attempt to write the register when the motor is running causes the command to be ignored and the NOTPERF_CMD flag to rise (see [Section 9.1.21](#)).

When the SYNC_EN bit is set low, the $\overline{\text{BUSY}}/\text{SYNC}$ output is forced low during the command execution, otherwise, when the SYNC_EN bit is set high, the $\overline{\text{BUSY}}/\text{SYNC}$ output provides a clock signal according to the SYNC_SEL parameter.

Table 24. SYNC output frequency

STEP_SEL (f_{FS} is the full-step frequency)									
	000	001	010	011	100	101	110	111	
SYNC_SEL	000	$f_{FS}/2$	$f_{FS}/2$	$f_{FS}/2$	$f_{FS}/2$	$f_{FS}/2$	$f_{FS}/2$	$f_{FS}/2$	$f_{FS}/2$
	001	NA	f_{FS}	f_{FS}	f_{FS}	f_{FS}	f_{FS}	f_{FS}	f_{FS}
	010	NA	NA	$2 \cdot f_{FS}$	$2 \cdot f_{FS}$	$2 \cdot f_{FS}$	$2 \cdot f_{FS}$	$2 \cdot f_{FS}$	$2 \cdot f_{FS}$
	011	NA	NA	NA	$4 \cdot f_{FS}$	$4 \cdot f_{FS}$	$4 \cdot f_{FS}$	$4 \cdot f_{FS}$	$4 \cdot f_{FS}$
	100	NA	NA	NA	NA	$8 \cdot f_{FS}$	$8 \cdot f_{FS}$	$8 \cdot f_{FS}$	$8 \cdot f_{FS}$
	101	NA	NA	NA	NA	NA	NA	NA	NA
	110	NA	NA	NA	NA	NA	NA	NA	NA
	111	NA	NA	NA	NA	NA	NA	NA	NA

The synchronization signal is obtained starting from the electrical position information (EL_POS register), according to [Table 25](#):

Table 25. SYNC signal source

SYNC_SEL[2..0]			Source
0	0	0	EL_POS[7]
0	0	1	EL_POS[6]
0	1	0	EL_POS[5]
0	1	1	EL_POS[4]
1	0	0	EL_POS[3]
1	0	1	UNUSED ⁽¹⁾
1	1	0	UNUSED ⁽¹⁾
1	1	1	UNUSED ⁽¹⁾

1. When this value is selected, the BUSY output is forced low.

9.1.17 ALARM_EN

The ALARM_EN register allows the selection of which alarm signals are used to generate the FLAG output. If the respective bit of the ALARM_EN register is set high, the alarm condition forces the FLAG pin output down.

Table 26. ALARM_EN register

ALARM_EN bit	Alarm condition
0 (LSB)	Overcurrent
1	Thermal shutdown

Table 26. ALARM_EN register (continued)

ALARM_EN bit	Alarm condition
2	Thermal warning
3	UVLO
4	ADC UVLO
5	Unused
6	Switch turn-on event
7 (MSB)	Command error

9.1.18 GATECFG1

The GATECFG1 register has the following structure:

Table 27. GATECFG1 register

Bit 15	Bit 14	Bit 13	Bit 12	Bit 11	Bit 10	Bit 9	Bit 8
				WD_EN	TBOOST		
Bit 7	Bit 6	Bit 5	Bit 4	Bit 3	Bit 2	Bit 1	Bit 0
IGATE			TCC				

The IGATE parameter selects the sink/source current used by gate driving circuitry to charge/discharge the respective gate during commutations. Seven possible values ranging from 4 mA to 96 mA are available, as shown in [Table 28](#).

Table 28. IGATE parameter

IGATE [2..0]			Gate current [mA]
0	0	0	4
0	0	1	4
0	1	0	8
0	1	1	16
1	0	0	24
1	0	1	32
1	1	0	64
1	1	1	96

The TCC parameter defines the duration of constant current phase during gate turn-on and turn-off sequences ([Section 6.15](#)).

Table 29. TCC parameter

TCC [4..0]					Constant current time [ns]
0	0	0	0	0	125
0	0	0	0	1	250
↓	↓	↓	↓	↓	↓
1	1	1	0	0	3625
1	1	1	0	1	3750
1	1	1	1	0	3750
1	1	1	1	1	3750

The TBOOST parameter defines the duration of the overboost phase during gate turn-off ([Section 6.15](#)).

Table 30. TBOOST parameter

TBOOST			Turn-off boost time
[2..0]			[ns]
0	0	0	0
0	0	1	62.5 ⁽¹⁾ /83.3 ⁽²⁾ /125 ⁽³⁾
0	1	0	125
0	1	1	250
1	0	0	375
1	0	1	500
1	1	0	750
1	1	1	1000

1. Clock frequency equal to 16 MHz or 32 MHz.
2. Clock frequency equal to 24 MHz.
3. Clock frequency equal to 8 MHz.

The WD_EN bit enables the clock source monitoring ([Section 6.8.2](#)).

9.1.19 GATECFG2

The GATECFG2 register has the following structure:

Table 31. GATECFG2 register (voltage mode)

Bit 7	Bit 6	Bit 5	Bit 4	Bit 3	Bit 2	Bit 1	Bit 0
TBLANK			TDT				

The TCC parameter defines the deadtime duration between the gate turn-off and the opposite gate turn-on sequences ([Section 6.16](#)).

Table 32. TDT parameter

TDT [4..0]					Deadtime [ns]
0	0	0	0	0	125
0	0	0	0	1	250
↓	↓	↓	↓	↓	↓
1	1	1	1	0	3875
1	1	1	1	1	4000

The TBLANK parameter defines the duration of the blanking of the current sensing comparators (stall detection and overcurrent) after each commutation ([Section 6.16](#)).

Table 33. TBLANK parameters

TBLANK [2..0]			Blanking time [ns]
0	0	0	125
0	0	1	250
↓	↓	↓	↓
1	1	0	875
1	1	1	1000

9.1.20 CONFIG

The CONFIG register has the following structure:

Table 34. CONFIG register

Bit 15	Bit 14	Bit 13	Bit 12	Bit 11	Bit 10	Bit 9	Bit 8
PRED_E	TSW					VCCVAL	UVLOVAL
Bit 7	Bit 6	Bit 5	Bit 4	Bit 3	Bit 2	Bit 1	Bit 0
OC_SD	RESERVED	EN_TQREG	SW_MOD E	EXT_CLK	OSC_SEL		

The OSC_SEL and EXT_CLK bits set the system clock source:

Table 35. Oscillator management

EXT_CLK	OSC_SEL[2..0]			Clock source	OSCIN	OSCOUT
0	0	0	0	Internal oscillator: 16 MHz	Unused	Unused
0	0	0	1			
0	0	1	0			
0	0	1	1			
1	0	0	0	Internal oscillator: 16 MHz	Unused	Supplies a 2-MHz clock
1	0	0	1	Internal oscillator: 16 MHz	Unused	Supplies a 4-MHz clock
1	0	1	0	Internal oscillator: 16 MHz	Unused	Supplies an 8-MHz clock
1	0	1	1	Internal oscillator: 16 MHz	Unused	Supplies a 16-MHz clock
0	1	0	0	External crystal or resonator: 8 MHz	Crystal/resonator driving	Crystal/resonator driving
0	1	0	1	External crystal or resonator: 16 MHz	Crystal/resonator driving	Crystal/resonator driving
0	1	1	0	External crystal or resonator: 24 MHz	Crystal/resonator driving	Crystal/resonator driving
0	1	1	1	External crystal or resonator: 32 MHz	Crystal/resonator driving	Crystal/resonator driving
1	1	0	0	Ext. clock source: 8 MHz (crystal/resonator driver disabled)	Clock source	Supplies inverted OSCIN signal
1	1	0	1	Ext. clock source: 16 MHz (crystal/resonator driver disabled)	Clock source	Supplies inverted OSCIN signal
1	1	1	0	Ext. clock source: 24 MHz (crystal/resonator driver disabled)	Clock source	Supplies inverted OSCIN signal
1	1	1	1	Ext. clock source: 32 MHz (crystal/resonator driver disabled)	Clock source	Supplies inverted OSCIN signal

The SW_MODE bit sets the external switch to act as HardStop interrupt or not:

Table 36. External switch HardStop interrupt mode

SW_MODE	Switch mode
0	HardStop interrupt
1	User disposal

The OC_SD bit sets if an overcurrent event causes or not the bridges to turn off; the OCD flag in the status register is forced low anyway:

Table 37. Overcurrent event

OC_SD	Overcurrent event
1	Bridges shutdown
0	Bridges do not shutdown

The VCCVAL bit sets the internal V_{CC} regulator output voltage.

Table 38. Programmable V_{CC} regulator output voltage

VCCVAL	V_{CC} voltage
0	7.5 V
1	15 V

The UVLOVAL bit sets the UVLO protection thresholds.

Table 39. Programmable UVLO thresholds

UVLOVAL	V_{CCthOn}	$V_{CCthOff}$	$\Delta V_{BOOTthOn}$	$\Delta V_{BOOTthOff}$
0	6.9 V	6.3 V	6 V	5.5 V
1	10.4 V	10 V	9.2 V	8.8 V

The EN_TQREG bit sets if the torque regulation is performed through ADCIN voltage (external) or the TVAL_HOLD, TVAL_ACC, TVAL_DEC and TVAL_RUN registers (internal).

Table 40. External torque regulation enable

EN_TQREG	External torque regulation
0	Disabled
1	Enabled

The TSW parameter is used by the current control system and it sets the target switching period.

Table 41. Switching period

TSW [4..0]					Switching period
0	0	0	0	0	4 μ s (250 kHz)
0	0	0	0	1	4 μ s (250 kHz)
0	0	0	1	0	8 μ s (125 kHz)

Table 41. Switching period (continued)

TSW [4..0]					Switching period
⋮	⋮	⋮	⋮	⋮	⋮
1	1	1	1	1	124 μs (8 kHz)

Any attempt to write the CONFIG register when the motor is running causes the command to be ignored and the NOTPERF_CMD flag to rise (see [Section 9.1.21](#)).

The EN_PRED bit sets if the predictive current control method is enabled or not.

Table 42. Motor supply voltage compensation enable

EN_PRED	Predictive current control
0	Disabled
1	Enabled

Any attempt to write the CONFIG register when the motor is running causes the command to be ignored and the NOTPERF_CMD flag to rise ([Section 9.1.20](#)).

9.1.21 STATUS

The STATUS register has the following structure:

Table 43. STATUS register

Bit 15	Bit 14	Bit 13	Bit 12	Bit 11	Bit 10	Bit 9	Bit 8
Unused	Unused	OCD	TH_SD		UVLO_AD C	UVLO	STCK_MOD
Bit 7	Bit 6	Bit 5	Bit 4	Bit 3	Bit 2	Bit 1	Bit 0
NOTPERF_CM D	MOT_STATUS		DIR	SW_EV N	SW_F	BUSY	HiZ

When the HiZ flag is high it indicates that the bridges are in high impedance state. Any motion command causes the device to exit from High Z state (HardStop and SoftStop included), unless error flags forcing a High Z state are active.

The UVLO flag is active low and is set by an undervoltage lockout or reset events (power-up included).

The UVLO_ADC flag is active low and indicates an ADC undervoltage event.

The OCD flag is active low and indicates an overcurrent detection event.

The CMD_ERROR flag is active high and indicates that the command received by SPI can't be performed or does not exist at all.

The SW_F reports the SW input status (low for open and high for closed).

The SW_EVN flag is active high and indicates a switch turn-on event (SW input falling edge).

TH_STATUS bits indicate the current device thermal status ([Section 6.12](#)):

Table 44. STATUS register TH_STATUS bits

TH_STATUS		Status
0	0	Normal
0	1	Warning
1	0	Bridge shutdown
1	1	Device shutdown

UVLO, UVLO_ADC, OCD, CMD_ERROR, SW_EVN and TH_STATUS bits are latched: when the respective conditions make them active (low or high) they remain in that state until a GetStatus command is sent to the IC.

The BUSY bit reflects the BUSY pin status. The BUSY flag is low when a constant speed, positioning or motion command is under execution and is released (high) after the command has been completed.

The STCK_MOD bit is an active high flag indicating that the device is working in Step-clock mode. In this case the step-clock signal should be provided through the STCK input pin.

The DIR bit indicates the current motor direction:

Table 45. STATUS register DIR bit

DIR	Motor direction
1	Forward
0	Reverse

MOT_STATUS indicates the current motor status:

Table 46. STATUS register MOT_STATE bits

MOT_STATUS		Motor status
0	0	Stopped
0	1	Acceleration
1	0	Deceleration
1	1	Constant speed

Any attempt to write to the register causes the command to be ignored and the NOTPERF_CMD to rise ([Section 9.1.21](#)).

9.2 Application commands

The command summary is given in [Table 47](#).

Table 47. Application commands

Command Mnemonic	Command binary code					Action
	[7..5]	[4]	[3]	[2..1]	[0]	
NOP	000	0	0	00	0	Nothing
SetParam(PARAM,VALUE)	000	[PARAM]				Writes VALUE in PARAM register
GetParam(PARAM)	001	[PARAM]				Returns the stored value in PARAM register
Run(DIR,SPD)	010	1	0	00	DIR	Sets the target speed and the motor direction
StepClock(DIR)	010	1	1	00	DIR	Puts the device in Step-clock mode and imposes DIR direction
Move(DIR,N_STEP)	010	0	0	00	DIR	Makes N_STEP (micro)steps in DIR direction (not performable when motor is running)
GoTo(ABS_POS)	011	0	0	00	0	Brings motor in ABS_POS position (minimum path)
GoTo_DIR(DIR,ABS_POS)	011	0	1	00	DIR	Brings motor in ABS_POS position forcing DIR direction
GoUntil(ACT,DIR,SPD)	100	0	ACT	01	DIR	Performs a motion in DIR direction with speed SPD until SW is closed, the ACT action is executed then a SoftStop takes place
ReleaseSW(ACT, DIR)	100	1	ACT	01	DIR	Performs a motion in DIR direction at minimum speed until the SW is released (open), the ACT action is executed then a HardStop takes place
GoHome	011	1	0	00	0	Brings the motor in HOME position
GoMark	011	1	1	00	0	Brings the motor in MARK position
ResetPos	110	1	1	00	0	Resets the ABS_POS register (sets HOME position)
ResetDevice	110	0	0	00	0	Device is reset to power-up conditions
SoftStop	101	1	0	00	0	Stops motor with a deceleration phase
HardStop	101	1	1	00	0	Stops motor immediately
SoftHiZ	101	0	0	00	0	Puts the bridges in high impedance status after a deceleration phase
HardHiZ	101	0	1	00	0	Puts the bridges in high impedance status immediately
GetStatus	110	1	0	00	0	Returns the status register value
RESERVED	111	0	1	01	1	RESERVED COMMAND
RESERVED	111	1	1	00	0	RESERVED COMMAND

9.2.1 Command management

The host microcontroller can control motor motion and configure the L6482 through a complete set of commands.

All commands are composed by a single byte. After the command byte, some bytes of arguments should be needed (see [Figure 25](#)). Argument length can vary from 1 to 3 bytes.

Figure 25. Command with 3-byte argument

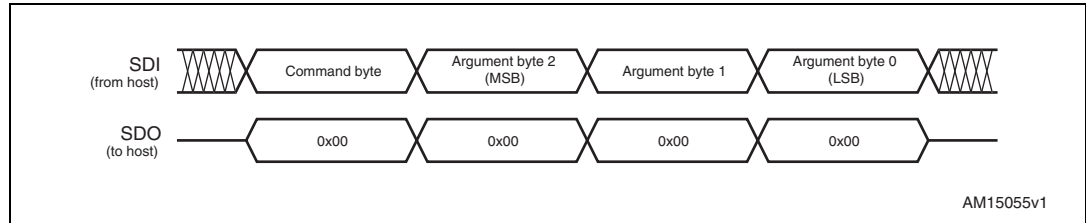

By default, the device returns an all zero response for any received byte, the only exceptions are GetParam and GetStatus commands. When one of these commands is received, the following response bytes represent the related register value (see [Figure 26](#)). Response length can vary from 1 to 3 bytes.

Figure 26. Command with 3-byte response

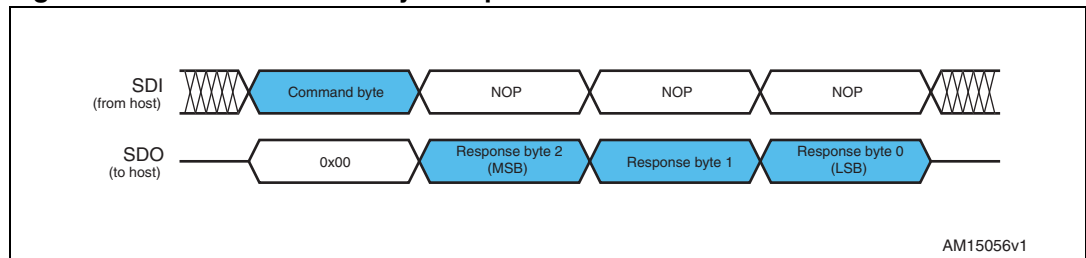

During response transmission, new commands can be sent. If a command requiring a response is sent before the previous response is completed, the response transmission is aborted and the new response is loaded into the output communication buffer (see [Figure 27](#)).

Figure 27. Command response aborted

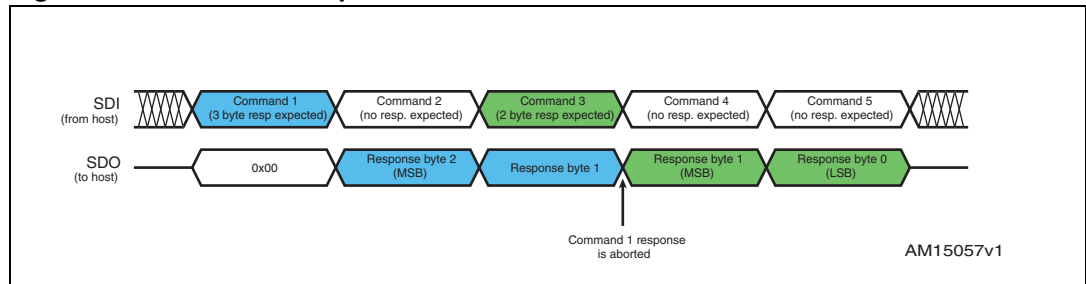

When a byte that does not correspond to a command is sent to the IC it is ignored and the WRONG_CMD flag in the STATUS register is raised (see [Section 9.1.21](#)).

9.2.2 Nop

Table 48. Nop command structure

Bit 7	Bit 6	Bit 5	Bit 4	Bit 3	Bit 2	Bit 1	Bit 0	
0	0	0	0	0	0	0	0	From host

Nothing is performed.

9.2.3 SetParam (PARAM, VALUE)

Table 49. SetParam command structure

Bit 7	Bit 6	Bit 5	Bit 4	Bit 3	Bit 2	Bit 1	Bit 0	
0	0	0	PARAM				From host	
VALUE Byte 2 (if needed)								
VALUE Byte 1 (if needed)								
VALUE Byte 0								

The SetParam command sets the PARAM register value equal to VALUE; PARAM is the respective register address listed in [Table 11](#).

The command should be followed by the new register VALUE (most significant byte first). The number of bytes composing the VALUE argument depends on the length of the target register (see [Table 11](#)).

Some registers cannot be written (see [Table 11](#)); any attempt to write one of those registers causes the command to be ignored and the WRONG_CMD flag to rise at the end of the command byte, as if an unknown command code were sent (see [Section 9.1.21](#)).

Some registers can only be written in particular conditions (see [Table 11](#)); any attempt to write one of those registers when the conditions are not satisfied causes the command to be ignored and the NOTPERF_CMD flag to rise at the end of the last argument byte (see [Section 9.1.21](#)).

Any attempt to set an inexistent register (wrong address value) causes the command to be ignored and the WRONG_CMD flag to rise at the end of the command byte as if an unknown command code were sent.

9.2.4 GetParam (PARAM)

Table 50. GetParam command structure

Bit 7	Bit 6	Bit 5	Bit 4	Bit 3	Bit 2	Bit 1	Bit 0	
0	0	1	PARAM				from host	
ANS Byte 2 (if needed)						to host		
ANS Byte 1 (if needed)						to host		
ANS Byte 0						to host		

This command reads the current PARAM register value; PARAM is the respective register address listed in [Table 11](#).

The command response is the current value of the register (most significant byte first). The number of bytes composing the command response depends on the length of the target register (see [Table 11](#)).

The returned value is the register one at the moment of GetParam command decoding. If register values change after this moment, the response is not updated accordingly.

All registers can be read anytime.

Any attempt to read an inexistent register (wrong address value) causes the command to be ignored and the WRONG_CMD flag to rise at the end of the command byte as if an unknown command code were sent.

9.2.5 Run (DIR, SPD)

Table 51. Run command structure

Bit 7	Bit 6	Bit 5	Bit 4	Bit 3	Bit 2	Bit 1	Bit 0	
0	1	0	1	0	0	0	DIR	from host
X	X	X	X	SPD (Byte 2)				from host
SPD (Byte 1)								from host
SPD (Byte 0)								from host

The Run command produces a motion at SPD speed; the direction is selected by the DIR bit: '1' forward or '0' reverse. The SPD value is expressed in step/tick (format unsigned fixed point 0.28) that is the same format as the SPEED register ([Section 9.1.4](#)).

Note: The SPD value should be lower than MAX_SPEED and greater than MIN_SPEED, otherwise the Run command is executed at MAX_SPEED or MIN_SPEED respectively.

This command keeps the BUSY flag low until the target speed is reached.

This command can be given anytime and is immediately executed.

9.2.6 StepClock (DIR)

Table 52. StepClock command structure

Bit 7	Bit 6	Bit 5	Bit 4	Bit 3	Bit 2	Bit 1	Bit 0	
0	1	0	1	1	0	0	DIR	from host

The StepClock command switches the device in Step-clock mode ([Section 6.7.5](#)) and imposes the forward (DIR = '1') or reverse (DIR = '0') direction.

When the device is in Step-clock mode, the SCK_MOD flag in the STATUS register is raised and the motor is always considered stopped ([Section 6.7.5](#) and [9.1.21](#)).

The device exits Step-clock mode when a constant speed, absolute positioning or motion command is sent through SPI. Motion direction is imposed by the respective StepClock

command argument and can be changed by a new StepClock command without exiting Step-clock mode.

Events that cause bridges to be forced into high impedance state (overtemperature, overcurrent, etc.) do not cause the device to leave Step-clock mode.

The StepClock command does not force the BUSY flag low. This command can only be given when the motor is stopped. If a motion is in progress, the motor should be stopped and it is then possible to send a StepClock command.

Any attempt to perform a StepClock command when the motor is running causes the command to be ignored and the NOTPERF_CMD flag to rise ([Section 9.1.21](#)).

9.2.7 Move (DIR, N_STEP)

Table 53. Move command structure

Bit 7	Bit 6	Bit 5	Bit 4	Bit 3	Bit 2	Bit 1	Bit 0	
0	1	0	0	0	0	0	DIR	from host
X	X	N_STEP (Byte 2)						from host
N_STEP (Byte 1)								from host
N_STEP (Byte 0)								from host

The move command produces a motion of N_STEP microsteps; the direction is selected by the DIR bit ('1' forward or '0' reverse).

The N_STEP value is always in agreement with the selected step mode; the parameter value unit is equal to the selected step mode (full, half, quarter, etc.).

This command keeps the BUSY flag low until the target number of steps is performed. This command can only be performed when the motor is stopped. If a motion is in progress the motor must be stopped and it is then possible to perform a move command.

Any attempt to perform a move command when the motor is running causes the command to be ignored and the NOTPERF_CMD flag to rise ([Section 9.1.21](#)).

9.2.8 GoTo (ABS_POS)

Table 54. GoTo command structure

Bit 7	Bit 6	Bit 5	Bit 4	Bit 3	Bit 2	Bit 1	Bit 0	
0	1	1	0	0	0	0	0	from host
X	X	ABS_POS (Byte 2)						from host
ABS_POS (Byte 1)								from host
ABS_POS (Byte 0)								from host

The GoTo command produces a motion to the ABS_POS absolute position through the shortest path. The ABS_POS value is always in agreement with the selected step mode; the parameter value unit is equal to the selected step mode (full, half, quarter, etc.).

The GoTo command keeps the BUSY flag low until the target position is reached.

This command can be given only when the previous motion command has been completed (BUSY flag released).

Any attempt to perform a GoTo command when a previous command is under execution (BUSY low) causes the command to be ignored and the NOTPERF_CMD flag to rise ([Section 9.1.21](#)).

9.2.9 GoTo_DIR (DIR, ABS_POS)

Table 55. GoTo_DIR command structure

Bit 7	Bit 6	Bit 5	Bit 4	Bit 3	Bit 2	Bit 1	Bit 0	
0	1	1	0	1	0	0	DIR	from host
X	X	ABS_POS (Byte 2)						from host
							ABS_POS (Byte 1)	from host
							ABS_POS (Byte 0)	from host

The GoTo_DIR command produces a motion to the ABS_POS absolute position imposing a forward (DIR = '1') or a reverse (DIR = '0') rotation. The ABS_POS value is always in agreement with the selected step mode; the parameter value unit is equal to the selected step mode (full, half, quarter, etc.).

The GoTo_DIR command keeps the BUSY flag low until the target speed is reached. This command can be given only when the previous motion command has been completed (BUSY flag released).

Any attempt to perform a GoTo_DIR command when a previous command is under execution (BUSY low) causes the command to be ignored and the NOTPERF_CMD flag to rise ([Section 9.1.21](#)).

9.2.10 GoUntil (ACT, DIR, SPD)

Table 56. GoUntil command structure

Bit 7	Bit 6	Bit 5	Bit 4	Bit 3	Bit 2	Bit 1	Bit 0	
1	0	0	0	ACT	0	1	DIR	from host
X	X	X	X	SPD (Byte 2)				from host
							SPD (Byte 1)	from host
							SPD (Byte 0)	from host

The GoUntil command produces a motion at SPD speed imposing a forward (DIR = '1') or a reverse (DIR = '0') direction. When an external switch turn-on event occurs ([Section 6.14](#)), the ABS_POS register is reset (if ACT = '0') or the ABS_POS register value is copied into the MARK register (if ACT = '1'); the system then performs a SoftStop command.

The SPD value is expressed in step/tick (format unsigned fixed point 0.28) that is the same format as the SPEED register ([Section 9.1.4](#)).

The SPD value should be lower than MAX_SPEED and greater than MIN_SPEED, otherwise the target speed is imposed at MAX_SPEED or MIN_SPEED respectively.

If the SW_MODE bit of the CONFIG register is set low, the external switch turn-on event causes a HardStop interrupt instead of the SoftStop one ([Section 6.14](#) and [Section 9.1.20](#)).

This command keeps the BUSY flag low until the switch turn-on event occurs and the motor is stopped. This command can be given anytime and is immediately executed.

9.2.11 ReleaseSW (ACT, DIR)

Table 57. ReleaseSW command structure

Bit 7	Bit 6	Bit 5	Bit 4	Bit 3	Bit 2	Bit 1	Bit 0	
1	0	0	1	ACT	0	1	DIR	from host

The ReleaseSW command produces a motion at minimum speed imposing a forward (DIR = '1') or reverse (DIR = '0') rotation. When SW is released (opened) the ABS_POS register is reset (ACT = '0') or the ABS_POS register value is copied into the MARK register (ACT = '1'); the system then performs a HardStop command.

Note that, resetting the ABS_POS register is equivalent to setting the HOME position.

If the minimum speed value is less than 5 step/s or low speed optimization is enabled, the motion is performed at 5 step/s.

The ReleaseSW command keeps the BUSY flag low until the switch input is released and the motor is stopped.

9.2.12 GoHome

Table 58. GoHome command structure

Bit 7	Bit 6	Bit 5	Bit 4	Bit 3	Bit 2	Bit 1	Bit 0	
0	1	1	1	0	0	0	0	from host

The GoHome command produces a motion to the HOME position (zero position) via the shortest path.

Note that, this command is equivalent to the “GoTo(0...0)” command. If a motor direction is mandatory, the GoTo_DIR command must be used ([Section 9.2.9](#)).

The GoHome command keeps the BUSY flag low until the home position is reached. This command can be given only when the previous motion command has been completed. Any attempt to perform a GoHome command when a previous command is under execution (BUSY low) causes the command to be ignored and the NOTPERF_CMD to rise ([Section 9.1.21](#)).

9.2.13 GoMark

Table 59. GoMark command structure

Bit 7	Bit 6	Bit 5	Bit 4	Bit 3	Bit 2	Bit 1	Bit 0	
0	1	1	1	1	0	0	0	from host

The GoMark command produces a motion to the MARK position performing the minimum path.

Note that, this command is equivalent to the “GoTo (MARK)” command. If a motor direction is mandatory, the GoTo_DIR command must be used.

The GoMark command keeps the BUSY flag low until the MARK position is reached. This command can be given only when the previous motion command has been completed (BUSY flag released).

Any attempt to perform a GoMark command when a previous command is under execution (BUSY low) causes the command to be ignored and the NOTPERF_CMD flag to rise ([Section 9.1.21](#)).

9.2.14 ResetPos

Table 60. ResetPos command structure

Bit 7	Bit 6	Bit 5	Bit 4	Bit 3	Bit 2	Bit 1	Bit 0	
1	1	0	1	1	0	0	0	from host

The ResetPos command resets the ABS_POS register to zero. The zero position is also defined as the HOME position ([Section 6.5](#)).

9.2.15 ResetDevice

Table 61. ResetDevice command structure

Bit 7	Bit 6	Bit 5	Bit 4	Bit 3	Bit 2	Bit 1	Bit 0	
1	1	0	0	0	0	0	0	from host

The ResetDevice command resets the device to power-up conditions ([Section 6.1](#)).

Note: At power-up the power bridges are disabled.

9.2.16 SoftStop

Table 62. SoftStop command structure

Bit 7	Bit 6	Bit 5	Bit 4	Bit 3	Bit 2	Bit 1	Bit 0	
1	0	1	1	0	0	0	0	from host

The SoftStop command causes an immediate deceleration to zero speed and a consequent motor stop; the deceleration value used is the one stored in the DEC register ([Section 9.1.6](#)).

When the motor is in high impedance state, a SoftStop command forces the bridges to exit from high impedance state; no motion is performed.

This command can be given anytime and is immediately executed. This command keeps the BUSY flag low until the motor is stopped.

9.2.17 HardStop

Table 63. HardStop command structure

Bit 7	Bit 6	Bit 5	Bit 4	Bit 3	Bit 2	Bit 1	Bit 0	
1	0	1	1	1	0	0	0	from host

The HardStop command causes an immediate motor stop with infinite deceleration.

When the motor is in high impedance state, a HardStop command forces the bridges to exit high impedance state; no motion is performed.

This command can be given anytime and is immediately executed. This command keeps the BUSY flag low until the motor is stopped.

9.2.18 SoftHiZ

Table 64. SoftHiZ command structure

Bit 7	Bit 6	Bit 5	Bit 4	Bit 3	Bit 2	Bit 1	Bit 0	
1	0	1	0	0	0	0	0	from host

The SoftHiZ command disables the power bridges (high impedance state) after a deceleration to zero; the deceleration value used is the one stored in the DEC register ([Section 9.1.6](#)). When bridges are disabled, the HiZ flag is raised.

When the motor is stopped, a SoftHiZ command forces the bridges to enter high impedance state.

This command can be given anytime and is immediately executed. This command keeps the BUSY flag low until the motor is stopped.

9.2.19 HardHiZ

Table 65. HardHiZ command structure

Bit 7	Bit 6	Bit 5	Bit 4	Bit 3	Bit 2	Bit 1	Bit 0	
1	0	1	0	1	0	0	0	from host

The HardHiZ command immediately disables the power bridges (high impedance state) and raises the HiZ flag.

When the motor is stopped, a HardHiZ command forces the bridges to enter high impedance state.

This command can be given anytime and is immediately executed.

This command keeps the BUSY flag low until the motor is stopped.

9.2.20 GetStatus

Table 66. GetStatus command structure

Bit 7	Bit 6	Bit 5	Bit 4	Bit 3	Bit 2	Bit 1	Bit 0	
1	1	0	1	0	0	0	0	from host
STATUS MSByte								to host
STATUS LSByte								to host

The GetStatus command returns the Status register value.

The GetStatus command resets the STATUS register warning flags. The command forces the system to exit from any error state. The GetStatus command DOES NOT reset the HiZ flag.

10 Package mechanical data

In order to meet environmental requirements, ST offers these devices in different grades of ECOPACK® packages, depending on their level of environmental compliance. ECOPACK specifications, grade definitions and product status are available at: www.st.com. ECOPACK is an ST trademark.

Table 67. HTSSOP38 mechanical data

Symbol	mm		
	Min.	Typ.	Max.
A		-	1.1
A1	0.05	-	0.15
A2	0.85	0.9	0.95
b	0.17	-	0.27
c	0.09	-	0.20
D	9.60	9.70	9.80
E1	4.30	4.40	4.50
e	-	0.50	-
E	-	6.40	-
L	0.50	0.60	0.70
P	6.40	6.50	6.60
P1	3.10	3.20	3.30
∅	0°	-	8°

Figure 28. HTSSOP38 package dimensions

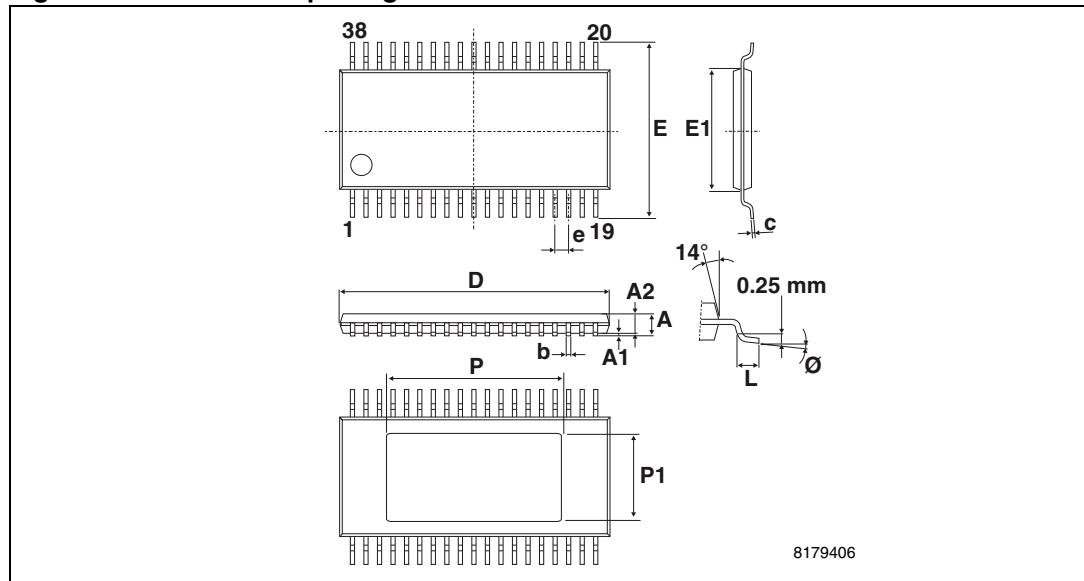
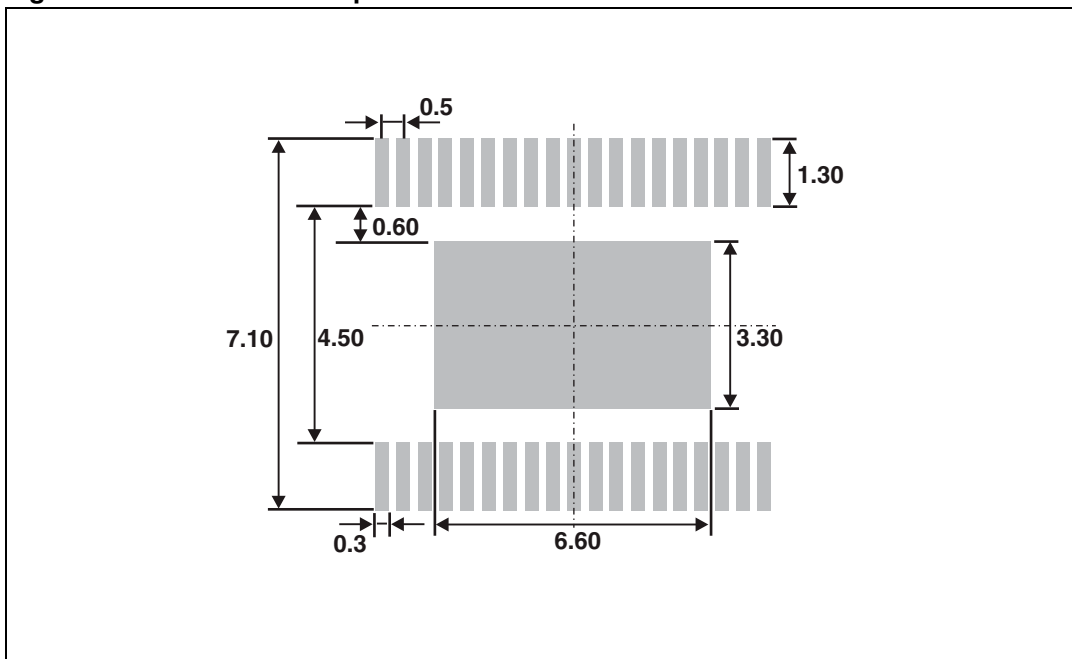

Figure 29. HTSSOP38 footprint



11 Revision history

Table 68. Document revision history

Date	Revision	Changes
08-Oct-2012	1	Initial release.
19-Dec-2012	2	Changed the title. Inserted footnote in Table 2 and Table 4 Removed Tj parameter in Table 3 . Updated Section 9.1.10 and Section 9.1.15 . Updated Table 17 . Minor text changes.

Please Read Carefully:

Information in this document is provided solely in connection with ST products. STMicroelectronics NV and its subsidiaries ("ST") reserve the right to make changes, corrections, modifications or improvements, to this document, and the products and services described herein at any time, without notice.

All ST products are sold pursuant to ST's terms and conditions of sale.

Purchasers are solely responsible for the choice, selection and use of the ST products and services described herein, and ST assumes no liability whatsoever relating to the choice, selection or use of the ST products and services described herein.

No license, express or implied, by estoppel or otherwise, to any intellectual property rights is granted under this document. If any part of this document refers to any third party products or services it shall not be deemed a license grant by ST for the use of such third party products or services, or any intellectual property contained therein or considered as a warranty covering the use in any manner whatsoever of such third party products or services or any intellectual property contained therein.

UNLESS OTHERWISE SET FORTH IN ST'S TERMS AND CONDITIONS OF SALE ST DISCLAIMS ANY EXPRESS OR IMPLIED WARRANTY WITH RESPECT TO THE USE AND/OR SALE OF ST PRODUCTS INCLUDING WITHOUT LIMITATION IMPLIED WARRANTIES OF MERCHANTABILITY, FITNESS FOR A PARTICULAR PURPOSE (AND THEIR EQUIVALENTS UNDER THE LAWS OF ANY JURISDICTION), OR INFRINGEMENT OF ANY PATENT, COPYRIGHT OR OTHER INTELLECTUAL PROPERTY RIGHT.

UNLESS EXPRESSLY APPROVED IN WRITING BY TWO AUTHORIZED ST REPRESENTATIVES, ST PRODUCTS ARE NOT RECOMMENDED, AUTHORIZED OR WARRANTED FOR USE IN MILITARY, AIR CRAFT, SPACE, LIFE SAVING, OR LIFE SUSTAINING APPLICATIONS, NOR IN PRODUCTS OR SYSTEMS WHERE FAILURE OR MALFUNCTION MAY RESULT IN PERSONAL INJURY, DEATH, OR SEVERE PROPERTY OR ENVIRONMENTAL DAMAGE. ST PRODUCTS WHICH ARE NOT SPECIFIED AS "AUTOMOTIVE GRADE" MAY ONLY BE USED IN AUTOMOTIVE APPLICATIONS AT USER'S OWN RISK.

Resale of ST products with provisions different from the statements and/or technical features set forth in this document shall immediately void any warranty granted by ST for the ST product or service described herein and shall not create or extend in any manner whatsoever, any liability of ST.

ST and the ST logo are trademarks or registered trademarks of ST in various countries.

Information in this document supersedes and replaces all information previously supplied.

The ST logo is a registered trademark of STMicroelectronics. All other names are the property of their respective owners.

© 2012 STMicroelectronics - All rights reserved

STMicroelectronics group of companies

Australia - Belgium - Brazil - Canada - China - Czech Republic - Finland - France - Germany - Hong Kong - India - Israel - Italy - Japan - Malaysia - Malta - Morocco - Philippines - Singapore - Spain - Sweden - Switzerland - United Kingdom - United States of America

www.st.com