

The S-8225B Series includes high-accuracy voltage detection circuits and delay circuits, and can monitor the status of 3-serial to 5-serial cell lithium-ion rechargeable battery in single use. By switching the voltage level which is applied to the SEL1 pin and SEL2 pin, users are able to use the S-8225B Series for 3-serial to 5-serial cell pack.

■ Features

- High-accuracy voltage detection function for each cell

Overcharge detection voltage n (n = 1 to 5)	3.5 V to 4.4 V (50 mV step)	Accuracy ± 20 mV ($T_a = +25^\circ\text{C}$), ± 30 mV ($T_a = 0^\circ\text{C}$ to $+60^\circ\text{C}$)
Overcharge release voltage n (n = 1 to 5)	3.3 V to 4.4 V ^{*1}	Accuracy ± 50 mV
Overdischarge detection voltage n (n = 1 to 5)	2.2 V to 3.2 V (100 mV step)	Accuracy ± 80 mV
Overdischarge release voltage n (n = 1 to 5)	2.2 V to 3.4 V ^{*2}	Accuracy ± 100 mV
 - Overcharge detection delay time and overdischarge detection delay time can be set by external capacitor.
 - Switchable between 3-serial to 5-serial cell by using the SEL1 pin and the SEL2 pin
 - The CO pin and the DO pin are controlled by the CTLC pin and the CTLD pin, respectively.
 - Output voltage of the CO pin and the DO pin is limited to 12 V max.
 - Output logic is selectable. Active "H", active "L"
 - High-withstand voltage Absolute maximum rating: 28 V
 - Wide operation voltage range 4 V to 26 V
 - Wide operation temperature range $T_a = -40^\circ\text{C}$ to $+85^\circ\text{C}$
 - Low current consumption

During operation ($V_1 = V_2 = V_3 = V_4 = V_5 = 3.4$ V)	20 μA max. ($T_a = +25^\circ\text{C}$)
During power-down ($V_1 = V_2 = V_3 = V_4 = V_5 = 1.6$ V)	3.0 μA max. ($T_a = +25^\circ\text{C}$)
 - Lead-free (Sn 100%), halogen-free
- *1. Overcharge hysteresis voltage n (n = 1 to 5) is selectable in 0 V, or in 0.1 V to 0.4 V in 50 mV step.
(Overcharge hysteresis voltage = Overcharge detection voltage – Overcharge release voltage)
- *2. Overdischarge hysteresis voltage n (n = 1 to 5) is selectable in 0 V, or in 0.2 V to 0.7 V in 100 mV step.
(Overdischarge hysteresis voltage = Overdischarge release voltage – Overdischarge detection voltage)

■ Application

- Lithium-ion rechargeable battery pack

■ Package

- 16-Pin TSSOP

■ **Block Diagram**



Remark Diodes in the figure are parasitic diodes.

Figure 1

■ **Product Name Structure**

1. Product name

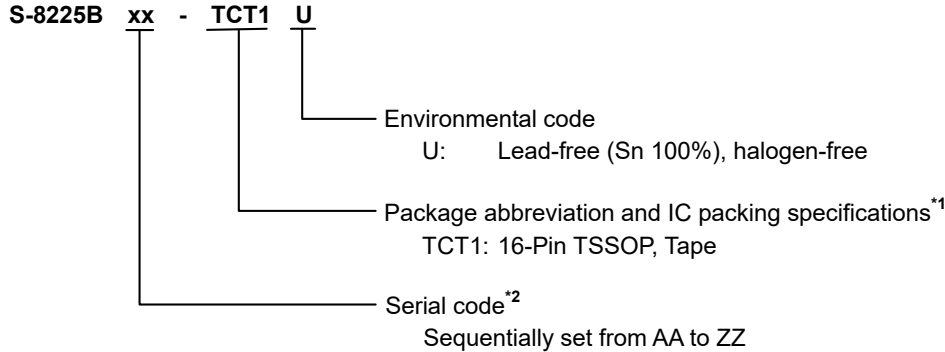

*1. Refer to the tape drawing.

*2. Refer to "3. Product name list".

2. Package

Table 1 Package Drawing Codes

Package Name	Dimension	Tape	Reel
16-Pin TSSOP	FT016-A-P-SD	FT016-A-C-SD	FT016-A-R-S1

3. Product name list

Table 2

Product Name	Overcharge Detection Voltage [V _{CU}]	Overcharge Release Voltage [V _{CL}]	Overdischarge Detection Voltage [V _{DL}]	Overdischarge Release Voltage [V _{DU}]	CO Pin Output Logic	DO Pin Output Logic	0 V Battery Detection Function
S-8225BAA-TCT1U	4.220 V	4.170 V	2.30 V	2.30 V	Active "H"	Active "L"	Unavailable
S-8225BAB-TCT1U	3.600 V	3.550 V	2.20 V	2.20 V	Active "H"	Active "L"	Unavailable
S-8225BAC-TCT1U	4.450 V	4.050 V	2.50 V	2.70 V	Active "H"	Active "L"	Unavailable
S-8225BAE-TCT1U	4.250 V	4.200 V	2.70 V	3.00 V	Active "H"	Active "H"	Unavailable
S-8225BAF-TCT1U	4.250 V	4.200 V	2.50 V	2.70 V	Active "H"	Active "H"	Unavailable
S-8225BAG-TCT1U	4.275 V	4.225 V	2.30 V	2.80 V	Active "H"	Active "H"	Unavailable
S-8225BAH-TCT1U	3.900 V	3.600 V	2.20 V	2.40 V	Active "H"	Active "H"	Available
S-8225BAI-TCT1U	4.195 V	4.195 V	2.50 V	3.00 V	Active "H"	Active "H"	Available
S-8225BAJ-TCT1U	4.170 V	4.170 V	2.50 V	3.00 V	Active "H"	Active "H"	Available
S-8225BAK-TCT1U	4.225 V	4.025 V	2.20 V	2.90 V	Active "H"	Active "H"	Unavailable

Remark Please contact our sales office for products other than the above.

■ **Pin Configuration**

1. **16-Pin TSSOP**

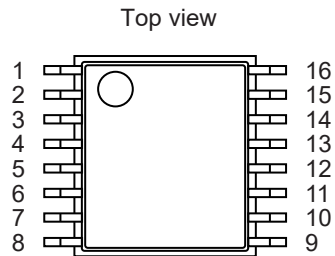

Figure 2

Table 3

Pin No.	Symbol	Description
1	CTLD	DO control pin
2	CTLC	CO control pin
3	CO	Output pin for overcharge detection
4	DO	Output pin for overdischarge detection
5	SEL1	Switching pins for 3-serial to 5-serial cell*1
6	SEL2	
7	CDT	Capacitor connection pin for delay for overdischarge detection voltage
8	CCT	Capacitor connection pin for delay for overcharge detection voltage
9	VSS	Input pin for negative power supply, connection pin for negative voltage of battery 5
10	VC6	Connection pin for negative voltage of battery 5
11	VC5	Connection pin for negative voltage of battery 4, connection pin for positive voltage of battery 5
12	VC4	Connection pin for negative voltage of battery 3, connection pin for positive voltage of battery 4
13	VC3	Connection pin for negative voltage of battery 2, connection pin for positive voltage of battery 3
14	VC2	Connection pin for negative voltage of battery 1, connection pin for positive voltage of battery 2
15	VC1	Connection pin for positive voltage of battery 1
16	VDD	Input pin for positive power supply, connection pin for positive voltage of battery 1

*1. Refer to "7. SEL pin" in "■ Operation" for setting of the SEL1 pin and the SEL2 pin.

■ **Absolute Maximum Ratings**

Table 4

(Ta = +25°C unless otherwise specified)

Item	Symbol	Applied Pin	Absolute Maximum Rating	Unit
Input voltage between VDD pin and VSS pin	V _{DS}	VDD	V _{SS} – 0.3 to V _{SS} + 28	V
Input pin voltage	V _{IN}	VC1, VC2, VC3, VC4, VC5, VC6, SEL1, SEL2, CTLC, CTLD, CCT, CDT	V _{SS} – 0.3 to V _{DD} + 0.3	V
Output pin voltage	V _{OUT}	DO, CO	V _{SS} – 0.3 to V _{DD} + 0.3	V
Power dissipation	P _D	–	1100*1	mW
Operation ambient temperature	T _{opr}	–	–40 to +85	°C
Storage temperature	T _{stg}	–	–40 to +125	°C

- *1. When mounted on board
 [Mounted board]
 (1) Board size: 114.3 mm × 76.2 mm × t1.6 mm
 (2) Board name: JEDEC STANDARD51-7

Caution The absolute maximum ratings are rated values exceeding which the product could suffer physical damage. These values must therefore not be exceeded under any conditions.

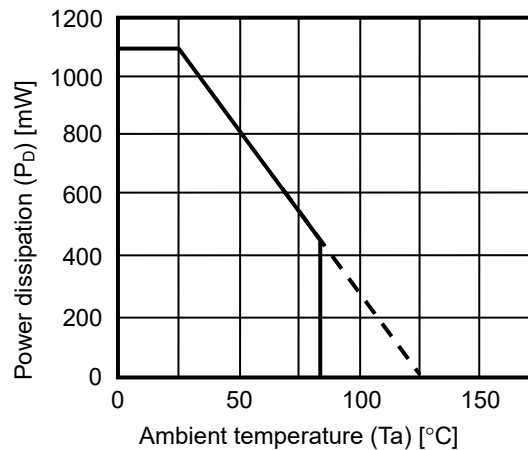

Figure 3 Power Dissipation of Package (When Mounted on Board)

■ **Electrical Characteristics**

Table 5 (1 / 2)

(Ta = +25°C, V_{DS} = V_{DD} - V_{SS} = V₁ + V₂ + V₃ + V₄ + V₅ unless otherwise specified)

Item	Symbol	Condition	Min.	Typ.	Max.	Unit	Test Circuit
Detection Voltage							
Overcharge detection voltage n (n = 1, 2, 3, 4, 5)	V _{CU_n}	Ta = +25°C V ₁ = V ₂ = V ₃ = V ₄ = V ₅ = V _{CU} - 0.05 V	V _{CU_n} - 0.020	V _{CU_n}	V _{CU_n} + 0.020	V	1
		Ta = 0°C to +60°C*1 V ₁ = V ₂ = V ₃ = V ₄ = V ₅ = V _{CU} - 0.05 V	V _{CU_n} - 0.030	V _{CU_n}	V _{CU_n} + 0.030	V	1
Overcharge release voltage n (n = 1, 2, 3, 4, 5)	V _{CL_n}	-	V _{CL_n} - 0.050	V _{CL_n}	V _{CL_n} + 0.050	V	1
Overdischarge detection voltage n (n = 1, 2, 3, 4, 5)	V _{DL_n}	-	V _{DL_n} - 0.08	V _{DL_n}	V _{DL_n} + 0.08	V	1
Overdischarge release voltage n (n = 1, 2, 3, 4, 5)	V _{DU_n}	-	V _{DU_n} - 0.10	V _{DU_n}	V _{DU_n} + 0.10	V	1
0 V battery detection voltage n (n = 1, 2, 3, 4, 5)	V _{0INH_n}	0 V battery detection function "available"	0.4	0.7	1.1	V	1
Delay Time Function*2							
Overcharge detection delay time	t _{CU}	C _{CC_T} = 0.1 μF	0.67	1.00	1.33	s	2
Overdischarge detection delay time	t _{DL}	C _{CD_T} = 0.1 μF	0.67	1.00	1.33	s	2
CCT pin voltage	V _{CCT}	-	-	1.5	5.0	V	2
CDT pin voltage	V _{CDT}	-	-	1.5	5.0	V	2
Input Voltage							
Operation voltage between V _{DD} pin and V _{SS} pin	V _{DSOP}	Fixed output voltage of CO pin and DO pin	4	-	26	V	-
CTLC pin voltage "H"	V _{CTLCH}	-	V _{DS} - 4.0	-	V _{DS} - 0.5	V	3
CTLC pin voltage "L"	V _{CTLCL}	-	0.5	-	4.0	V	3
CTLD pin voltage "H"	V _{CTLDH}	-	V _{DS} - 4.0	-	V _{DS} - 0.5	V	3
CTLD pin voltage "L"	V _{CTLDL}	-	0.5	-	4.0	V	3
SEL1 pin voltage "H"	V _{SELH1}	-	V _{DS} × 0.8	-	-	V	3
SEL2 pin voltage "H"	V _{SELH2}	-	V _{DS} × 0.8	-	-	V	3
SEL1 pin voltage "L"	V _{SELL1}	-	-	-	V _{DS} × 0.2	V	3
SEL2 pin voltage "L"	V _{SELL2}	-	-	-	V _{DS} × 0.2	V	3
Output Voltage							
CO pin voltage "H"	V _{COH}	-	5.0	8.0	12.0	V	4
DO pin voltage "H"	V _{DOH}	-	5.0	8.0	12.0	V	4
Input Current							
Current consumption during operation	I _{OPE}	V ₁ = V ₂ = V ₃ = V ₄ = V ₅ = 3.4 V	-	12	20	μA	5
Current consumption during power-down	I _{PDN}	V ₁ = V ₂ = V ₃ = V ₄ = V ₅ = 1.6 V	-	1.6	3.0	μA	5
VC1 pin current	I _{VC1}	V ₁ = V ₂ = V ₃ = V ₄ = V ₅ = 3.4 V, V ₆ = V ₇ = V _{DS} , V ₈ = V ₉ = 0 V	-	0.4	0.8	μA	6
VC2 to VC5 pins current	I _{VC2 to VC5}	V ₁ = V ₂ = V ₃ = V ₄ = V ₅ = 3.4 V, V ₆ = V ₇ = V _{DS} , V ₈ = V ₉ = 0 V	-1.0	-	1.0	μA	6
VC6 pin current	I _{VC6}	V ₁ = V ₂ = V ₃ = V ₄ = V ₅ = 3.4 V, V ₆ = V ₇ = V _{DS} , V ₈ = V ₉ = 0 V	-3.0	-1.0	-	μA	6
CTLC pin current "H"	I _{CTLCH}	V ₁ = V ₂ = V ₃ = V ₄ = V ₅ = 3.4 V, V ₆ = V ₇ = V _{DS} , V ₈ = V ₉ = 0 V	-	-	0.1	μA	6
CTLC pin current "L"	I _{CTLCL}	V ₁ = V ₂ = V ₃ = V ₄ = V ₅ = 3.4 V, V ₇ = V _{DS} , V ₆ = V ₈ = V ₉ = 0 V	-0.1	-	-	μA	6

BATTERY MONITORING IC FOR 3-SERIAL TO 5-SERIAL CELL PACK
S-8225B Series

Rev.1.6_00

Table 5 (2 / 2)

(Ta = +25°C, V_{DS} = V_{DD} - V_{SS} = V1 + V2 + V3 + V4 + V5 unless otherwise specified)

Item	Symbol	Condition	Min.	Typ.	Max.	Unit	Test Circuit
CTLD pin current "H"	I _{CTLDH}	V1 = V2 = V3 = V4 = V5 = 3.4 V, V6 = V7 = V _{DS} , V8 = V9 = 0 V	–	–	0.1	μA	6
CTLD pin current "L"	I _{CTLDL}	V1 = V2 = V3 = V4 = V5 = 3.4 V, V6 = V _{DS} , V7 = V8 = V9 = 0 V	–0.1	–	–	μA	6
SEL1 pin current "H"	I _{SELH1}	V1 = V2 = V3 = V4 = V5 = 3.4 V, V6 = V7 = V8 = V _{DS} , V9 = 0 V	–	–	0.1	μA	6
SEL2 pin current "H"	I _{SELH2}	V1 = V2 = V3 = V4 = V5 = 3.4 V, V6 = V7 = V9 = V _{DS} , V8 = 0 V	–	–	0.1	μA	6
SEL1 pin current "L"	I _{SELL1}	V1 = V2 = V3 = V4 = V5 = 3.4 V, V6 = V7 = V _{DS} , V8 = V9 = 0 V	–0.1	–	–	μA	6
SEL2 pin current "L"	I _{SELL2}	V1 = V2 = V3 = V4 = V5 = 3.4 V, V6 = V7 = V _{DS} , V8 = V9 = 0 V	–0.1	–	–	μA	6
Output Current (CO Pin Output Logic Active "H")							
CO pin source current	I _{COH}	–	–	–	–10	μA	7
CO pin sink current	I _{COL}	–	10	–	–	μA	7
Output Current (CO Pin Output Logic Active "L")							
CO pin source current	I _{COH}	–	–	–	–10	μA	7
CO pin sink current	I _{COL}	–	10	–	–	μA	7
Output Current (DO Pin Output Logic Active "H")							
DO pin source current	I _{DOH}	–	–	–	–10	μA	7
DO pin sink current	I _{DOL}	–	10	–	–	μA	7
Output Current (DO Pin Output Logic Active "L")							
DO pin source current	I _{DOH}	–	–	–	–10	μA	7
DO pin sink current	I _{DOL}	–	10	–	–	μA	7

- *1. Since products are not screened at high and low temperature, the specification for this temperature range is guaranteed by design, not tested in production.
- *2. Refer to "6. Delay time setting" in "■ Operation" for details of the delay time function.

■ Test Circuits

**1. Overcharge detection voltage (V_{CU_n}), overcharge release voltage (V_{CL_n}), overdischarge detection voltage (V_{DL_n}), overdischarge release voltage (V_{DU_n})
(Test circuit 1)**

V_{CU_1} is defined as the voltage V_1 when V_1 is gradually increased and the CO pin output becomes detection status after setting $V_1 = V_2 = V_3 = V_4 = V_5 = V_{CU} - 0.05$ V. After that, V_{CL_1} is defined as the voltage V_1 when V_1 is gradually decreased and the CO pin output becomes release status after setting $V_2 = V_3 = V_4 = V_5 = 3.2$ V. Moreover, V_{DL_1} is defined as the voltage V_1 when V_1 is gradually decreased and the DO pin output becomes detection status after setting $V_1 = V_2 = V_3 = V_4 = V_5 = 3.5$ V. After that, V_{DU_1} is defined as the voltage V_1 when V_1 is gradually increased and the DO pin output becomes release status.

Similarly, V_{CU_n} , V_{CL_n} , V_{DL_n} and V_{DU_n} can be defined by changing V_n ($n = 2$ to 5).

**2. 0 V battery detection voltage (V_{0INH_n}) (0 V battery detection function "available")
(Test circuit 1)**

V_{0INH_1} is defined as the voltage V_1 when V_1 is gradually decreased and the CO pin output becomes detection status after setting $V_1 = V_2 = V_3 = V_4 = V_5 = 3.4$ V.

Similarly, V_{0INH_n} can be defined by changing V_n ($n = 2$ to 5).

**3. Overcharge detection delay time (t_{CU}), overdischarge detection delay time (t_{DL})
(Test circuit 2)**

t_{CU} is defined as the time period from when V_1 changes from 3.4 V to 4.5 V to when the CO pin output becomes detection status after setting $V_1 = V_2 = V_3 = V_4 = V_5 = 3.4$ V.

Moreover, t_{DL} is defined as the time period from when V_1 changes from 3.4 V to 1.6 V to when the DO pin output becomes detection status after setting $V_1 = V_2 = V_3 = V_4 = V_5 = 3.4$ V.

**4. CCT pin voltage (V_{CCT}), CDT pin voltage (V_{CDT})
(Test circuit 2)**

V_{CCT} is defined as the voltage between the CCT pin and the VSS pin during the time period when V_1 changes from 3.4 V to 4.5 V to when the CO pin output becomes detection status after setting $V_1 = V_2 = V_3 = V_4 = V_5 = 3.4$ V.

Moreover, V_{CDT} is defined as the voltage between the CDT pin and the VSS pin during the time period when V_1 changes from 3.4 V to 1.6 V to when the DO pin output becomes detection status after setting $V_1 = V_2 = V_3 = V_4 = V_5 = 3.4$ V.

**5. CTLC pin voltage "H" (V_{CTLCH}), CTLC pin voltage "L" (V_{CTLCL}), CTLD pin voltage "H" (V_{CTLDH}), CTLD pin voltage "L" (V_{CTLDL})
(Test circuit 3)**

V_{CTLCL} is defined as the voltage V_6 when V_6 is gradually decreased and the CO pin output becomes detection status after setting $V_1 = V_2 = V_3 = V_4 = V_5 = 3.4$ V, $V_6 = V_7 = V_{DS} (= V_1 + V_2 + V_3 + V_4 + V_5)$, $V_8 = V_9 = 0$ V. After that, V_{CTLCH} is defined as the voltage V_6 when V_6 is gradually increased and the CO pin output becomes release status. Moreover, V_{CTLDL} is defined as the voltage V_7 when V_7 is gradually decreased and the DO pin output becomes detection status after setting $V_1 = V_2 = V_3 = V_4 = V_5 = 3.4$ V, $V_6 = V_7 = V_{DS} (= V_1 + V_2 + V_3 + V_4 + V_5)$, $V_8 = V_9 = 0$ V. After that, V_{CTLDH} is defined as the voltage V_7 when V_7 is gradually increased and the DO pin output becomes release status.

**6. SEL1 pin voltage "H" (V_{SELH1}), SEL2 pin voltage "H" (V_{SELH2}), SEL1 pin voltage "L" (V_{SELL1}), SEL2 pin voltage "L" (V_{SELL2})
(Test circuit 3)**

V_{SELH1} is defined as the voltage $V8$ when $V8$ is gradually increased and the DO pin output becomes release status after setting $V1 = V2 = V3 = V5 = 3.5\text{ V}$, $V4 = 0\text{ V}$, $V6 = V7 = V_{DS} (= V1 + V2 + V3 + V4 + V5)$, $V8 = V9 = 0\text{ V}$. After that, V_{SELL1} is defined as the voltage $V8$ when $V8$ is gradually decreased and the DO pin output becomes detection status.

Moreover, V_{SELH2} is defined as the voltage $V9$ when $V9$ is gradually increased and the DO pin output becomes release status after setting $V1 = V2 = V3 = V4 = 3.5\text{ V}$, $V5 = 0\text{ V}$, $V6 = V7 = V_{DS} (= V1 + V2 + V3 + V4 + V5)$, $V8 = V9 = 0\text{ V}$. After that, V_{SELL2} is defined as the voltage $V9$ when $V9$ is gradually decreased and the DO pin output becomes detection status.

**7. CO pin voltage "H" (V_{COH}), DO pin voltage "H" (V_{DOH})
(Test circuit 4)**

7.1 CO pin output logic active "H"

V_{COH} is defined as the voltage between the CO pin and the VSS pin when $V1 = 6.8\text{ V}$, $V2 = 0\text{ V}$, $V3 = V4 = V5 = 3.4\text{ V}$.

7.2 CO pin output logic active "L"

V_{COH} is defined as the voltage between the CO pin and the VSS pin when $V1 = V2 = V3 = V4 = V5 = 3.4\text{ V}$.

7.3 DO pin output logic active "H"

V_{DOH} is defined as the voltage between the DO pin and the VSS pin when $V1 = 6.8\text{ V}$, $V2 = 0\text{ V}$, $V3 = V4 = V5 = 3.4\text{ V}$.

7.4 DO pin output logic active "L"

V_{DOH} is defined as the voltage between the DO pin and the VSS pin when $V1 = V2 = V3 = V4 = V5 = 3.4\text{ V}$.

**8. CO pin source current (I_{COH}), CO pin sink current (I_{COL}), DO pin source current (I_{DOH}), DO pin sink current (I_{DOL})
(Test circuit 7)**

8.1 CO pin output logic active "H"

I_{COH} is defined as the CO pin current when $V1 = 6.8\text{ V}$, $V2 = 0\text{ V}$, $V3 = V4 = V5 = 3.4\text{ V}$, $V6 = V_{COH} - 0.5\text{ V}$.
 I_{COL} is defined as the CO pin current when $V1 = V2 = V3 = V4 = V5 = 3.4\text{ V}$, $V6 = 0.5\text{ V}$.

8.2 CO pin output logic active "L"

I_{COH} is defined as the CO pin current when $V1 = V2 = V3 = V4 = V5 = 3.4\text{ V}$, $V6 = V_{COH} - 0.5\text{ V}$.
 I_{COL} is defined as the CO pin current when $V1 = 6.8\text{ V}$, $V2 = 0\text{ V}$, $V3 = V4 = V5 = 3.4\text{ V}$, $V6 = 0.5\text{ V}$.

8.3 DO pin output logic active "H"

I_{DOH} is defined as the DO pin current when $V1 = 6.8\text{ V}$, $V2 = 0\text{ V}$, $V3 = V4 = V5 = 3.4\text{ V}$, $V7 = V_{DOH} - 0.5\text{ V}$.
 I_{DOL} is defined as the DO pin current when $V1 = V2 = V3 = V4 = V5 = 3.4\text{ V}$, $V7 = 0.5\text{ V}$.

8.4 DO pin output logic active "L"

I_{DOH} is defined as the DO pin current when $V1 = V2 = V3 = V4 = V5 = 3.4\text{ V}$, $V7 = V_{DOH} - 0.5\text{ V}$.
 I_{DOL} is defined as the DO pin current when $V1 = 6.8\text{ V}$, $V2 = 0\text{ V}$, $V3 = V4 = V5 = 3.4\text{ V}$, $V7 = 0.5\text{ V}$.

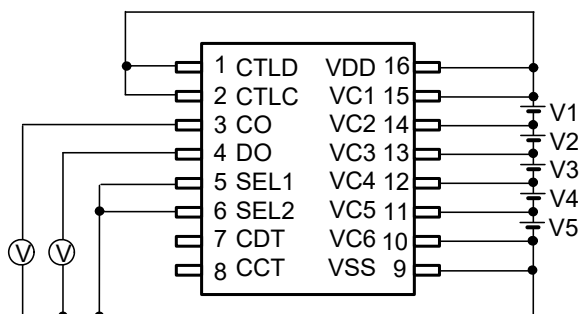

Figure 4 Test Circuit 1

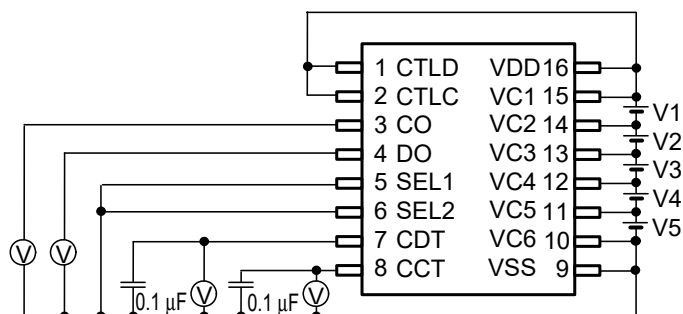

Figure 5 Test Circuit 2

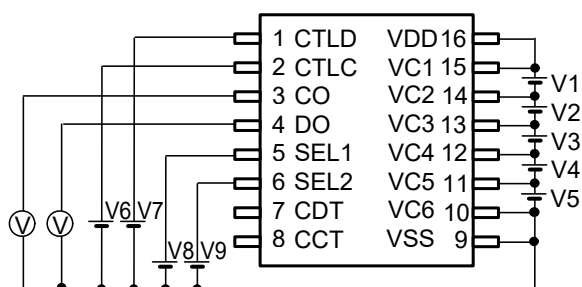

Figure 6 Test Circuit 3

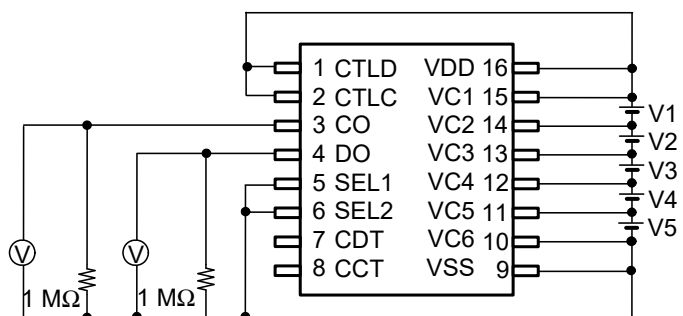

Figure 7 Test Circuit 4

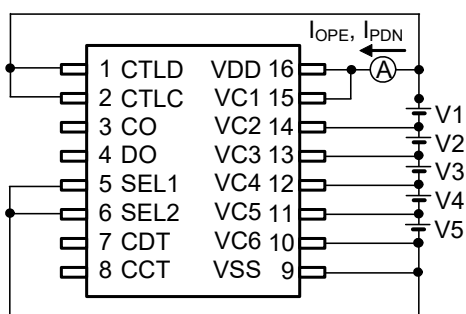

Figure 8 Test Circuit 5

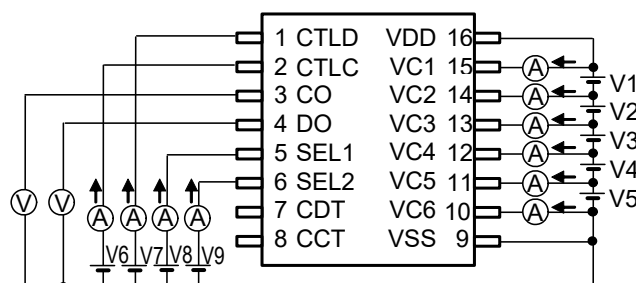

Figure 9 Test Circuit 6

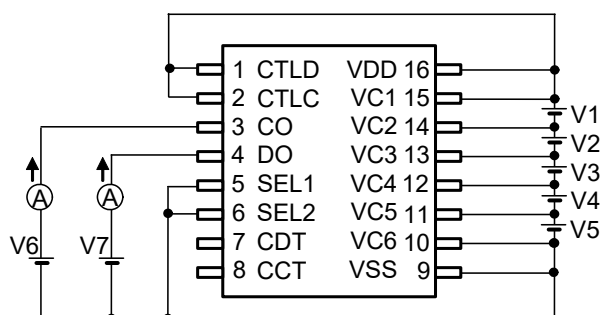

Figure 10 Test Circuit 7

■ Operation

Remark Refer to "■ Connection Examples of Battery Monitoring IC".

1. Normal status

When the voltage of each of the batteries is in the range from overcharge detection voltage (V_{CUH}) to overdischarge detection voltage (V_{DLH}), and the CTLC pin input voltage (V_{CTLC}) and the CTLD pin input voltage (V_{CTLD}) are higher than the CTLC pin voltage "H" (V_{CTLCH}) and the CTLD pin voltage "H" (V_{CTLDH}), respectively, the S-8225B Series defines the CO pin output voltage (V_{CO}) and the DO pin output voltage (V_{DO}) as "L" (output logic active "H") or "H" (output logic active "L"). This is called normal status.

V_{CO} is defined as the CO pin voltage "H" (V_{COH}) when it is "H". Similarly, V_{DO} is defined as the DO pin voltage "H" (V_{DOH}) when it is "H".

2. Overcharge status

When the voltage of one of the batteries becomes V_{CUH} or higher, the CO pin output inverts and the S-8225B Series becomes detection status. This is called overcharge status.

When the voltage of each of the batteries becomes overcharge release voltage (V_{CLH}) or lower, the overcharge status is released and the S-8225B Series returns to normal status.

3. Overdischarge status

When the voltage of one of the batteries becomes V_{DLH} or lower, the DO pin output inverts and the S-8225B Series becomes detection status. This is called overdischarge status.

When the voltage of each of the batteries becomes overdischarge release voltage (V_{DUH}) or higher, the overdischarge status is released and the S-8225B Series returns to normal status.

4. CTLC pin and CTLD pin

The S-8225B Series has two pins to control.

The CTLC pin controls the output voltage from the CO pin; the CTLD pin controls the output voltage from the DO pin. Thus it is possible for users to control the output voltages from the CO pin and DO pin, respectively. These controls precede the battery protection circuit.

Table 6 Status Set by CTLC Pin

CTLC Pin	CO Pin
"H" ^{*1}	Normal status ^{*3}
"L" ^{*2}	Detection status

*1. "H": $CTLC \geq V_{CTLCH}$

*2. "L": $CTLC \leq V_{CTLCL}$

*3. The status is controlled by the voltage detection circuit.

Table 7 Status Set by CTLD Pin

CTLD Pin	DO Pin
"H" ^{*1}	Normal status ^{*3}
"L" ^{*2}	Detection status

*1. "H": $CTLD \geq V_{CTLDH}$

*2. "L": $CTLD \leq V_{CTLDL}$

*3. The status is controlled by the voltage detection circuit.

5. 0 V battery detection function

In the S-8225B Series, users are able to select a 0 V battery detection "available" function.

If this optional function is selected, the CO pin becomes detection status when the voltage of one of the batteries becomes 0 V battery detection voltage (V_{0INHn}) or lower.

6. Delay time setting

When the voltage of one of the batteries becomes V_{CUH} or higher, the S-8225B Series charges the capacitor connected to the CCT pin rapidly up to the CCT pin voltage (V_{CCT}). After that, The S-8225B Series discharges the capacitor with the constant current of 100 nA, and the CO pin output is defined as detection status at the time when the CCT pin voltage falls to a certain level or lower. The overcharge detection delay time (t_{CU}) changes depending on the capacitor connected to the CCT pin.

t_{CU} is calculated by the following formula.

Min. Typ. Max.

$$t_{CU} [s] = (6.7, 10, 13.3) \times C_{CCT} [\mu F]$$

Similarly, the overdischarge detection delay time (t_{DL}) changes depending on the capacitor connected to the CDT pin. t_{DL} is calculated by the following formula.

Min. Typ. Max.

$$t_{DL} [s] = (6.7, 10, 13.3) \times C_{CDT} [\mu F]$$

Since the S-8225B Series charges the capacitor for delay rapidly, the voltage of the CCT pin and the CDT pin becomes large if the capacitance value is small. As a result, a variation between the calculated value of the delay time and the actual delay time is generated.

If the capacitance value is so large that the rapid charging can not be finished within the internal delay time, the output pin becomes detection status simultaneously with the end of internal delay time.

In addition, the charging current to the capacitor for delay passes through the VDD pin. Therefore, a large resistor connected to the VDD pin results in a big drop of the power supply voltage at the time of rapid charging which causes malfunction.

Regarding the recommended values for external components, refer to "Table 9 Constants for External Components".

7. SEL pin

In the S-8225B Series, switchable monitoring control between 3-cell to 5-cell is possible by using the SEL1 pin and the SEL2 pin. For example, since the overdischarge detection of V4 or V5 is prohibited and the overdischarge is not detected even if V4 or V5 is shorted when the SEL1 pin is "H" and the SEL2 pin is "L", the S-8225B Series can be used for 3-cell monitoring.

Be sure to use the SEL1 pin and the SEL2 pin at "H" or "L" potential.

Table 8 Settings of SEL1 Pin and SEL2 Pin

SEL1 pin	SEL2 pin	Setting
"H"*1	"H"*1	Prohibition
"H"*1	"L"*2	3-cell monitoring
"L"*2	"H"*1	4-cell monitoring
"L"*2	"L"*2	5-cell monitoring

*1. "H": $SEL1 \geq V_{SELH1}$ and $SEL2 \geq V_{SELH2}$

*2. "L": $SEL1 \leq V_{SELL1}$ and $SEL2 \leq V_{SELL2}$

■ **Timing Charts**

1. Overcharge detection and overdischarge detection

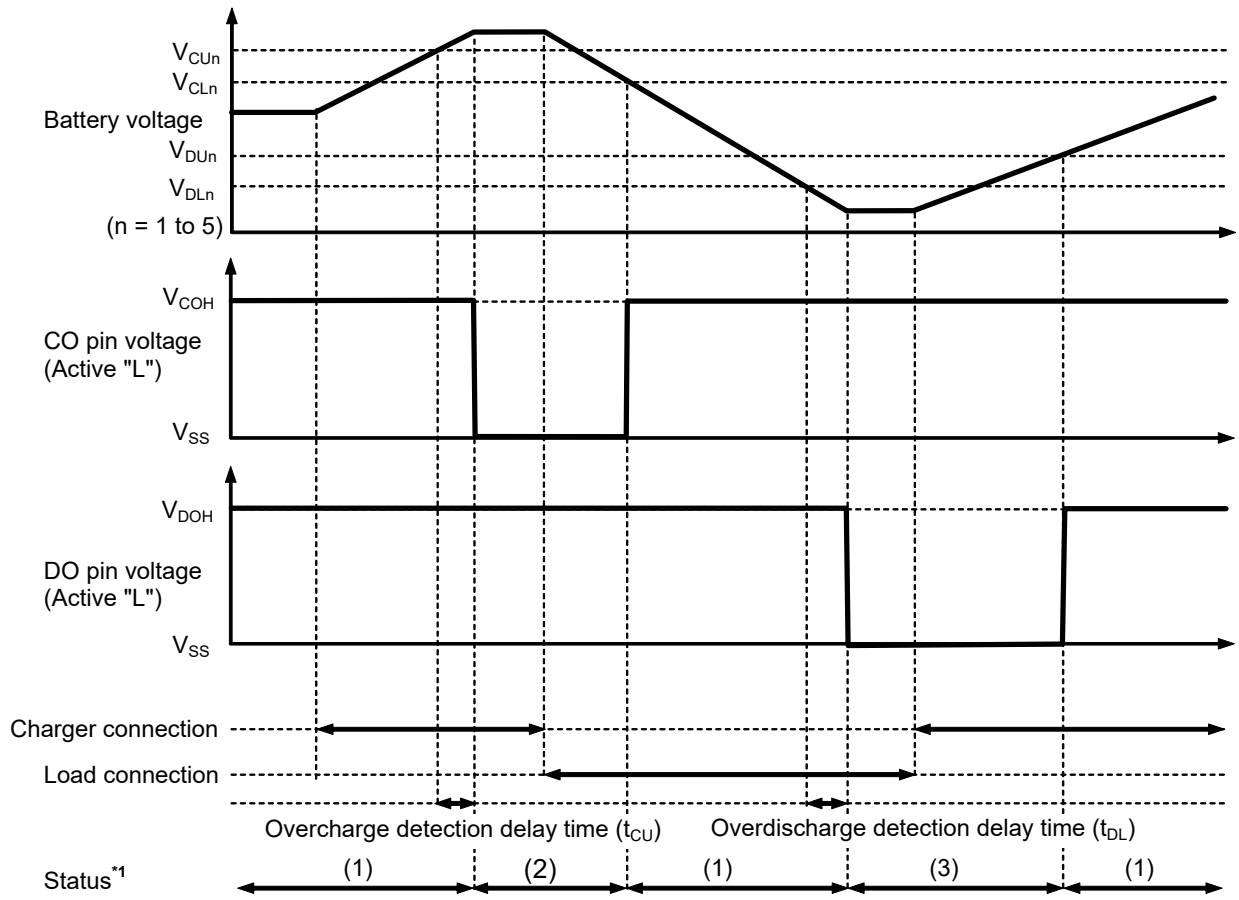

- *1. (1): Normal status
 (2): Overcharge status
 (3): Overdischarge status

Figure 11

2. Overcharge detection delay

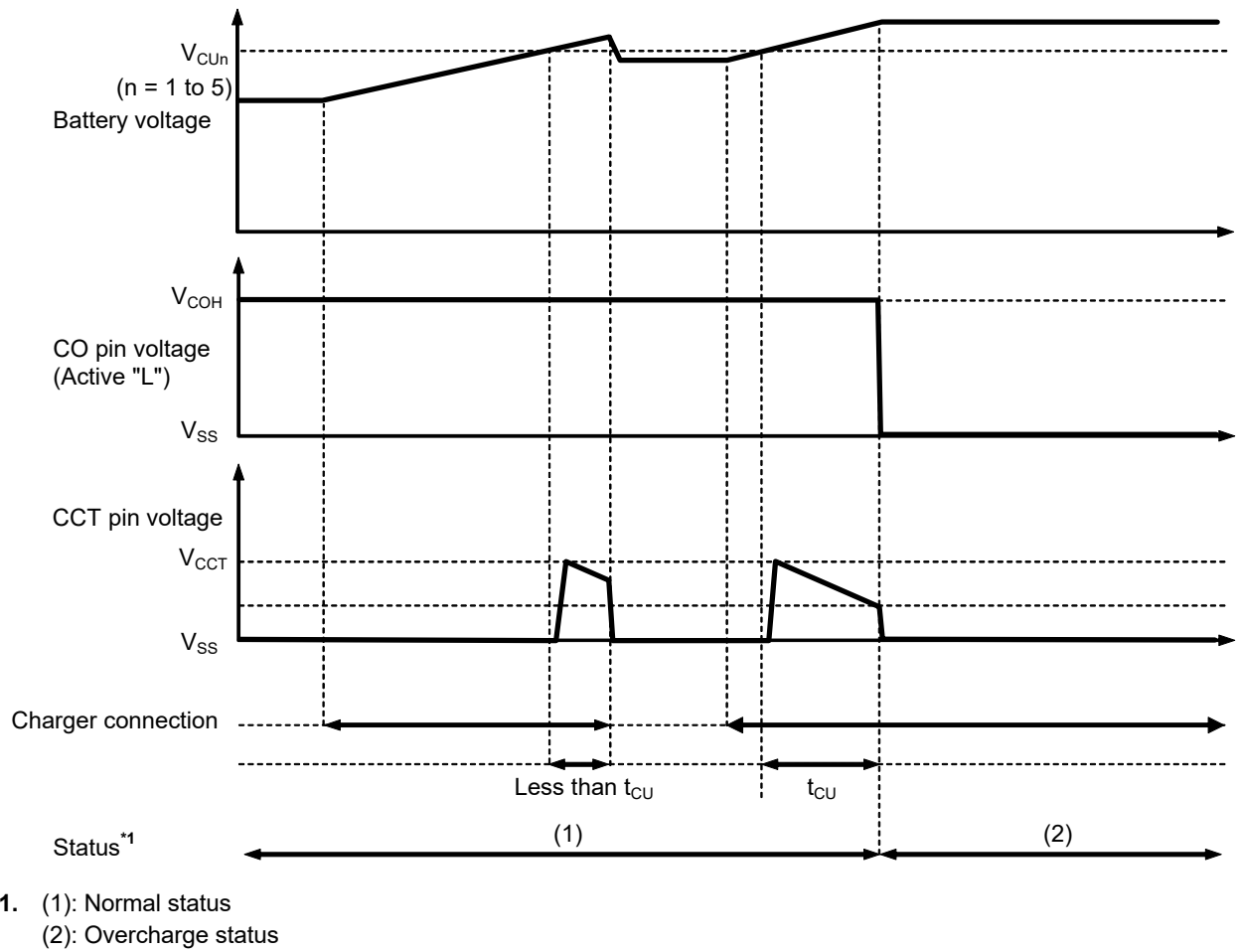

Figure 12

3. Overdischarge detection delay

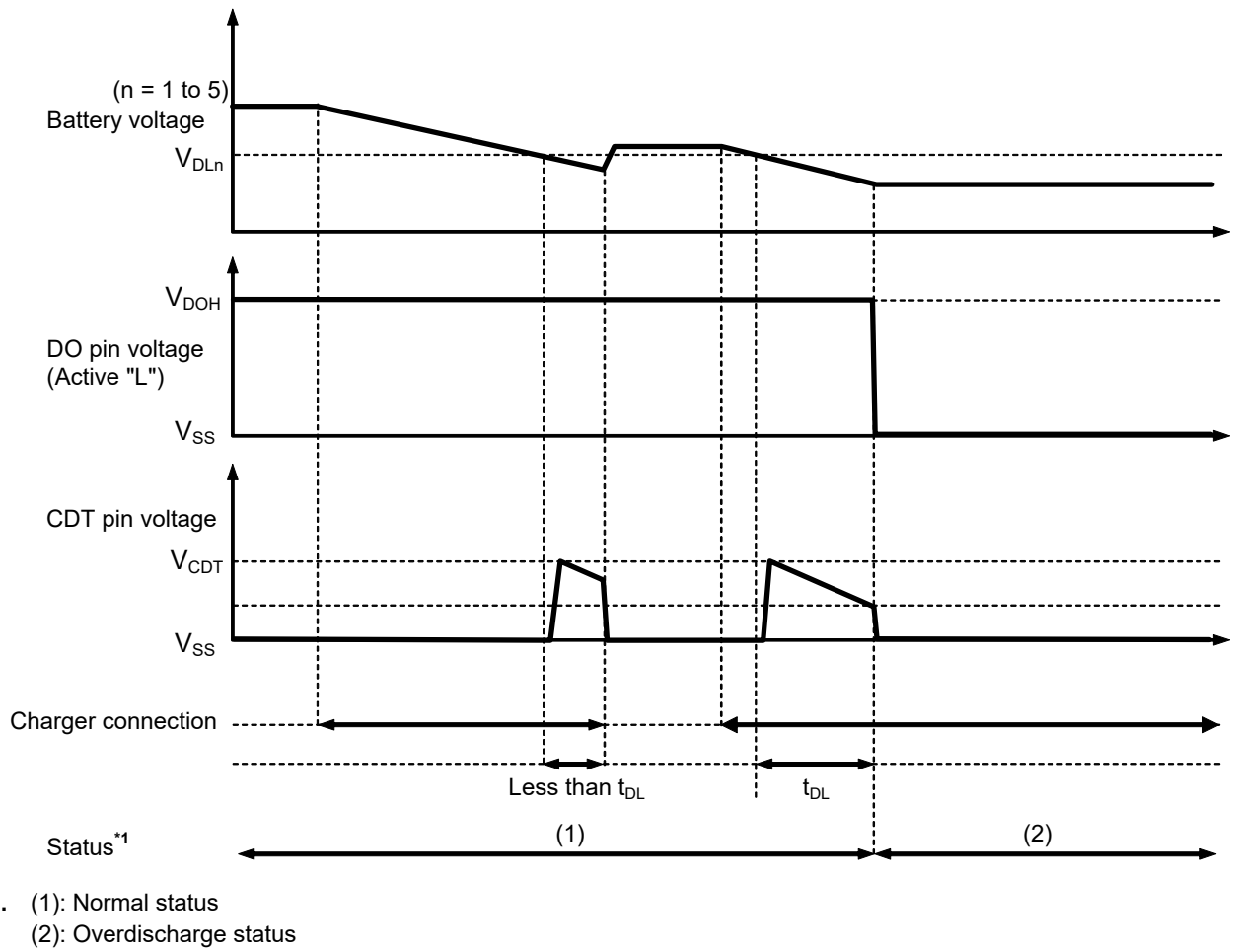

Figure 13

■ **Connection Examples of Battery Monitoring IC**

1. **5-serial cell**

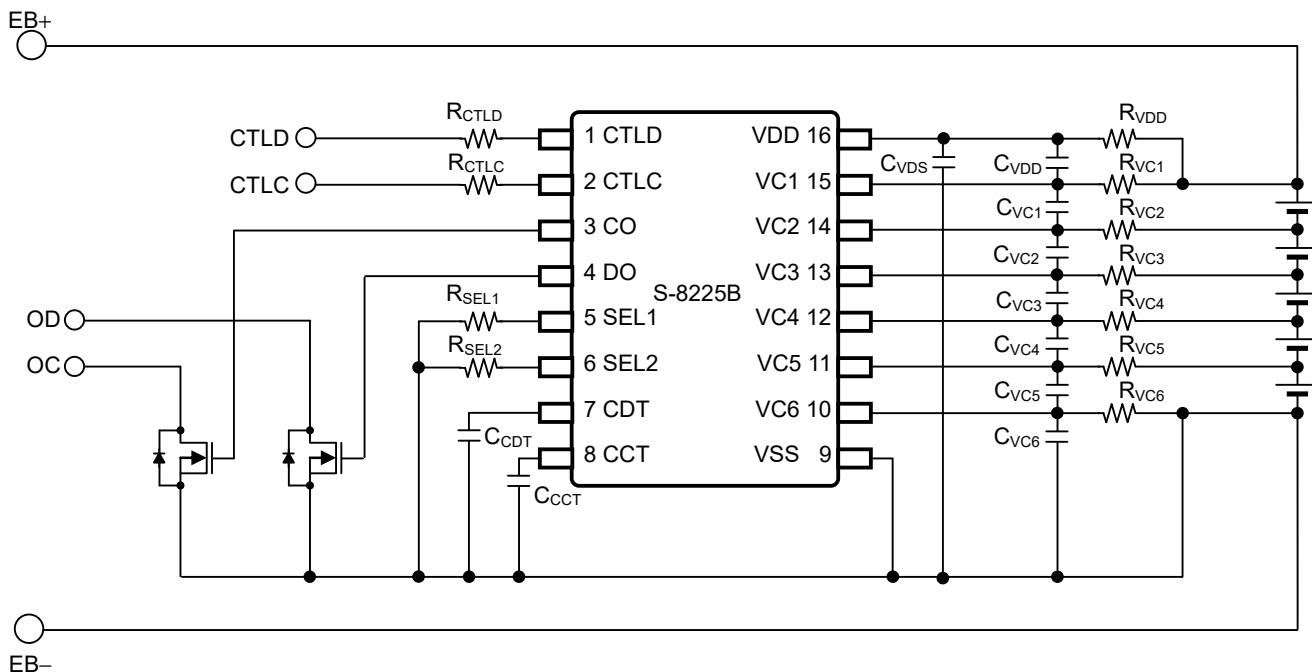

Figure 14

2. **4-serial cell**

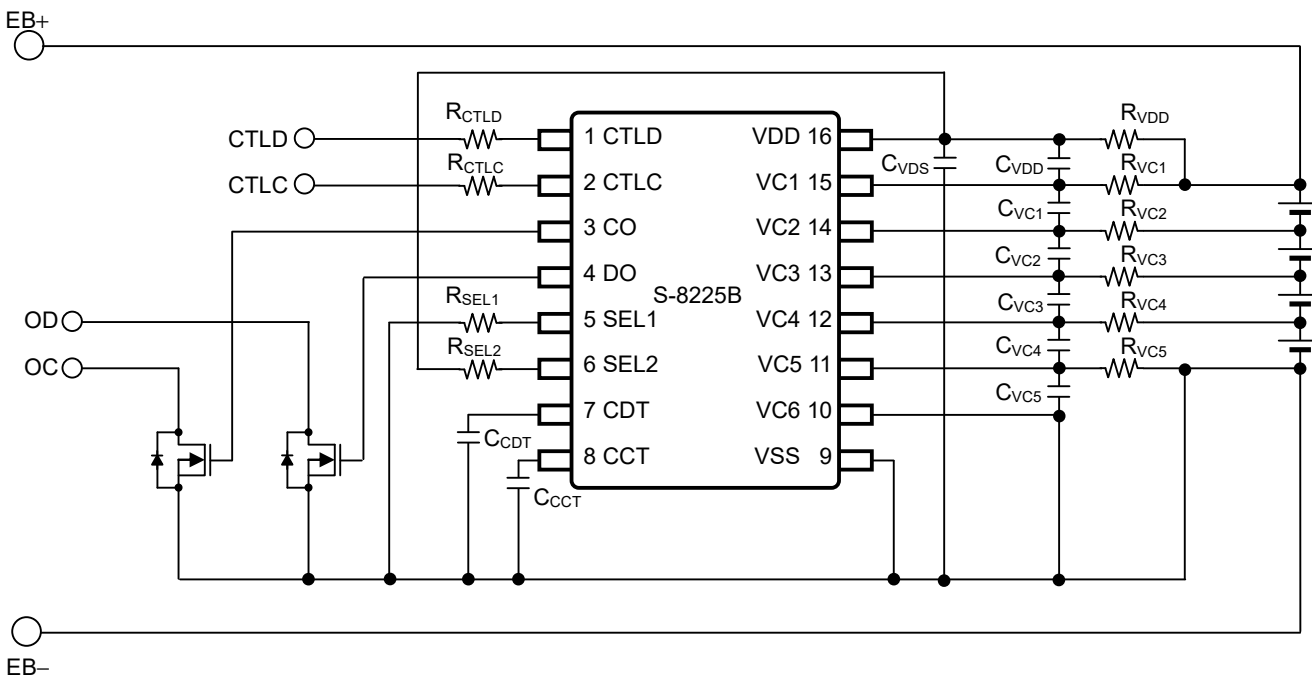

Figure 15

Remark Regarding the recommended values for external components, refer to "Table 9 Constants for External Components".

3. 3-serial cell

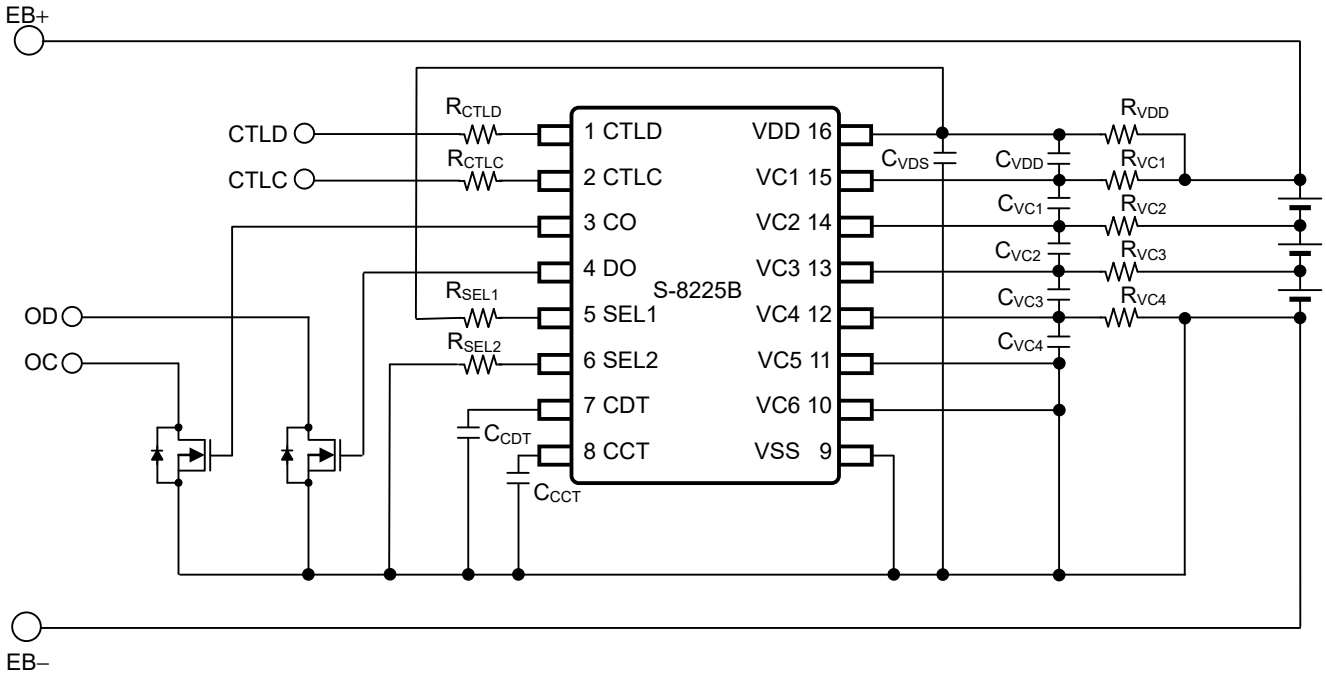

Figure 16

Remark Regarding the recommended values for external components, refer to "Table 9 Constants for External Components".

Table 9 Constants for External Components

Symbol	Min.	Typ.	Max.	Unit
R _{VDD}	50	100	1000	Ω
R _{VCn}	0.5	1	2	kΩ
C _{VDS}	0.01	0.1	1	μF
C _{VDD}	–	0	1	μF
C _{VCn}	0.01	0.1	1	μF
C _{CCT}	0.001	0.1	0.22	μF
C _{CDT}	0.001	0.1	0.22	μF
R _{CTLC} , R _{CTLD}	–	1	–	kΩ
R _{SEL1} , R _{SEL2}	0.5	1	–	kΩ

- Caution**
1. The above constants may be changed without notice.
 2. The example of connection shown above and the constants do not guarantee proper operation. Perform thorough evaluation using the actual application to set the constants.
 3. R_{VC1} to R_{VC6} and C_{VC1} to C_{VC6} should be the same constant, respectively.
 4. Set up R_{VCn} and C_{VCn} as $R_{VCn} \times C_{VCn} \geq 50 \times 10^{-6}$.
 5. Set up R_{VDD} and C_{VDS} as $5 \times 10^{-6} \leq R_{VDD} \times C_{VDS} \leq 100 \times 10^{-6}$.
 6. Set $(R_{VDD} \times C_{VDS}) / (R_{VCn} \times C_{VCn}) = 0.1$.

Remark n = 1 to 6

■ **Precautions**

- The application conditions for the input voltage, output voltage, and load current should not exceed the package power dissipation.
- If both an overcharge battery and an overdischarge battery are included among the whole batteries, the condition is set in overcharge status and overdischarge status. Therefore either charging or discharging is impossible.
- Do not apply an electrostatic discharge to this IC that exceeds the performance ratings of the built-in electrostatic protection circuit.
- ABLIC Inc. claims no responsibility for any disputes arising out of or in connection with any infringement by products including this IC of patents owned by a third party.

■ Characteristics (Typical Data)

1. Detection voltage

1.1 V_{CU} vs. T_a



1.2 V_{CL} vs. T_a

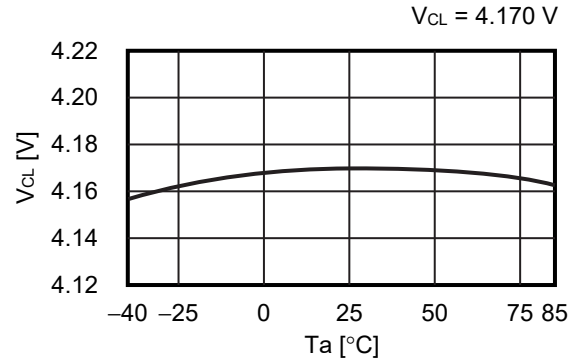

1.3 V_{DL} vs. T_a

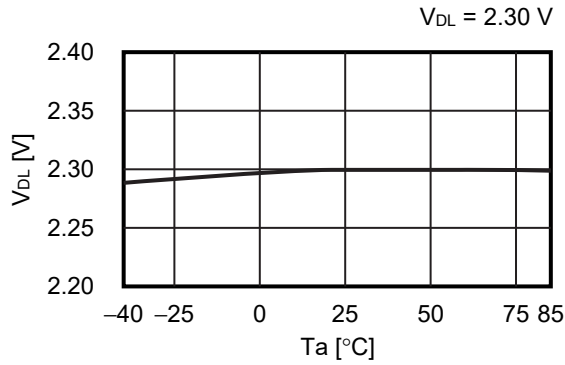

1.4 V_{DU} vs. T_a

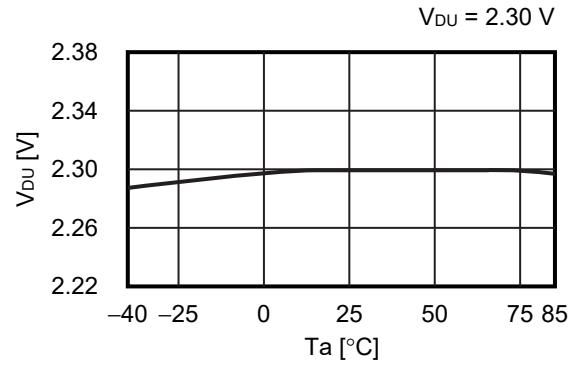

2. Current consumption

2.1 I_{OPE} vs. T_a



2.2 I_{PDN} vs. T_a

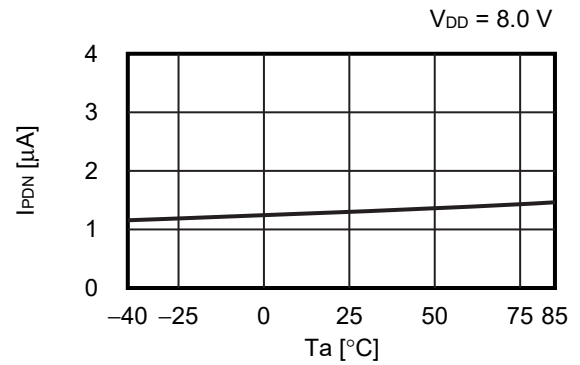

2.3 I_{OPE} vs. V_{DD}



3. Delay time

3.1 t_{CU} vs. T_a



3.2 t_{DL} vs. T_a

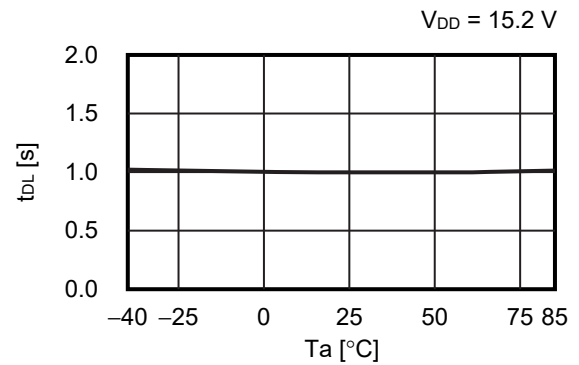

4. Output current

4.1 I_{COL} vs. V_{DD}



4.2 I_{COH} vs. V_{DD}

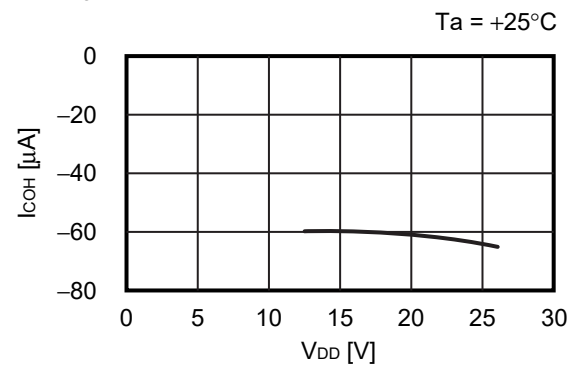

4.3 I_{DOL} vs. V_{DD}

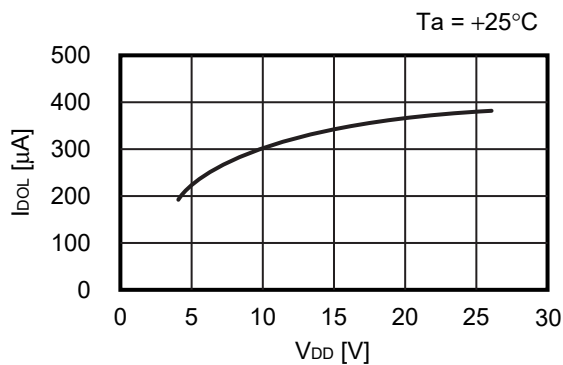

4.4 I_{DOH} vs. V_{DD}

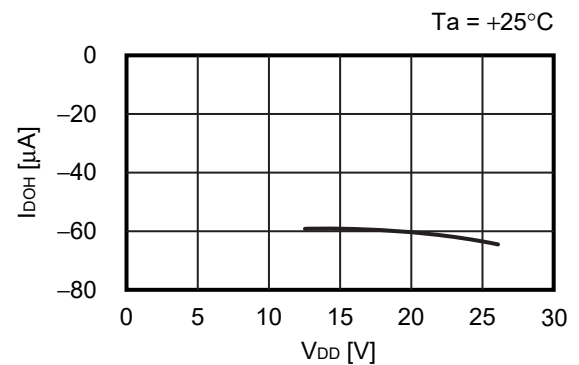

5. Output voltage

5.1 V_{COH} vs. V_{DD}

$T_a = +25^\circ\text{C}$, CO pin output logic active "L", $V_{CU} = 4.220\text{ V}$
 0 V battery detection function "unavailable"

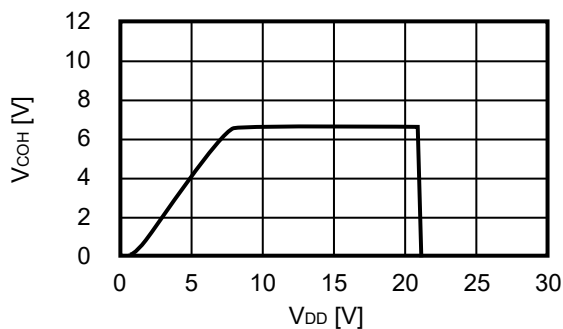

5.2 V_{DOH} vs. V_{DD}

$T_a = +25^\circ\text{C}$, DO pin output logic active "L"
 $V_{DL} = 2.30\text{ V}$

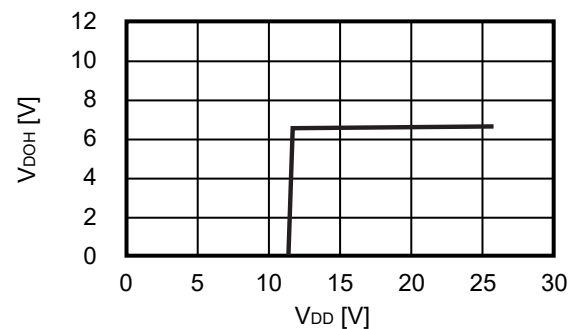



No. FT016-A-P-SD-1.2

TITLE	TSSOP16-A-PKG Dimensions
No.	FT016-A-P-SD-1.2
ANGLE	
UNIT	mm
ABLIC Inc.	



No. FT016-A-C-SD-1.1

TITLE	TSSOP16-A-Carrier Tape
No.	FT016-A-C-SD-1.1
ANGLE	
UNIT	mm
ABLIC Inc.	



Enlarged drawing in the central part

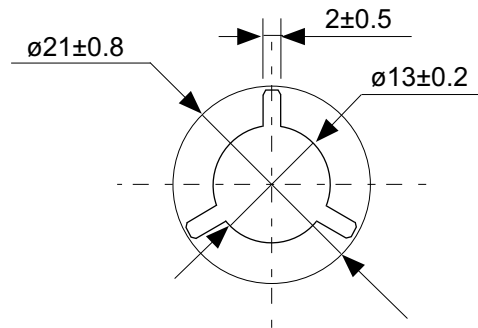

No. FT016-A-R-S1-1.0

TITLE	TSSOP16-A- Reel		
No.	FT016-A-R-S1-1.0		
ANGLE		QTY.	4,000
UNIT	mm		
ABLIC Inc.			

Disclaimers (Handling Precautions)

1. All the information described herein (product data, specifications, figures, tables, programs, algorithms and application circuit examples, etc.) is current as of publishing date of this document and is subject to change without notice.
2. The circuit examples and the usages described herein are for reference only, and do not guarantee the success of any specific mass-production design.
ABLIC Inc. is not liable for any losses, damages, claims or demands caused by the reasons other than the products described herein (hereinafter "the products") or infringement of third-party intellectual property right and any other right due to the use of the information described herein.
3. ABLIC Inc. is not liable for any losses, damages, claims or demands caused by the incorrect information described herein.
4. Be careful to use the products within their ranges described herein. Pay special attention for use to the absolute maximum ratings, operation voltage range and electrical characteristics, etc.
ABLIC Inc. is not liable for any losses, damages, claims or demands caused by failures and / or accidents, etc. due to the use of the products outside their specified ranges.
5. Before using the products, confirm their applications, and the laws and regulations of the region or country where they are used and verify suitability, safety and other factors for the intended use.
6. When exporting the products, comply with the Foreign Exchange and Foreign Trade Act and all other export-related laws, and follow the required procedures.
7. The products are strictly prohibited from using, providing or exporting for the purposes of the development of weapons of mass destruction or military use. ABLIC Inc. is not liable for any losses, damages, claims or demands caused by any provision or export to the person or entity who intends to develop, manufacture, use or store nuclear, biological or chemical weapons or missiles, or use any other military purposes.
8. The products are not designed to be used as part of any device or equipment that may affect the human body, human life, or assets (such as medical equipment, disaster prevention systems, security systems, combustion control systems, infrastructure control systems, vehicle equipment, traffic systems, in-vehicle equipment, aviation equipment, aerospace equipment, and nuclear-related equipment), excluding when specified for in-vehicle use or other uses by ABLIC, Inc. Do not apply the products to the above listed devices and equipments.
ABLIC Inc. is not liable for any losses, damages, claims or demands caused by unauthorized or unspecified use of the products.
9. In general, semiconductor products may fail or malfunction with some probability. The user of the products should therefore take responsibility to give thorough consideration to safety design including redundancy, fire spread prevention measures, and malfunction prevention to prevent accidents causing injury or death, fires and social damage, etc. that may ensue from the products' failure or malfunction.
The entire system in which the products are used must be sufficiently evaluated and judged whether the products are allowed to apply for the system on customer's own responsibility.
10. The products are not designed to be radiation-proof. The necessary radiation measures should be taken in the product design by the customer depending on the intended use.
11. The products do not affect human health under normal use. However, they contain chemical substances and heavy metals and should therefore not be put in the mouth. The fracture surfaces of wafers and chips may be sharp. Be careful when handling these with the bare hands to prevent injuries, etc.
12. When disposing of the products, comply with the laws and ordinances of the country or region where they are used.
13. The information described herein contains copyright information and know-how of ABLIC Inc. The information described herein does not convey any license under any intellectual property rights or any other rights belonging to ABLIC Inc. or a third party. Reproduction or copying of the information from this document or any part of this document described herein for the purpose of disclosing it to a third-party is strictly prohibited without the express permission of ABLIC Inc.
14. For more details on the information described herein or any other questions, please contact ABLIC Inc.'s sales representative.
15. This Disclaimers have been delivered in a text using the Japanese language, which text, despite any translations into the English language and the Chinese language, shall be controlling.

2.4-2019.07