



ACE5290B

20V Complementary Enhancement Mode Field Effect Transistor

Description

The ACE5290B combines advanced trench MOSFET technology with a low resistance package to provide extremely low $R_{DS(ON)}$. This device is ideal for load switch and battery protection applications.

Features

N-channel

- V_{DS} (V) = 20V
- $I_D=3.5A$
- $R_{DS(ON)}$
 $< 50m\Omega$ (VGS=4.5V)
 $< 80m\Omega$ (VGS=2.5V)

P-channel

- V_{DS} (V) = -20V
- $I_D = -2.5A$
- $R_{DS(ON)}$
 $< 85m\Omega$ (VGS = -4.5V)
 $< 115m\Omega$ (VGS = -2.5V)

Absolute Maximum Ratings

Parameter		Symbol	N-channel	P-channel	Unit
Drain-Source Voltage		V_{DSS}	20	-20	V
Gate-Source Voltage		V_{GSS}	± 12	± 12	V
Drain Current (Continuous)*AC	$T_A=25^\circ C$	I_D	3.5	-2.5	A
	$T_A=70^\circ C$		3	-2	
Drain Current (Pulsed)*B		I_{DM}	13	-13	A
Power Dissipation	$T_A=25^\circ C$	P_D	1.1	1.1	W
	$T_A=70^\circ C$		0.7	0.7	
Operating temperature / storage temperature		T_J/T_{STG}	-55~150	-55~150	$^\circ C$

A: The value of $R_{\theta JA}$ is measured with the device mounted on 1in² FR-4 board with 2oz. Copper, in a still air environment with $T_A=25^\circ C$. The value in any given application depends on the user's specific board design.

B: Repetitive rating, pulse width limited by junction temperature.

C: The current rating is based on the $\leq 10s$ junction to ambient thermal resistance rating.



ACE5290B

20V Complementary Enhancement Mode Field Effect Transistor

Packaging Type

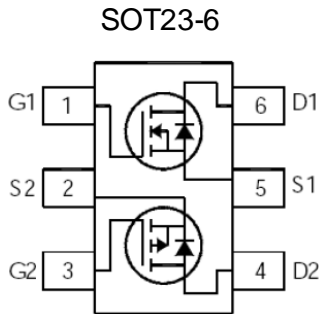

Ordering information

ACE5290B XX + H

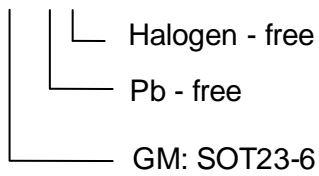



ACE5290B

20V Complementary Enhancement Mode Field Effect Transistor

N-channel Electrical Characteristics $T_A=25^\circ\text{C}$, unless otherwise specified.

Parameter	Symbol	Test Conditions	Min	Typ	Max	Unit
Static						
Drain-Source Breakdown Voltage	$V_{(BR)DSS}$	$V_{GS} = 0V, I_D = 250\mu A$	20			V
Zero Gate Voltage Drain Current	I_{DSS}	$V_{DS} = 20V, V_{GS} = 0V$			1	μA
Gate Threshold Voltage	$V_{GS(TH)}$	$V_{GS} = V_{DS}, I_{DS} = 250\mu A$	0.6		1.0	V
Gate Leakage Current	I_{GSS}	$V_{GS} = \pm 12V, V_{DS} = 0V$			± 100	nA
Drain-Source On-state Resistance	$R_{DS(on)}$	$V_{GS} = 4.5V, I_D = 3.5A$		36	50	m Ω
		$V_{GS} = 2.5V, I_D = 2.5A$		46	80	
		$V_{GS} = 1.8V, I_D = 2A$		85	110	
Forward Trans Conductance	g_{FS}	$V_{DS} = 5V, I_D = 3A$		16		S
Diode Forward Voltage	V_{SD}	$I_{SD} = 1.7A, V_{GS} = 0V$		0.74	1.0	V
Maximum Body-Diode Continuous Current	I_S				1.7	A
Switching						
Total Gate Charge	Q_g	$V_{DS} = 4.5V, I_D = 10A,$ $V_{GS} = 4V$		2.4		nC
Gate-Source Charge	Q_{gs}			0.3		nC
Gate-Drain Charge	Q_{gd}			0.8		nC
Turn-on Delay Time	$t_{d(on)}$	$V_{DD} = 10V, I_D = 1A,$ $V_{GS} = 4.5V, R_{GEN} = 6\Omega$		2.1		ns
Turn-on Rise Time	t_r			3.6		ns
Turn-off Delay Time	$t_{d(off)}$			23.3		ns
Turn-off Fall Time	t_f			4.5		ns
Dynamic						
Input Capacitance	C_{iss}	$V_{DS} = 8V, V_{GS} = 0V,$ $f = 1.0MHz$		240.3		pF
Output Capacitance	C_{oss}			40		pF
Reverse Transfer Capacitance	C_{rss}			22		pF

- A. The value of $R_{\theta JA}$ is measured with the device mounted on 1in² FR-4 board with 2oz. Copper, in a still air environment with $T_A=25^\circ\text{C}$. The value in any given application depends on the user's specific board design.
- B. Repetitive rating, pulse width limited by junction temperature.
- C. The current rating is based on the $t \leq 10s$ junction to ambient thermal resistance rating.



ACE5290B 20V Complementary Enhancement Mode Field Effect Transistor

N-channel Typical Electrical And Thermal Characteristics

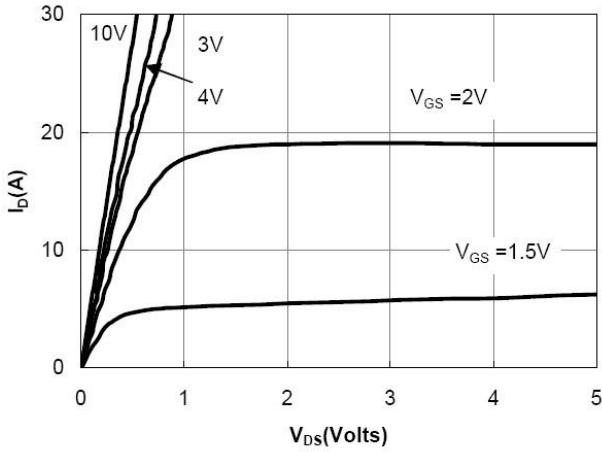

Figure 1: On-Regions Characteristics

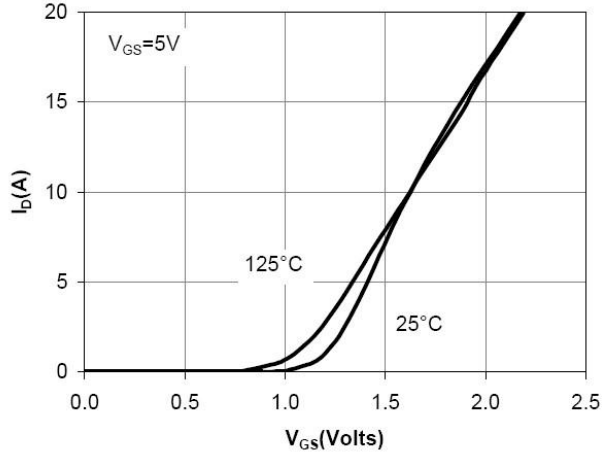

Figure 2: Transfer Characteristics

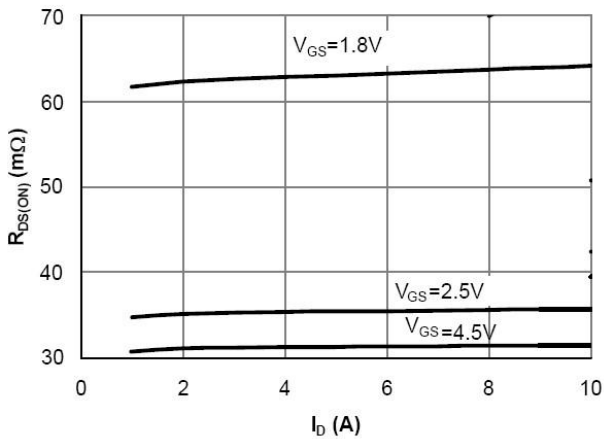

Figure 3: On-Resistance vs. Drain Current and Gate Voltage

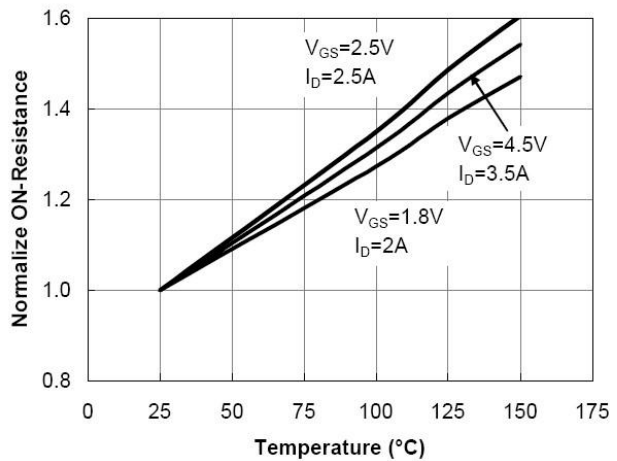

Figure 4: On-Resistance vs. Junction Temperature

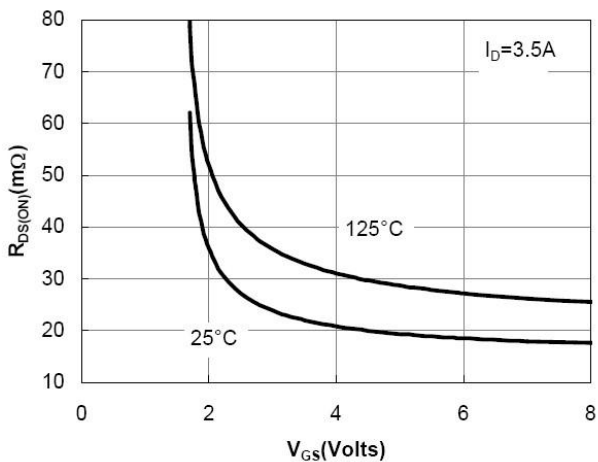

Figure 5: On-Resistance vs. Gate-Source Voltage

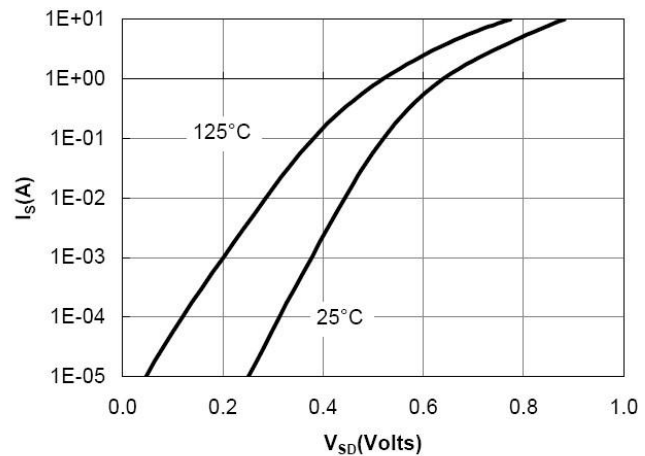

Figure 6: Body-Diode Characteristics



ACE5290B 20V Complementary Enhancement Mode Field Effect Transistor

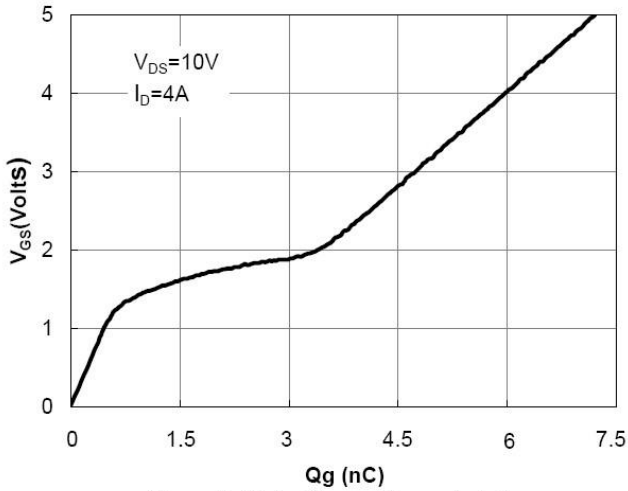

Figure 7: Gate-Charge Characteristics

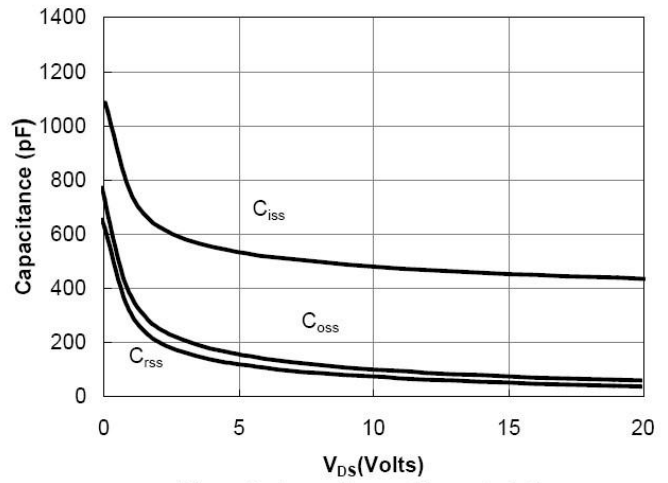

Figure 8: Capacitance Characteristics

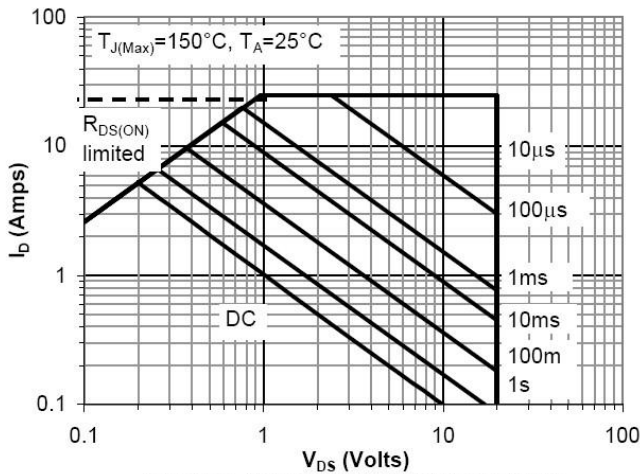

Figure 9: Maximum Forward Biased Safe Operating Area

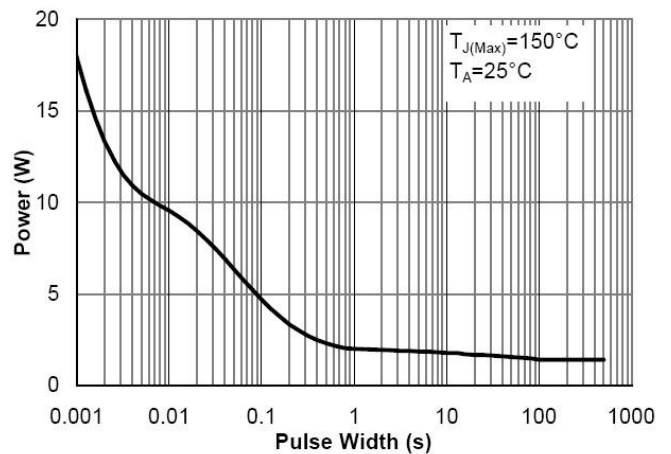

Figure 10: Single Pulse Power Rating Junction-to-Ambient

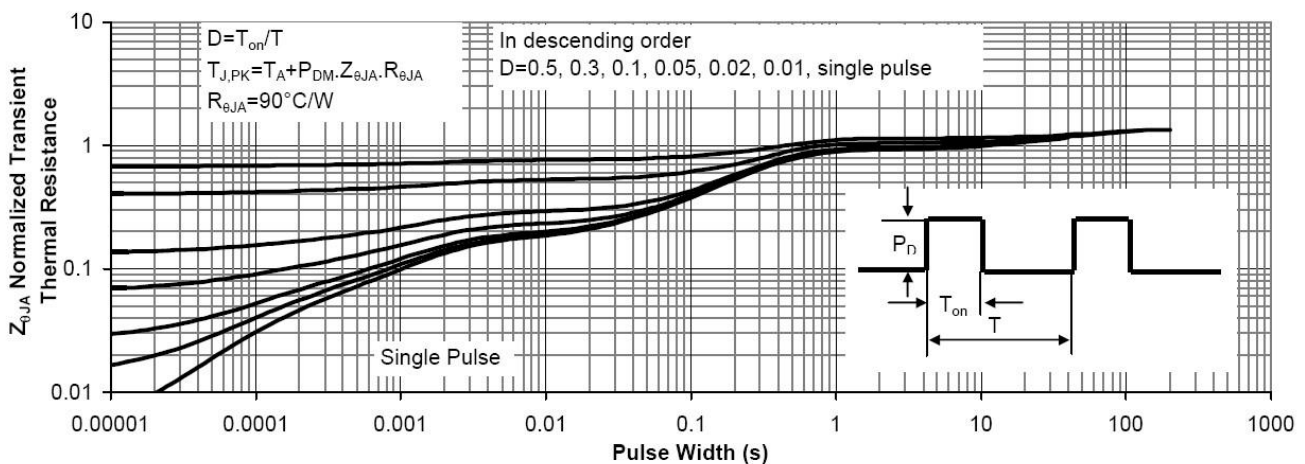

Figure 11: Normalized Maximum Transient Thermal Impedance



ACE5290B

20V Complementary Enhancement Mode Field Effect Transistor

P-channel Electrical Characteristics $T_A=25^\circ\text{C}$, unless otherwise specified.

Parameter	Symbol	Test Conditions	Min	Typ	Max	Unit
Static						
Drain-Source Breakdown Voltage	$V_{(BR)DSS}$	$V_{GS} = 0V, I_D = -250\mu A$	-20			V
Zero Gate Voltage Drain Current	I_{DSS}	$V_{DS} = -20V, V_{GS} = 0V$			-1	μA
Gate Threshold Voltage	$V_{GS(TH)}$	$V_{GS} = V_{DS}, I_{DS} = -250\mu A$	-0.5		-1	V
Gate Leakage Current	I_{GSS}	$V_{GS} = \pm 12V, V_{DS} = 0V$			± 100	nA
Drain-Source On-state Resistance	$R_{DS(on)}$	$V_{GS} = -4.5V, I_D = -2.8A$		77	85	m Ω
		$V_{GS} = -2.5V, I_D = -2A$		92	115	
		$V_{GS} = -1.8V, I_D = -2A$		118	200	
Forward Trans Conductance	g_{FS}	$V_{DS} = -5V, I_D = -2.5A$		13		S
Diode Forward Voltage	V_{SD}	$I_{SD} = -1.6A, V_{GS} = 0V$		-0.18	-1.0	V
Maximum Body-Diode Continuous Current	I_S				-1.6	A
Switching						
Total Gate Charge	Q_g	$V_{DS} = -6V, I_D = -2.8A,$ $V_{GS} = -4.5V$		6.6	8.6	nC
Gate-Source Charge	Q_{gs}			0.3	0.4	nC
Gate-Drain Charge	Q_{gd}			1.3	1.7	nC
Turn-on Delay Time	$t_{d(on)}$	$V_{DD} = -6V, R_L = 6\Omega,$ $I_D = -1A, V_{GS} = -4.5V,$ $R_{GEN} = 6\Omega$		9.7	19.4	ns
Turn-on Rise Time	t_r			3.6	7.1	ns
Turn-off Delay Time	$t_{d(off)}$			70.6	141.2	ns
Turn-off Fall Time	t_f			7.8	15.6	ns
Dynamic						
Input Capacitance	C_{iss}	$V_{DS} = -6V, V_{GS} = 0V,$ $f = 1.0MHz$		589		pF
Output Capacitance	C_{oss}			91.2		pF
Reverse Transfer Capacitance	C_{rss}			67.2		pF

- A. The value of $R_{\theta JA}$ is measured with the device mounted on 1in² FR-4 board with 2oz. Copper, in a still air environment with $T_A=25^\circ\text{C}$. The value in any given application depends on the user's specific board design.
- B. Repetitive rating, pulse width limited by junction temperature.
- C. The current rating is based on the $t \leq 10s$ junction to ambient thermal resistance rating.



ACE5290B 20V Complementary Enhancement Mode Field Effect Transistor

P-channel Typical Electrical And Thermal Characteristics

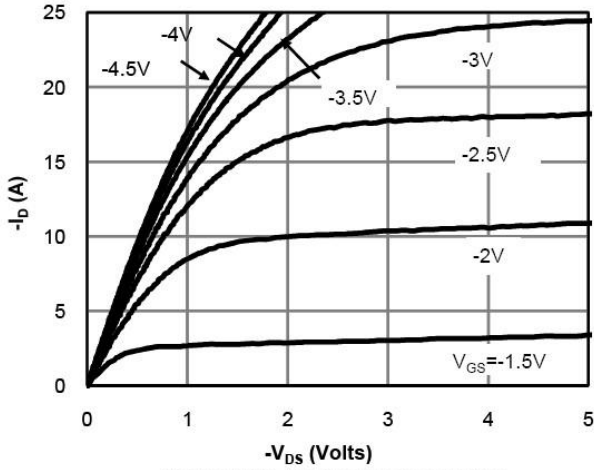

Figure 1: On-Region Characteristics

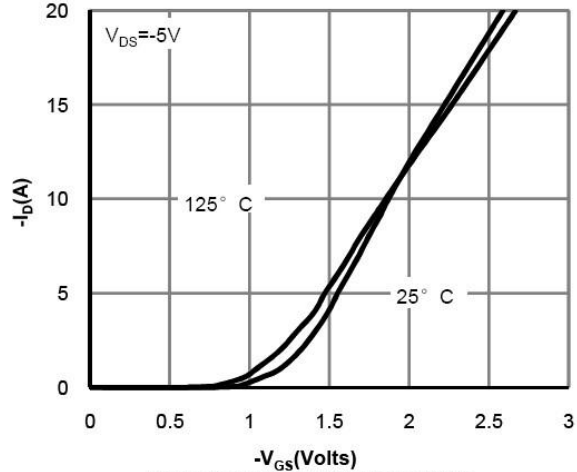

Figure 2: Transfer Characteristics

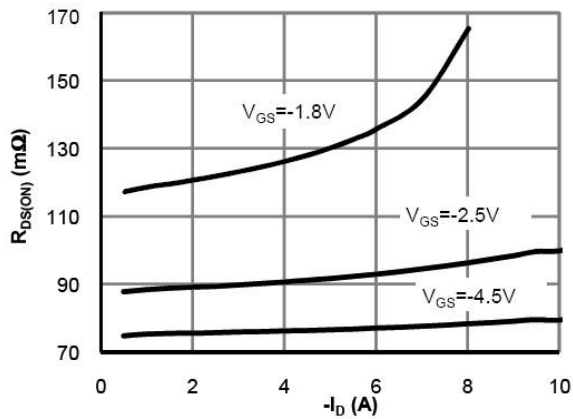

Figure 3: On-Resistance vs. Drain Current and Gate Voltage

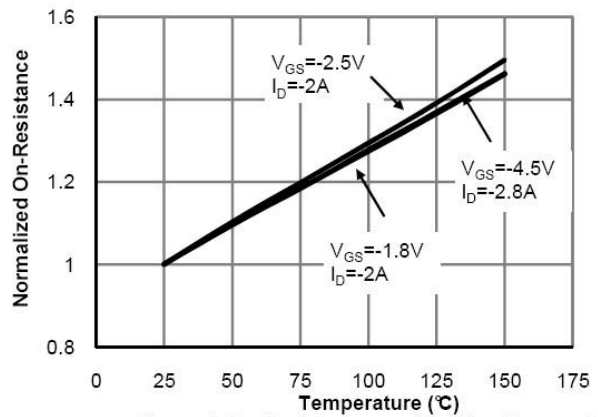

Figure 4: On-Resistance vs. Junction Temperature

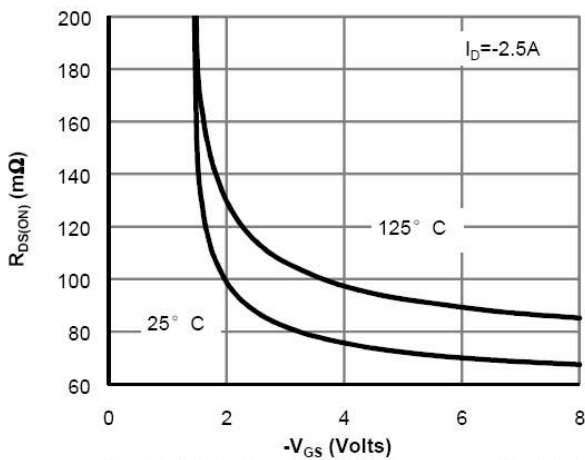

Figure 5: On-Resistance vs. Gate-Source Voltage

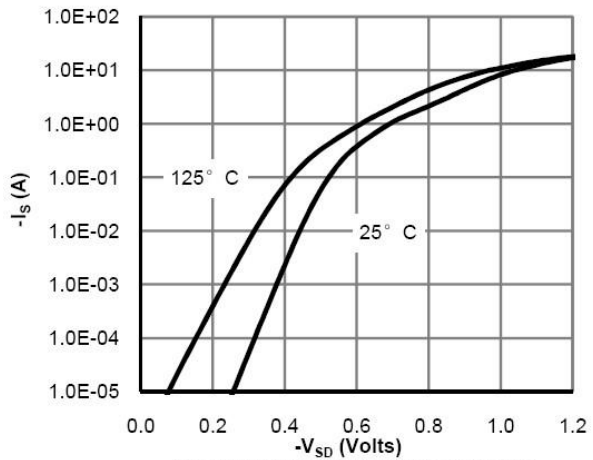

Figure 6: Body-Diode Characteristics



ACE5290B

20V Complementary Enhancement Mode Field Effect Transistor

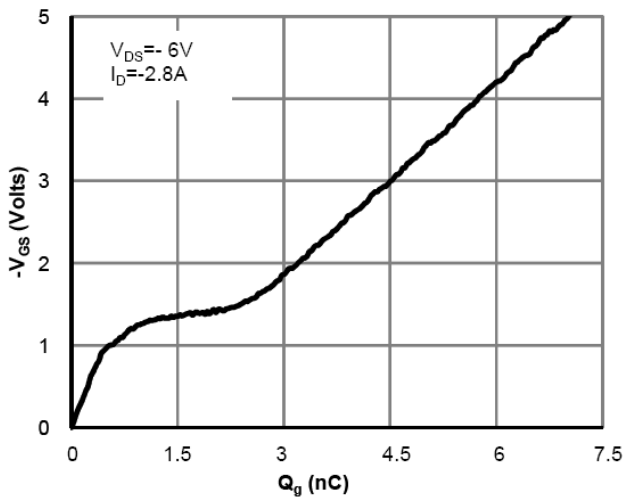

Figure 7: Gate-Charge Characteristics

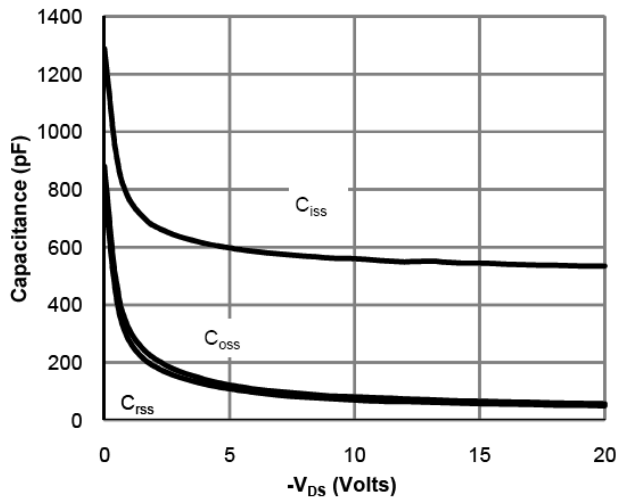

Figure 8: Capacitance Characteristics

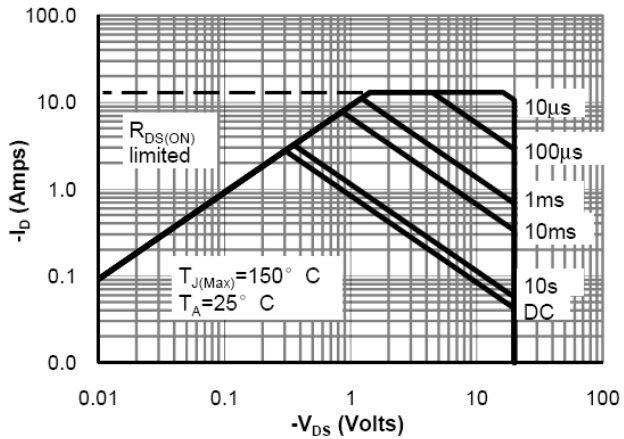

Figure 9: Maximum Forward Biased Safe Operating Area

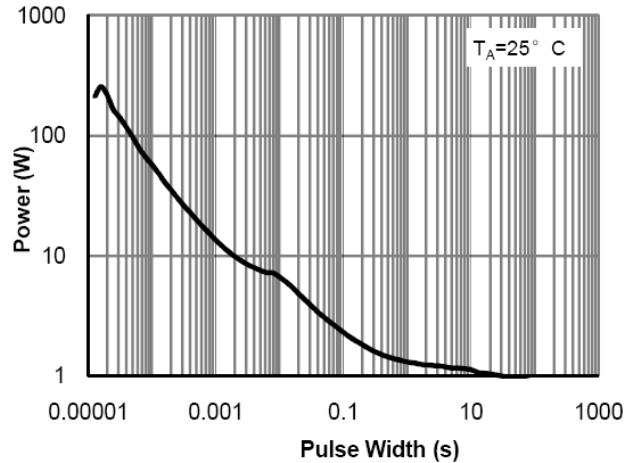

Figure 10: Single Pulse Power Rating Junction-to-Ambient

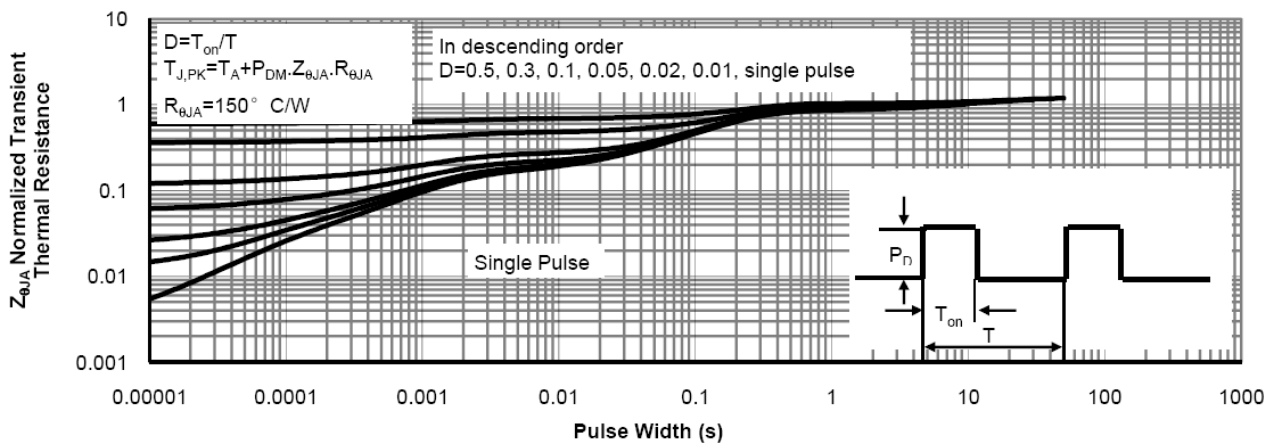

Figure 11: Normalized Maximum Transient Thermal Impedance



ACE5290B

20V Complementary Enhancement Mode Field Effect Transistor

Packing Information

SOT23-6

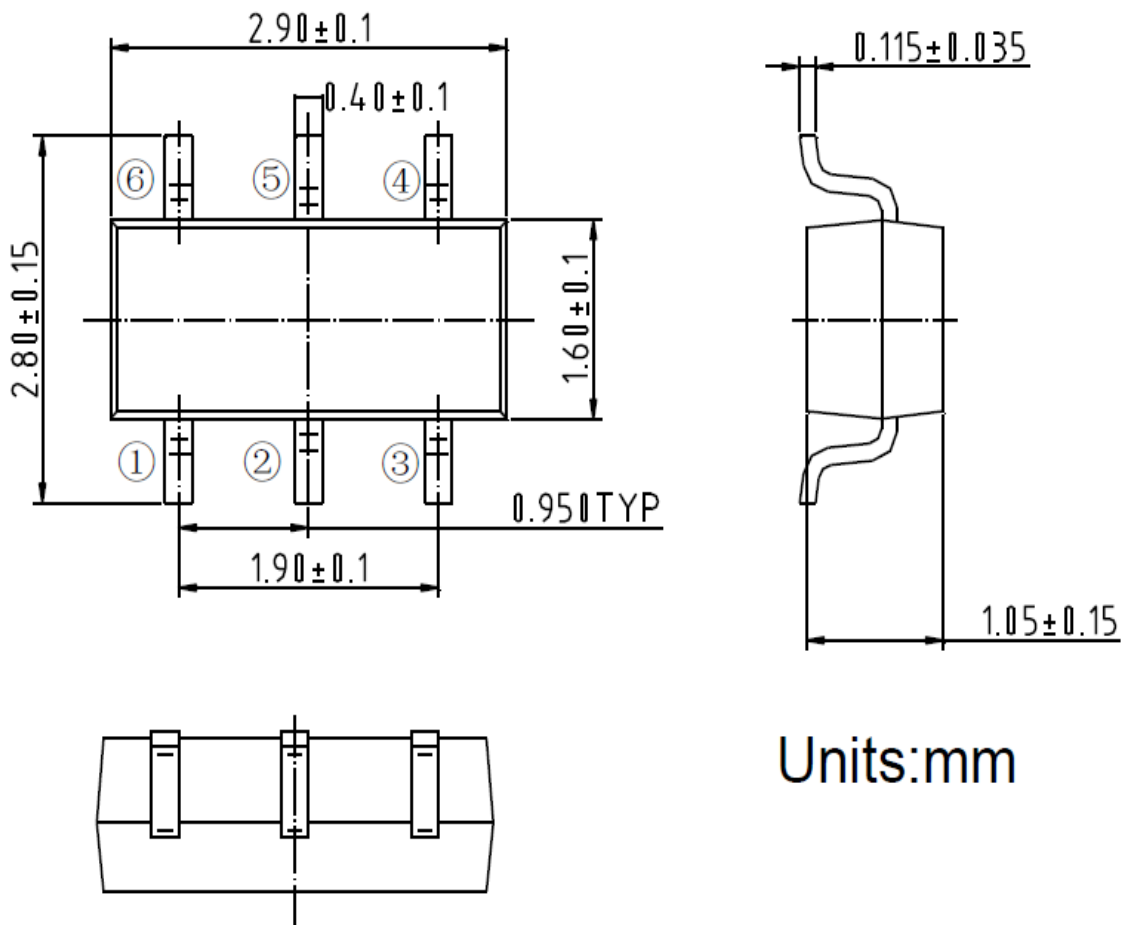



ACE5290B

20V Complementary Enhancement Mode Field Effect Transistor

Notes

ACE does not assume any responsibility for use as critical components in life support devices or systems without the express written approval of the president and general counsel of ACE Electronics Co., LTD. As used herein:

1. Life support devices or systems are devices or systems which, (a) are intended for surgical implant into the body, or (b) support or sustain life, and whose failure to perform when properly used in accordance with instructions for use provided in the labeling, can be reasonably expected to result in a significant injury to the user.
2. A critical component is any component of a life support device or system whose failure to perform can be reasonably expected to cause the failure of the life support device or system, or to affect its safety or effectiveness.

ACE Technology Co., LTD.
<http://www.ace-ele.com/>